

PRESOTTO

**DIVANO KOS/
KOS SOFA**
design: **Presotto Studio**



INFORMAZIONI TECNICHE

Le sedute della collezione Kos possono essere utilizzate in varie configurazioni, gli elementi sono fissati fra di loro nella parte inferiore con delle pinze metalliche per garantire la stabilità.

**CARATTERISTICHE
POLTRONE E DIVANI:**
sfoderabili in tessuto e fissi in pelle.

STRUTTURA SEDUTA:
legno di abete e multistrato di pioppo con sistema di molleggio su cinghie elastiche.

STRUTTURA SCHIENA E BRACCIOLO:
legno di abete e multistrato di pioppo.

IMBOTTITURA SCHIENA E BRACCIOLO:
poliuretano espanso a quote differenziate (PF 65 FR + PF 50 FR) rivestito con vellutino resinato 250 gr in fibra di poliestere.

PIEDINI:
antiscivolo.

FINITURE
Tessuti disponibili in cat. B,F,G,L,M
Pelle, Pelle Extra e Pelle Super.
Piedini verniciati nero.

TECHNICAL INFO

Kos collection seats can be used in various configurations, the elements are fixed to each other in lower part with metal clips ensure stability.

**CHARACTERISTIC
ARMCHAIRS AND SOFAS:**
removable cover fabric and fixed in leather.

SEAT STRUCTURE:
fir wood and poplar plywood with elastic belts.

BACK AND ARMREST STRUCTURE:
fir wood and poplar plywood.

**SEAT STRUCTURE AND ARMREST
PADDING:**
polyurethane foam in different densities (PF 65 FR + PF 50 FR) covered with 250 gr resin coated interliner in polyester fiber.

FEET:
non-slip.

FINISHES
Fabrics available in cat. B,F,G,L,M
Leather, Extra Leather and Super Leather.
Black painted feet.

P

PRESOTTO

SEDUTE /SEATS

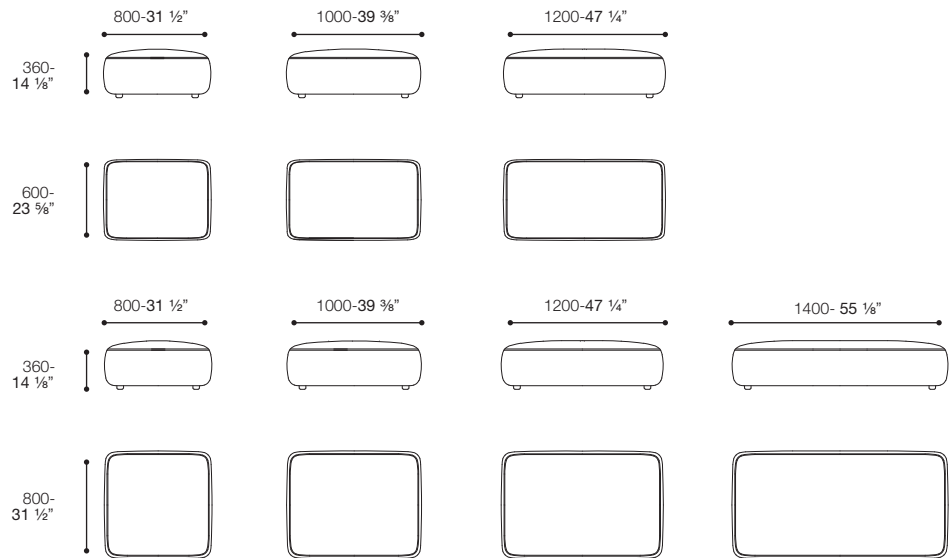

SCHIENALI /BACKREST

P

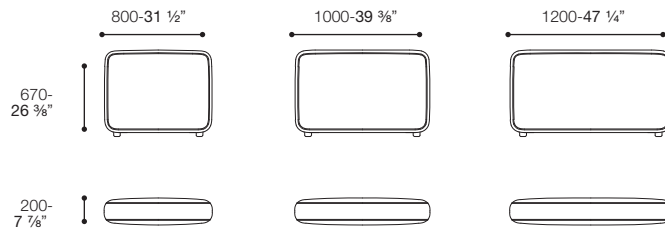

BRACCIOLI /ARMRESTS

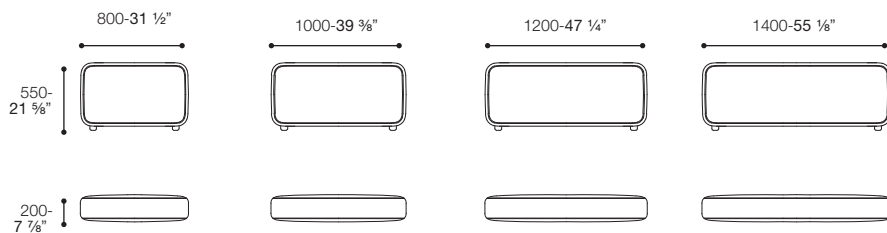

CUSCINI SCHIENALI (gomma+ piuma) /BACK CUSHIONS (foam+feather)

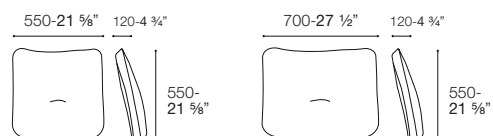

CUSCINI ORNAMENTALI (solo piuma) /ORNAMENTAL CUSHIONS (feather only)

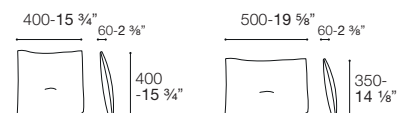

PRESOTTO

MODULARITÀ /MODULARITY

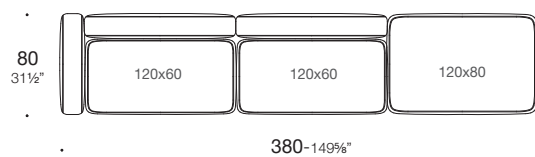
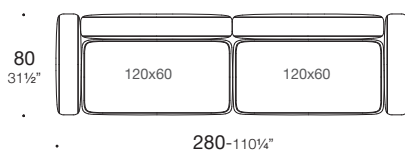
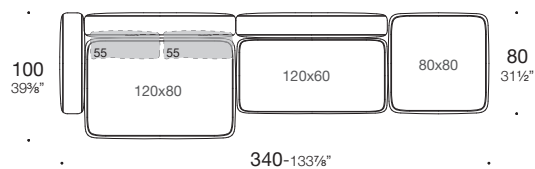
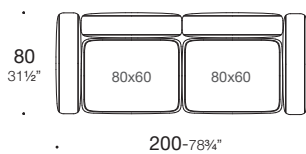

P

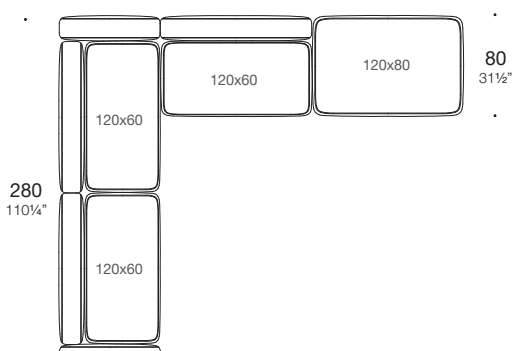
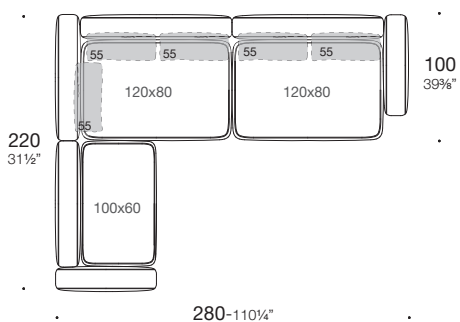
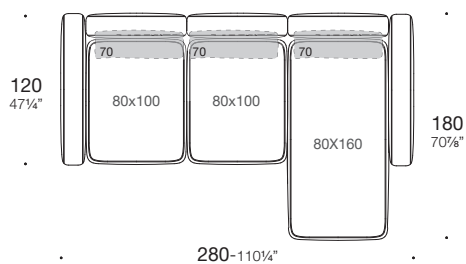
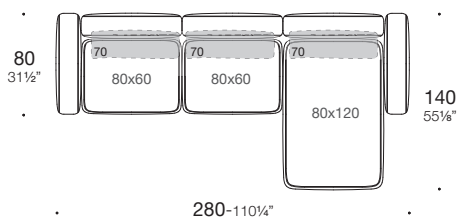

PRESOTTO

ESEMPI DI COMPOSIZIONI /COMPOSITION EXAMPLES

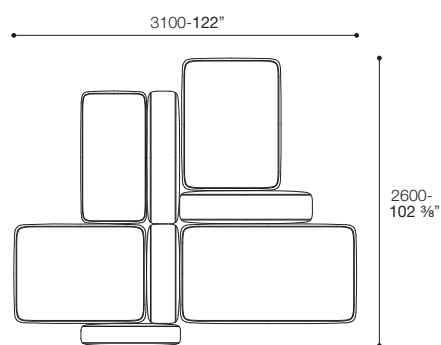
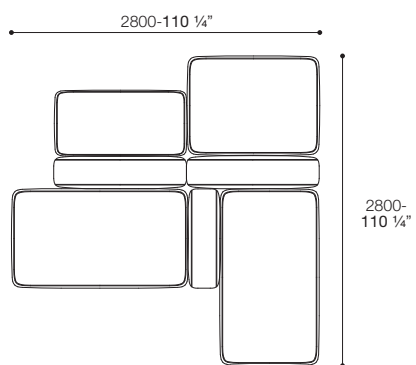
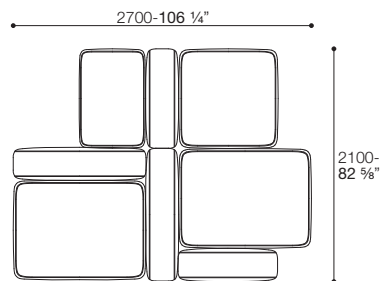
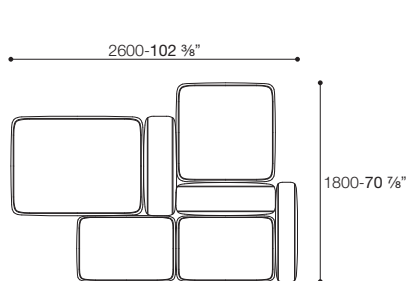

P

