

# MATERIA TV UNITS

1048D

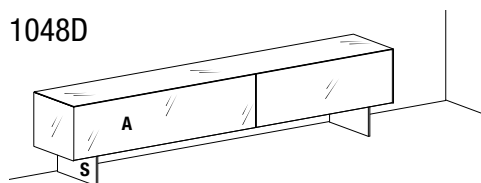

**Indicare:**

A- colore frontale e struttura;  
S- finitura sostegni: vetro: extra-chiaro o fumè grigio,  
metallo: Peltro steel o Titanio steel.

**Optional:** passacavi, ripetitore IR, 1-2 pannelli  
bifacciali, illuminazione LED interna, illuminazione LED  
sottobase.

Apertura push-pull.

**Please specify:**

A- front and structure colour;  
S- support finish: glass: extra-clear or smoked grey,  
metal: Peltro Steel or Titanio Steel.

**Optionals:** cableway, IR repeater, 1-2 double-faced  
panels, internal LED lighting, LED lighting under base.  
Push-pull opening.

Versione destra, disponibile anche sinistra.  
Right-hand version, also available as left-hand version.

Descrizione/Description	L/W	P/D	A/H	Codice Code	Vetro lucido Polished glass	Vetro opaco Matt glass	XGlass*
<p>148 40,6 H</p>	148	40,6	38,9	MTU204			
			48,1	MTU205			
			57,3	MTU206			
<p>148 40,6 H 73,6 73,6</p>	148	40,6	57,3	MTU231			
<p>184,8 40,6 H</p>	184,8	40,6	38,9	MTU210			
			48,1	MTU211			
			57,3	MTU212			
<p>184,8 40,6 H 92 92</p>	184,8	40,6	38,9	MTU213			
			48,1	MTU214			
			57,3	MTU215			
<p>184,8 40,6 H 92 92</p>	184,8	40,6	57,3	MTU232			
<p>221,6 40,6 H</p>	221,6	40,6	38,9	MTU216			
			48,1	MTU217			
			57,3	MTU218			
<p>221,6 40,6 H 110,4 110,4</p>	221,6	40,6	38,9	MTU219			
			48,1	MTU220			
			57,3	MTU221			
<p>221,6 40,6 H 110,4 110,4</p>	221,6	40,6	57,3	MTU233			
<p>258,4 40,6 H 147,2 110,4</p>	258,4	40,6	38,9	MTU222			
			48,1	MTU223			
			57,3	MTU224			
<p>258,4 40,6 H 147,2 110,4</p>	258,4	40,6	57,3	MTU234			
<p>276,8 40,6 H 184 92</p>	276,8	40,6	38,9	MTU236			
			48,1	MTU237			
			57,3	MTU238			
<p>295,2 40,6 H 184 110,4</p>	295,2	40,6	38,9	MTU225			
			48,1	MTU226			
			57,3	MTU227			
<p>295,2 40,6 H 184 110,4</p>	295,2	40,6	57,3	MTU235			
<p>332 40,6 H 184 73,6 73,6</p>	332	40,6	38,9	MTU228			
			48,1	MTU229			
			57,3	MTU230			

# MATERIA TV UNITS

1048C

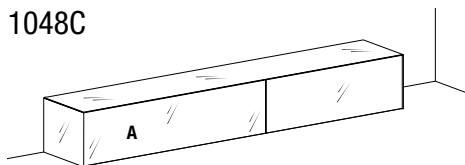

**Indicare:**

A- colore frontale e struttura.

**Optional:** passacavi, ripetitore IR, 1-2 pannelli bifacciali, illuminazione LED interna.

Apertura push-pull.

**Please specify:**

A- front and structure colour.

**Optionals:** cableway, IR repeater, 1-2 double-faced panels, internal LED lighting.

Push-pull opening.

Versione destra, disponibile anche sinistra.

Right-hand version, also available as left-hand version.

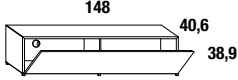
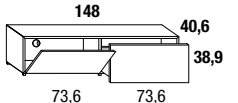
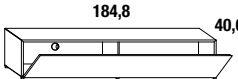
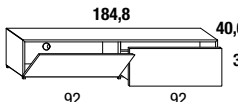
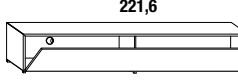
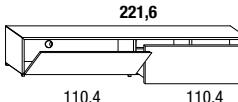
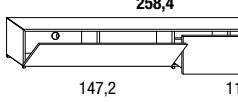
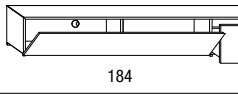
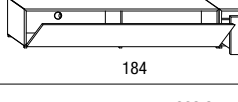
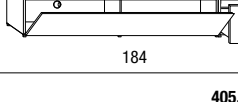
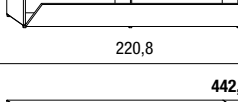
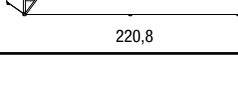
Descrizione/Description	L//W	P//D	A//H	Codice Code	Vetro lucido Polished glass	Vetro opaco Matt glass	XGlass*
	148	40,6	38,9	MTU102			
	148	40,6	38,9	MTU103			
	184,8	40,6	38,9	MTU104			
	184,8	40,6	38,9	MTU105			
	221,6	40,6	38,9	MTU106			
	221,6	40,6	38,9	MTU107			
	258,4	40,6	38,9	MTU108			
	295,2	40,6	38,9	MTU109			
	332	40,6	38,9	MTU110			
	368,8	40,6	38,9	MTU111			
	405,6	40,6	38,9	MTU112			
	442,4	40,6	38,9	MTU113			

\*XGlass disponibile nelle finiture lucido o opaco.

\*XGlass available in polished or matt finishes.

# MATERIA TV UNITS

1476

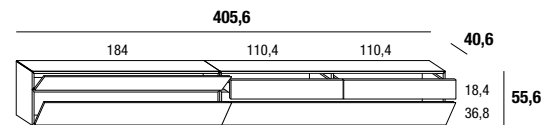
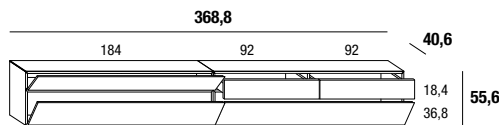
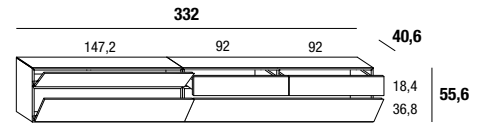
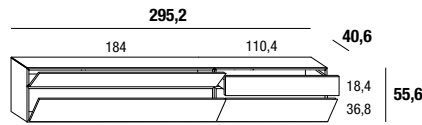
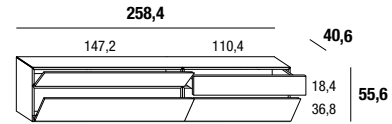
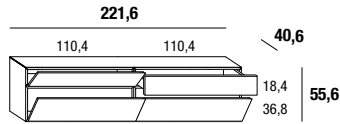
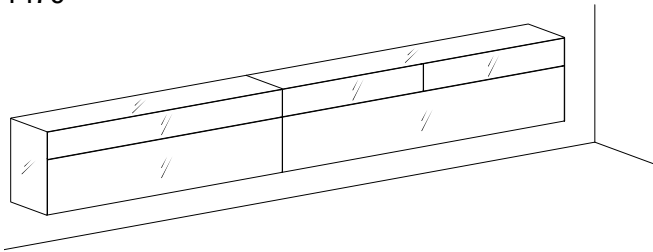

**Indicare** un unico colore per struttura e frontali.

**Optional:** passacavi, ripetitore IR, illuminazione LED interna, illuminazione LED sottobase.

**Specify** one colour for structure and fronts.

**Optionals:** cableway, IR repeater, internal LED lighting, LED lighting under base.

Larghezza Width	Profondità Depth	Altezza Height	Codice Code	Vetro lucido Polished glass	Vetro opaco Matt glass	XGlass lucido o opaco Polished or matt XGlass
221,6	40,6	55,6	147601			
258,4	40,6	55,6	147602			
295,2	40,6	55,6	147603			
332	40,6	55,6	147604			
368,8	40,6	55,6	147605			
405,6	40,6	55,6	147606			

1479

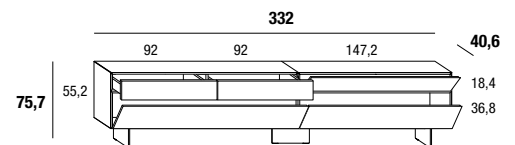
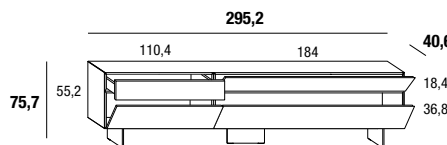
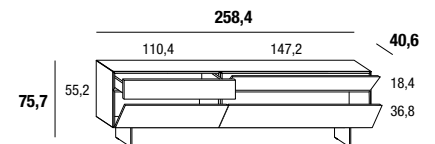
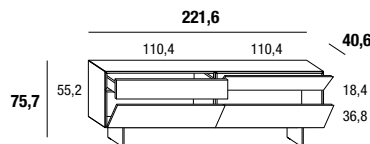
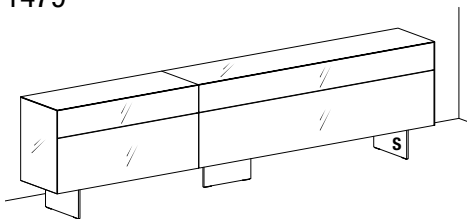

**Indicare** un unico colore per struttura e frontali.

S- finitura sostegni: vetro: extra-chiaro, fumè grigio, metallo: Peltro steel o Titanio steel.

**Optional:** passacavi, ripetitore IR, illuminazione LED interna, illuminazione LED sottobase.

**Specify** one colour for structure and fronts.

S- support finish: glass: extra-clear, smoked grey, metal: Peltro Steel or Titanio Steel.

**Optionals:** cableway, IR repeater, internal LED lighting, LED lighting under base.

Larghezza Width	Profondità Depth	Altezza Height	Codice Code	Vetro lucido Polished glass	Vetro opaco Matt glass	XGlass lucido o opaco Polished or matt XGlass
221,6	40,6	75,7	147901			
258,4	40,6	75,7	147902			
295,2	40,6	75,7	147903			
332	40,6	75,7	147904			

2153

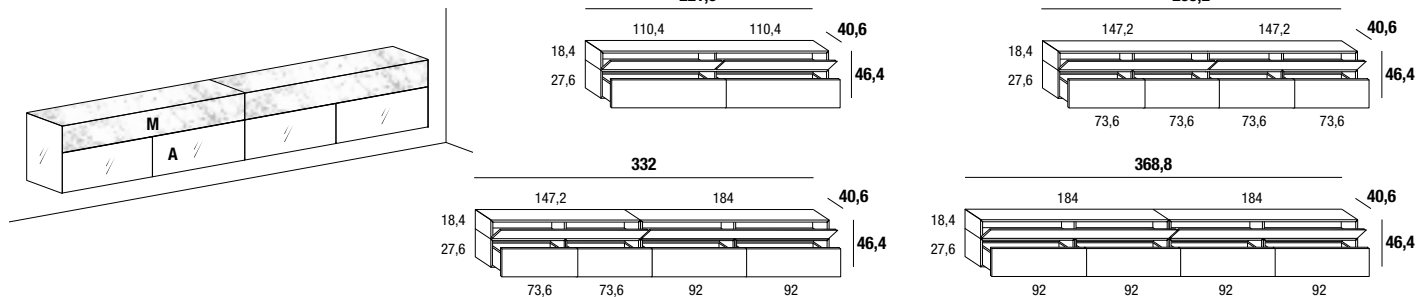

**Indicare:**

A- colore frontale;  
M- colore frontale e top XGlass.  
Apertura push-pull.

**Optional:** passacavi, ripetitore IR, illuminazione LED interna, illuminazione LED sottobase.

**Please specify:**

A- front colour;  
M- XGlass front and top colour.  
Push-pull opening.

**Options:** cableway, IR repeater, internal LED lighting, LED lighting under base.

					Frontale A/ Front A		
L/W	P/D	A/H	Codice Code		Vetro lucido Polished glass	Vetro opaco Matt glass	XGlass*
221,6	40,6	46,4	215301				
295,2	40,6	46,4	215302				
332	40,6	46,4	215303				
368,8	40,6	46,4	215304				

\*XGlass disponibile nelle finiture lucido o opaco.  
\*XGlass available in polished or matt finishes.

# MATERIA TV UNITS - OPTIONAL//OPTIONALS

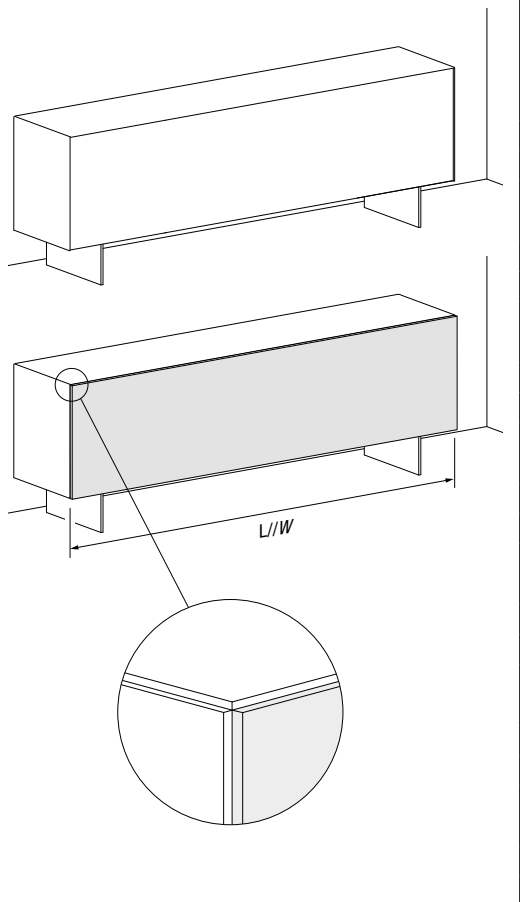
Descrizione//Description	A//H	L//W	Codice Code	Vetro lucido Polished glass	Vetro opaco Matt glass	XGlass lucido o opaco polished or matt
<p><b>Pannello bifacciale</b> Spessore 0,4 cm, incollato alla struttura <b>Double-faced panel</b> Thickness 0,4 cm, bonded to the structure</p> 	18,8	148	F32026			
		184,8	F32037			
		221,6	F32043			
		258,4	F32049			
		276	F32062			
		295,2	F32053			
		332	F32063			
	28	148	F32064			
		184,8	F32065			
		221,6	F32066			
		258,4	F32067			
		276	F32068			
		295,2	F32069			
		332	F32070			
	37,2	148	F32027			
		184,8	F32038			
		221,6	F32044			
		258,4	F32050			
		276	F32071			
		295,2	F32054			
		332	F32072			
	55,6	221,6	F32046			
		258,4	F32073			
		295,2	F32074			
		332	F32075			

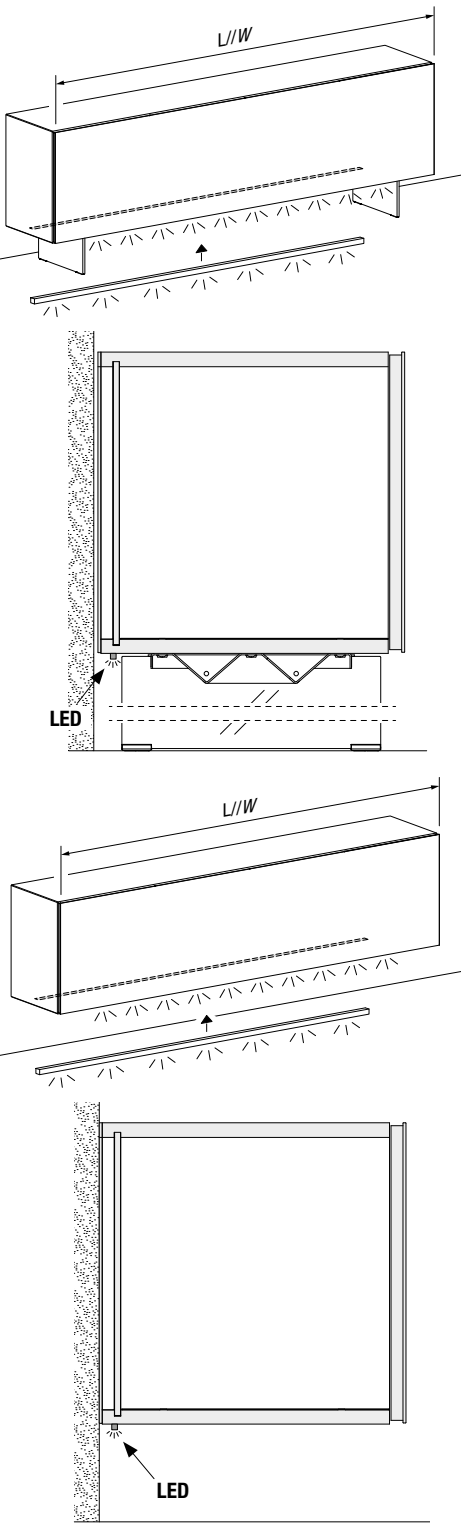
Descrizione//Description	Larghezza Width	Watt	Codice Code	LED
<p><b>illuminazione LED sottobase</b> 3000° K, fissaggio con clip, accensione con sensore (incluso). Alimentatore non incluso. <b>LED lighting under base</b> 3000° K, clip, control with sensor (included). Power unit not included.</p> 	<p>36,8</p> <p>73,6</p> <p>110,4</p> <p>147,2</p> <p>184</p> <p>202,4</p> <p>220,8</p> <p>239,2</p> <p>257,6</p> <p>276</p> <p>294,4</p> <p>312,8</p>	<p>4,2</p> <p>8,8</p> <p>13,2</p> <p>17,7</p> <p>22,1</p> <p>24,3</p> <p>26,5</p> <p>28,7</p> <p>30,9</p> <p>32</p> <p>35,3</p> <p>36</p>	<p>D20079</p> <p>D20078</p> <p>D20061</p> <p>D20063</p> <p>D20065</p> <p>D20066</p> <p>D20067</p> <p>D20068</p> <p>D20069</p> <p>D20080</p> <p>D20070</p> <p>D20081</p>	
<p><b>Alimentatore 24V, 4 uscite</b> Prevedere almeno un punto luce. Non sono predisposti passaggi di cavi. <b>Power unit 24V, 4 outputs</b> At least one light required. Not set up for cables to pass through.</p>	<p><b>Watt</b></p> <p>30</p> <p>60 W a 110V per mercato USA 60 W with 110V for US market</p>		<p><b>Codice Code</b></p> <p>D20008</p>	<p><b>Alimentatore Power supply</b></p>

# MATERIA TV UNITS - OPTIONAL//OPTIONALS

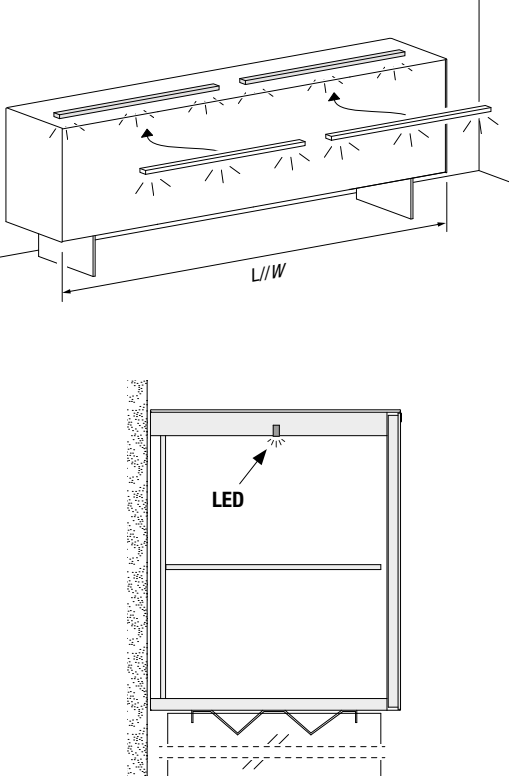
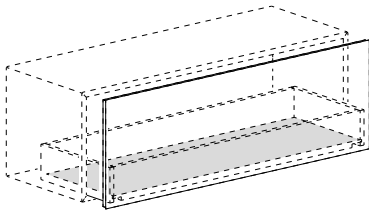
Descrizione//Description	Codice articolo Item code		Larghezza Width		Illuminazione Lighting	
<p><b>Illuminazione LED interna</b> 3000° K, accensione con sensore (incluso). Trasformatore incluso.</p> <p><b>Internal LED lighting</b> 3000° K, control with sensor (included). Transformer included.</p> 	1048B - 1048C - 1048D		148 184,8 221,6 258,4 295,2 332 368,8 405,6 442,4			
	1476		221,6 258,4 295,2 332 368,8 405,6			
	1479		221,6 258,4 295,2 332			
	2153		221,6 295,2 332 368,8			
<p><b>Fondi in vetro per interno cassetto e/o cestone</b> Glass bottoms for standard/large drawer inside</p>  <p>* Per contenitori con divisori interni previsti 2 o 3 fondi in base all'articolo. * For storage units with internal partitions, consider 2 or 3 bottoms depending on the item.</p>	Profondità Depth	Larghezza Width	Codice Code	Vetro lucido Polished glass	Vetro opaco Matt glass	XGlass lucido o opaco polished or matt
	40,6	73,6	TER7203			
		92	TER7207			
		110,4 (*)	TER7204			
		147,2 (*)	TER7205			
		184 (*)	TER7206			
		220,8 (*)	TER7226			

# Vetro lucido

EN Polished glass / ES Cristal brillante / FR Verre brillant / DE Glas poliert

Il vetro LAGO cattura lo sguardo con una nuova esperienza del colore, reso vivo, profondo e mutevole al variare delle condizioni della luce. Rigorosamente perfetto, mantiene inalterata attraverso il tempo la propria bellezza. Il vetro ha doti intrinseche di igienicità, facile da pulire in quanto non assorbe lo sporco e le macchie e temperato, ovvero trattato termicamente per ottenere una elevata resistenza all'urto, al graffio e al calore. Viene verniciato all'acqua ed è un materiale riciclabile al 100%.

LAGO glass captures the eye with a new experience of colour, made brilliant, deep and changeable according to light conditions. Rigorously perfect, it preserves its beauty unaltered over time. LAGO glass has intrinsic hygienic properties, it is easy to clean since it does not absorb dirt or stains and it is tempered, that is to say temperature-treated in order to obtain higher resistance to shocks, scratches and heat. It is painted with water-based colour and is a 100% recyclable material.

El vidrio LAGO cautiva la mirada con una nueva forma de vivir el color, vuelto vivo, profundo y cambiante al variar las condiciones de luz. Rigorosamente perfecto, mantiene inalterada en el tiempo su belleza. El vidrio tiene características intrínsecas que lo hacen un material limpio: es fácil de lavar ya que no absorbe la suciedad ni las manchas, y con el templado es tratado térmicamente para obtener una alta resistencia a los golpes, las ralladuras y el calor. Está barnizado al agua y es un material 100% reciclable.

Le verre LAGO accroche le regard avec une nouvelle expérience de la couleur, rendue vive, profonde et changeante en fonction des variations lumineuses. Rigoureusement parfait, il conserve une beauté inaltérée à travers le temps. Le verre a des qualités hygiéniques intrinsèques: il est facile à nettoyer, car il n'absorbe ni la saleté ni les taches, et est trempé, c'est-à-dire traité thermiquement pour renforcer sa résistance aux chocs, aux rayures et à la chaleur. Verni à l'eau, ce matériau est 100 % recyclable.

Das LAGO-Glas lenkt den Blick mit einem neuen Farberlebnis auf sich, das sich Stunde um Stunde mit den Verhältnissen des Lichts als lebendig, tiefgründig und veränderbar erweist. Auf perfekte Art und Weise behält es strengstens seine Schönheit, die sich im Laufe der Zeit kein bisschen verändert. Das Glas verfügt über die einmalige Gabe der Reinheit. Es ist leicht zu reinigen, da es keinen Schmutz und keine Flecken aufnimmt; es ist für eine höhere Resistenz Stößen, Kratzern und Hitze gegenüber temperiert bzw. wärmebehandelt. Es wird mit Farben auf Wasserbasis gestrichen und ist ein 100%ig recyclefähiges Material.



La rappresentazione dei colori ha valore indicativo / The colour representation is indicative / La representación de los colores tiene valor indicativo / La représentation des couleurs est indicative / Die abgebildeten Farben können vom Original abweichen.



# Vetro opaco

EN Matt glass / ES Cristal mate / FR Verre mat / DE Glas satiniert

Grazie a un processo di acidatura delle lastre, il vetro opaco LAGO crea nuovi linguaggi compositivi mescolando la perfezione tattile e formale di questo materiale con un effetto visivo sorprendente. Più delicato del vetro lucido ha doti di igienicità ed è temperato, ovvero trattato termicamente per ottenere una elevata resistenza all'urto, al graffio e al calore. Il vetro viene verniciato all'acqua ed è un materiale riciclabile al 100%.

Thanks to an acidizing process, LAGO opaque glass creates new compositional languages, mixing the tactile and formal perfection of this material with a surprising visual effect. More delicate than shiny glass, it has hygienic properties and is tempered, that is to say temperature-treated in order to obtain higher resistance to shocks, scratches and heat. LAGO opaque glass is painted with water-based colour and is a 100% recyclable material.

Gracias a un proceso de acidificación de las láminas, el vidrio opaco LAGO crea nuevos lenguajes compositivos mezclando la perfección táctil y formal de este material con un efecto visual sorprendente. Más delicado que el vidrio brillante, tiene cualidades higiénicas y está templado, es decir tratado térmicamente para obtener una alta resistencia a los golpes, las ralladuras y el calor. El vidrio está barnizado al agua y es un material 100% reciclable.

Grâce à un procédé de traitement à l'acide des plaques, le verre opaque LAGO crée de nouveaux langages de composition, en mêlant la perfection tactile et formelle de ce matériau avec un effet visuel saisissant. Plus délicat que le verre poli, il est hygiénique et trempé, c'est-à-dire traité thermiquement pour une meilleure résistance au chocs, aux rayures et à la chaleur. Ce verre verni à l'eau est un matériau 100 % recyclable.

Dank einer Säurebehandlung der Scheiben, erfindet das Mattglas von LAGO eine neue Kompositionssprache, indem es die tastbare und formale Perfektion dieses Materials mit einem offensichtlichen, erstaunlichen Effekt vereint. Es ist delikater als transparentes Glas und verfügt über hygienische Eigenschaften; ist für eine höhere Resistenz Stößen, Kratzern und Hitze gegenüber temperiert bzw. wärmebehandelt. Es wird mit Farben auf Wasserbasis gestrichen und ist ein 100%ig recyclefähiges Material.



La rappresentazione dei colori ha valore indicativo / The colour representation is indicative / La representación de los colores tiene valor indicativo / La représentation des couleurs est indicative / Die abgebildeten Farben können vom Original abweichen.

# Vetro Metal lucido e opaco

<sup>EN</sup> Polished and matt Metal Glass / <sup>ES</sup> Cristal Metal brillante es mate / <sup>FR</sup> Verre Métal brillant et mat / <sup>DE</sup> Glas Metal poliert und satiniert

Tre colorazioni dai riflessi metallici caldi e cangianti avvolgono le superfici in modo uniforme, donando dinamismo e luminosità al prodotto nelle diverse finiture, lucida e opaca. Colori vivi che producono eleganti effetti visivi al variare della luce naturale e domestica. Realizzati con prodotti all'acqua privi di solventi, garantiscono igienicità e resistenza nel tempo grazie alle proprietà intrinseche del vetro.

Three shimmering metallic colours dominate the surface evenly, creating a bright, warm and dynamic look, available in a range of matt and polished finishes. Vivid colours create elegant visuals as the light changes both indoors and outdoors. Produced using solvent-free, water-based products, your furniture is hygienic and durable over time, thanks to the intrinsic qualities of glass.

Tres coloraciones de reflejos metálicos cálidos y cambiantes envuelven las superficies de manera uniforme, dando dinamismo y luminosidad al producto en los diferentes acabados brillo y mate. Colores vivos que producen elegantes efectos visuales al variar la luz natural y doméstica. Realizados con productos al agua sin disolventes, garantizan higiene y resistencia a lo largo del tiempo gracias a las propiedades intrínsecas del cristal.

Trois coloris aux reflets métalliques chauds et chatoyants enveloppent les surfaces de manière uniforme, tout en donnant dynamisme et luminosité au produit dans les différentes finitions, brillantes et mates. Des couleurs vives qui produisent d'élégants effets visuels selon la variation de la lumière naturelle et domestique. Réalisés avec des produits à l'eau sans solvants, ils garantissent hygiène et résistance dans le temps grâce aux propriétés intrinsèques du verre.

Drei Farben mit warmen, changierenden Metallic-Reflexen umhüllen die Oberflächen gleichmäßig und verleihen dem Produkt in den verschiedenen Ausführungen – glänzend und matt – Dynamik und Helligkeit. Lebendige Farben, die bei wechselndem natürlichem und häuslichem Licht elegante visuelle Effekte erzeugen. Sie werden mit lösungsmittelfreien Produkten auf Wasserbasis hergestellt und garantieren dank der charakteristischen Eigenschaften von Glas Hygiene und Haltbarkeit.

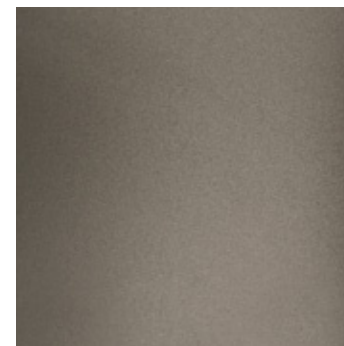

CHAMPAGNE METAL

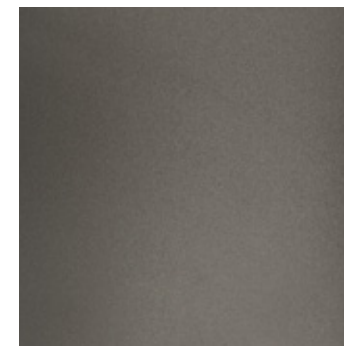

PIOMBO METAL

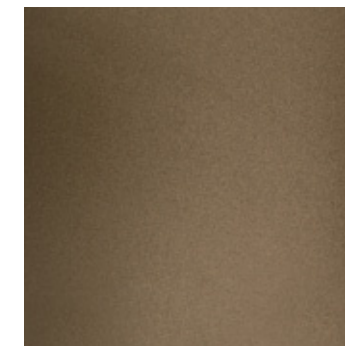

TUNDRA METAL

# XGlass lucido e opaco

EN Polished and matt XGlass / ES XGlass brillante es mate / FR XGlass brillant et mat / DE XGlass poliert und satiniert

La rivoluzione tecnologica sta accelerando i processi di innovazione anche nel campo dei materiali, offrendo opportunità incredibili. Grazie alla digital print XGlass coniuga le qualità di un materiale nobile e prezioso come il vetro alle emozioni di molteplici materiali. Le diverse finiture, lucida e opaca, aumentano poi l'empatia con il materiale stesso. Una raffinata continuità di pattern connota le superfici dei prodotti. XGlass è una strategia innovativa anche per poter ridurre in più casi l'impatto ambientale e migliorare quello sociale.

The technological revolution is speeding up innovation and offering incredible opportunities, including in the field of materials. Using digital printing technology, XGlass combines the fine qualities of glass with the emotion of a whole range of other materials. The different finishes, available in glossy and mat, increase empathy with the material itself and a refined continuous pattern defines the surface of each piece. XGlass is also an innovative solution for reducing environmental impact in many cases and improving the social one.

La révolution technologique accélère les processus d'innovation même dans le domaine des matériaux et ouvre la voie à d'incroyables opportunités. Grâce à l'impression numérique, XGlass combine les qualités d'un matériau noble et précieux comme le verre aux émotions de plusieurs matériaux. Les diverses finitions, brillante et opaque, intensifient l'empathie avec le matériau lui-même. Cette continuité raffinée de motifs caractérise les surfaces des produits. XGlass est également une stratégie innovante qui permet de réduire, dans de nombreux cas, l'incidence environnementale et d'améliorer l'impact social.

La revolución tecnológica está acelerando los procesos de innovación en el campo de los materiales, ofreciendo oportunidades increíbles. Gracias a la impresión digital, XGlass conjuga las cualidades de un material noble y preciado como el cristal con las emociones de múltiples materiales. Los diferentes acabados, brillo y mate, aumentan también la empatía con el material mismo. Una elegante continuidad de estampados distinguen las superficies de los productos. XGlass es una estrategia innovadora también para poder reducir en más casos el impacto ambiental y mejorar el social.

Die technologische Revolution beschleunigt Innovationsprozesse auch im Bereich der Materialien und bietet unglaubliche Möglichkeiten. Dank des Digitaldrucks verbindet XGlass die Eigenschaften eines edlen und kostbaren Materials wie Glas mit den Emotionen vieler Materialien. Die verschiedenen Ausführungen, die glänzend und matt erhältlich sind, sorgen für noch mehr Begeisterung. Ein raffinierter Übergang der Muster auf der Oberflächen gibt den Produkte ihren besonderen Charakter. XGlass ist ein innovative Instrument zur Verringerung der Umweltbelastung und zur Verbesserung der sozialen Auswirkungen.

## MARBLE XGLASS

Gamma completa - Complete range - Amplia gama - Gamme complète - Umfassende Palette

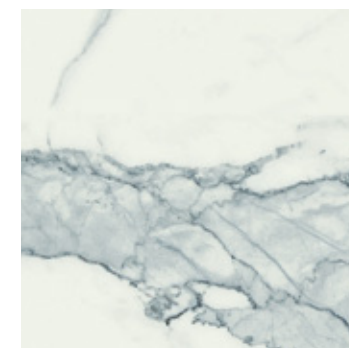

STATUARIO



PAONAZZO



CALACATTA GOLD



ONICE GRIGIO

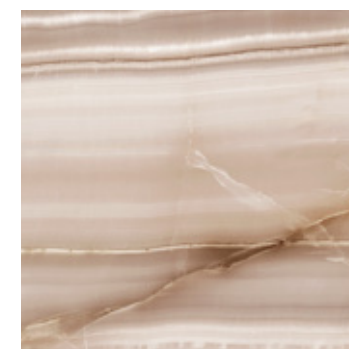

ONICE

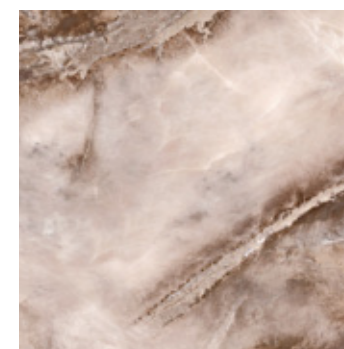

ALABASTRO

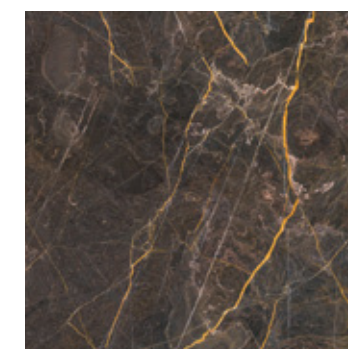

PORT SAINT LAURENT

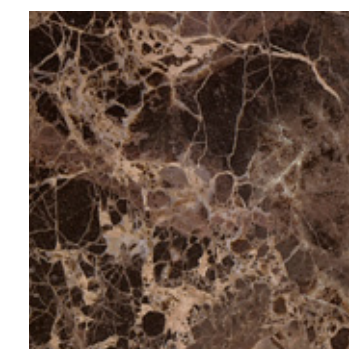

EMPERADOR

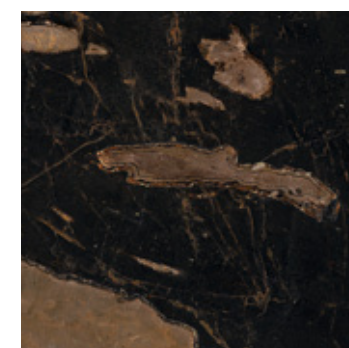

GEODE

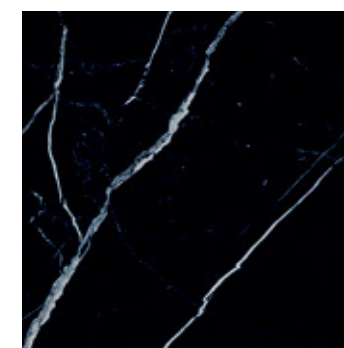

MARQUINA

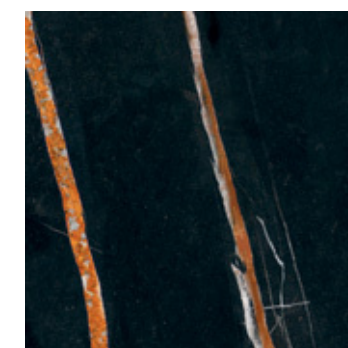

SAHARA NOIR

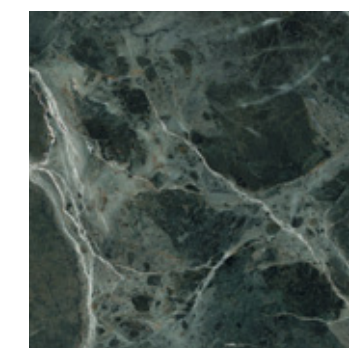

VERDE ALPI

# MARBLE XGLASS

Scala 1:3 - Scale 1:3 - Escala 1:3 - Échelle 1:3 - Maßstab 1:3

3 m

2 m

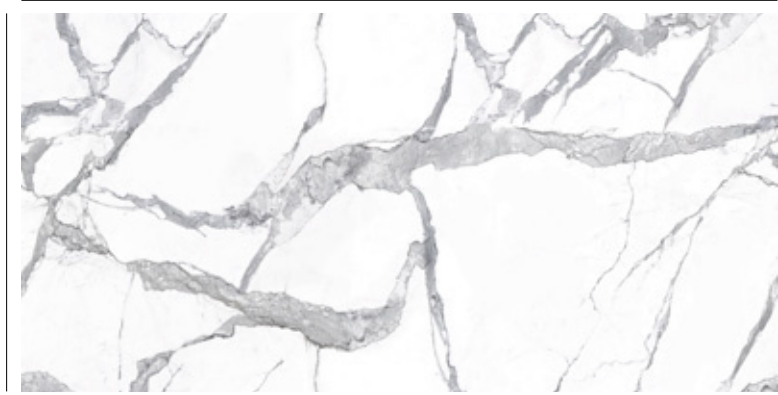

STATUARIO



PAONAZZO

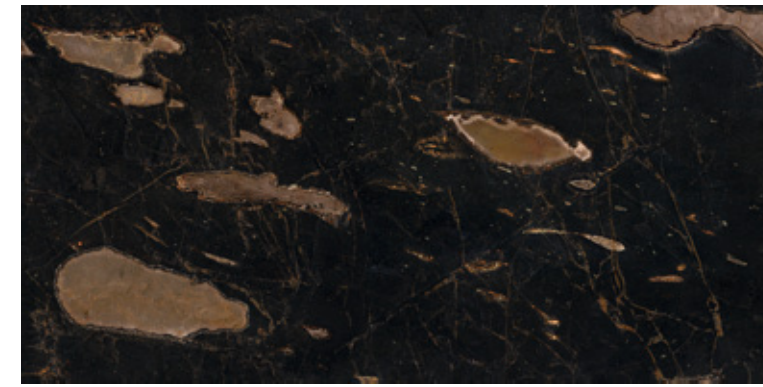

GEODE

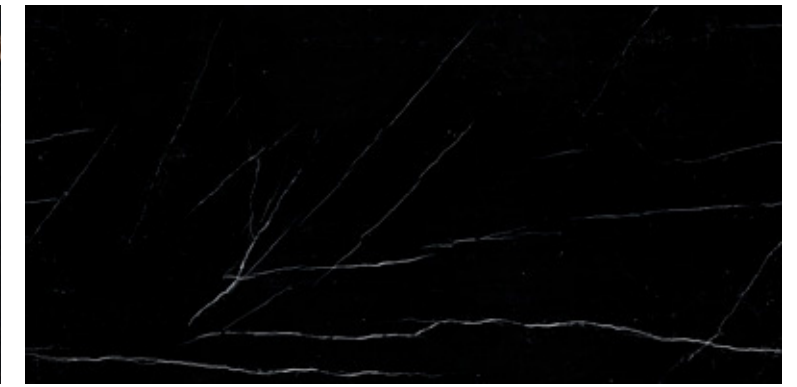

MARQUINA



CALACATTA GOLD



ONICE GRIGIO

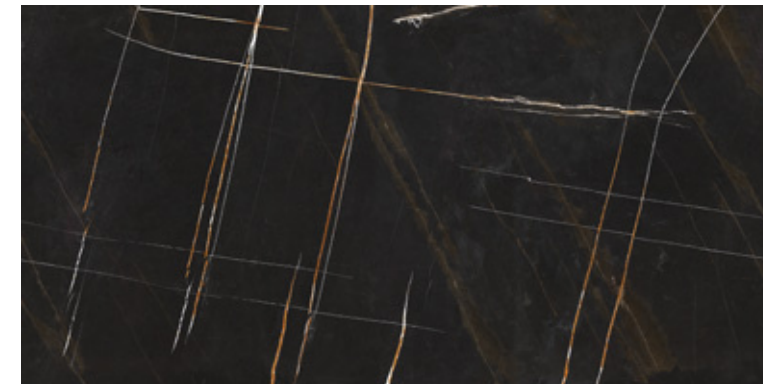

SAHARA NOIR

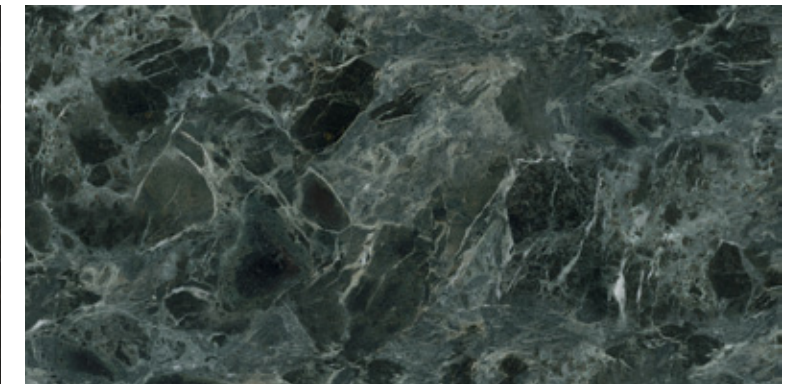

VERDE ALPI

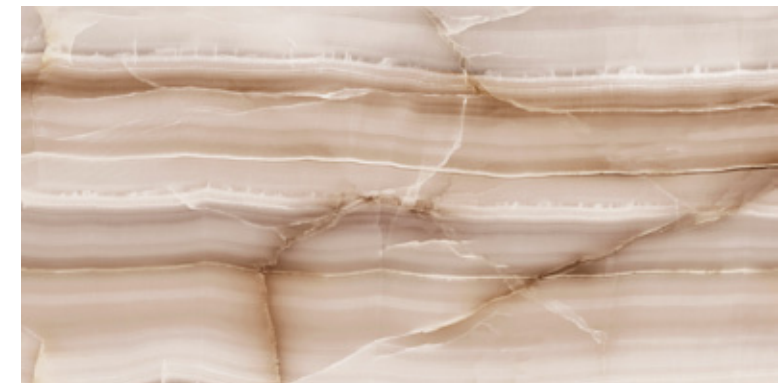

ONICE

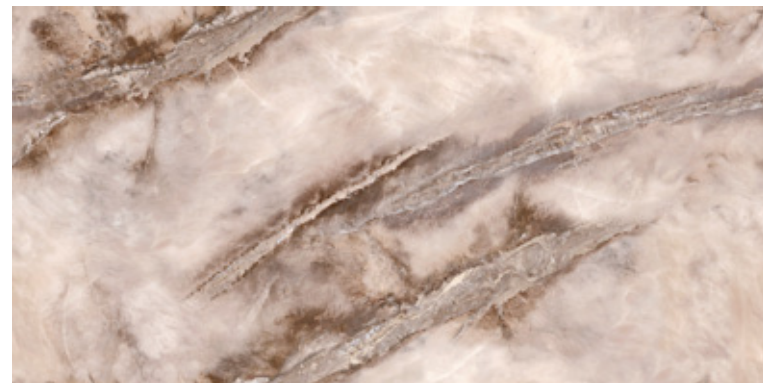

ALABASTRO

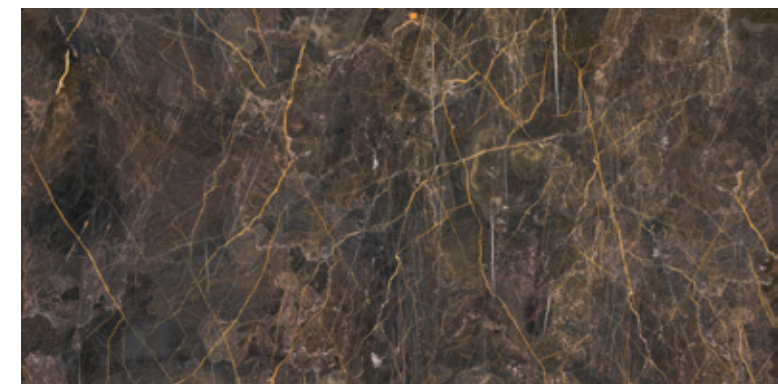

PORT SAINT LAURENT



EMPERADOR

## METAL XGLASS



TITANIO

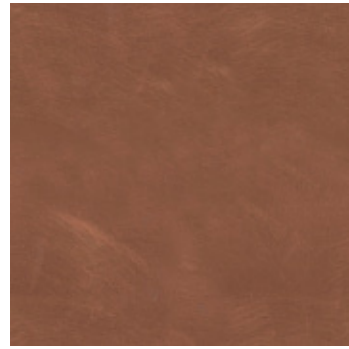

RAME

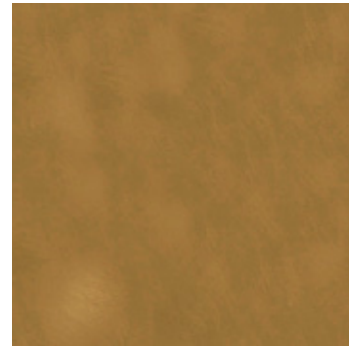

ORO



BRONZO



PELTRO

## HOME COUTURE XGLASS

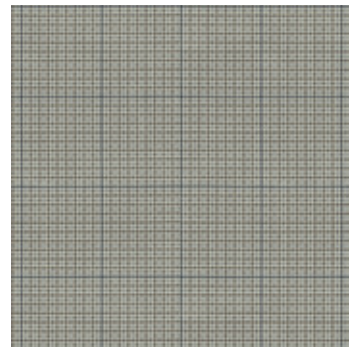

KISS WOOL

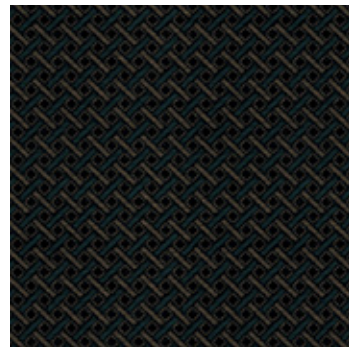

POP PANTS

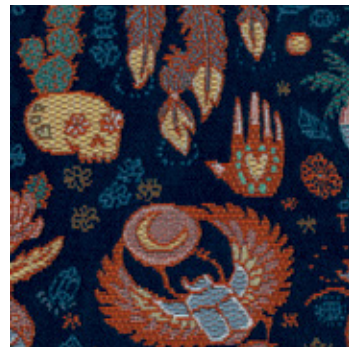

ART & CRAFT

## ANIMAL ZERO XGLASS\*

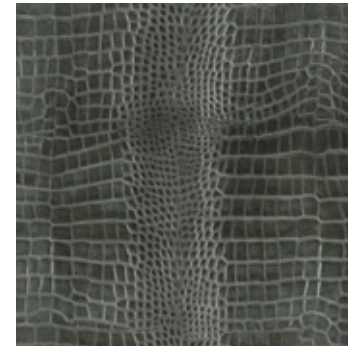

COCCODRILLO VERDE

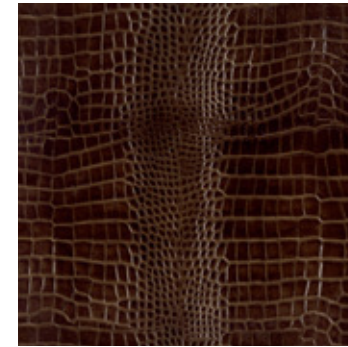

COCCODRILLO MARRONE

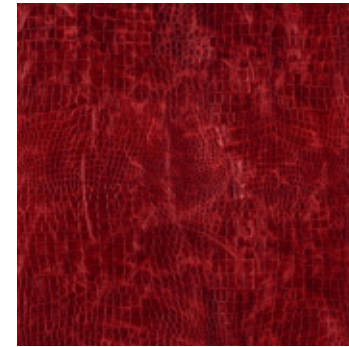

COBRA ROSSO

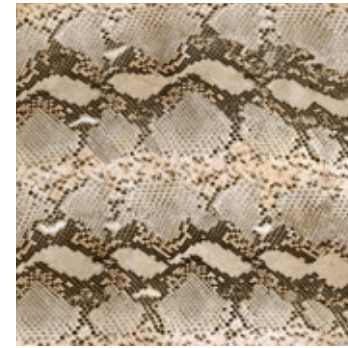

PITONE

*\*Disponibile solo nella versione lucida. / Available only in the polished version. / Disponible sólo en la versión brillante. / Disponible uniquement en version brillant. / Nur in der poliert Version erhältlich.*

## WOOD XGLASS

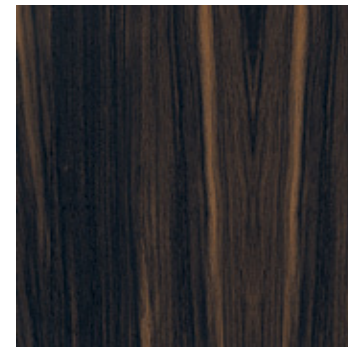

EBANO MACASSAR

# Aqua

L'eleganza intrinseca del vetro opaco combinata alla sua raffinata lavorazione tridimensionale, dà vita a un materiale dalla piacevole sensazione tattile. Grazie a questa particolare tecnica decorativa del vetro, le luci trasformano le superfici, modificando anche la percezione visiva delle finiture, che spaziano dal laccato all'XGlass.

Intrinsically elegant matt glass combined with a sophisticated three-dimensional processing technique creates a pleasantly tactile material. With this special glass decoration technique, the surfaces transform in the light, altering the look of the finishes ranging from lacquer to XGlass.

L'élégance intrinsèque du verre mat, alliée à son usinage raffiné en trois dimensions, donne vie à un matériau offrant une agréable sensation tactile. Grâce à cette technique spécifique de décoration du verre, les lumières transforment les surfaces et modifient également la perception visuelle des finitions qui vont du laqué au XGlass.

La elegancia intrínseca del cristal mate combinada con su refinada elaboración tridimensional da vida a un material de agradable sensación táctil. Gracias a esta singular técnica decorativa del cristal las luces transforman las superficies, modificando también la percepción visual de los acabados, que van del lacado al XGlass.

Die inhärente Eleganz von opakem Glas schafft ein Material mit einer angenehmen Haptik. Dank dieser speziellen Glasdekorationstechnik verwandeln Lichter die Oberflächen und verändern auch die visuelle Wahrnehmung der Ausführungen, die von lackiert bis XGlass reichen.

## Aqua Vetro Opaco

Aqua Matt glass / Aqua Cristal mate / Aqua Verre mat / Aqua Glas satiniert

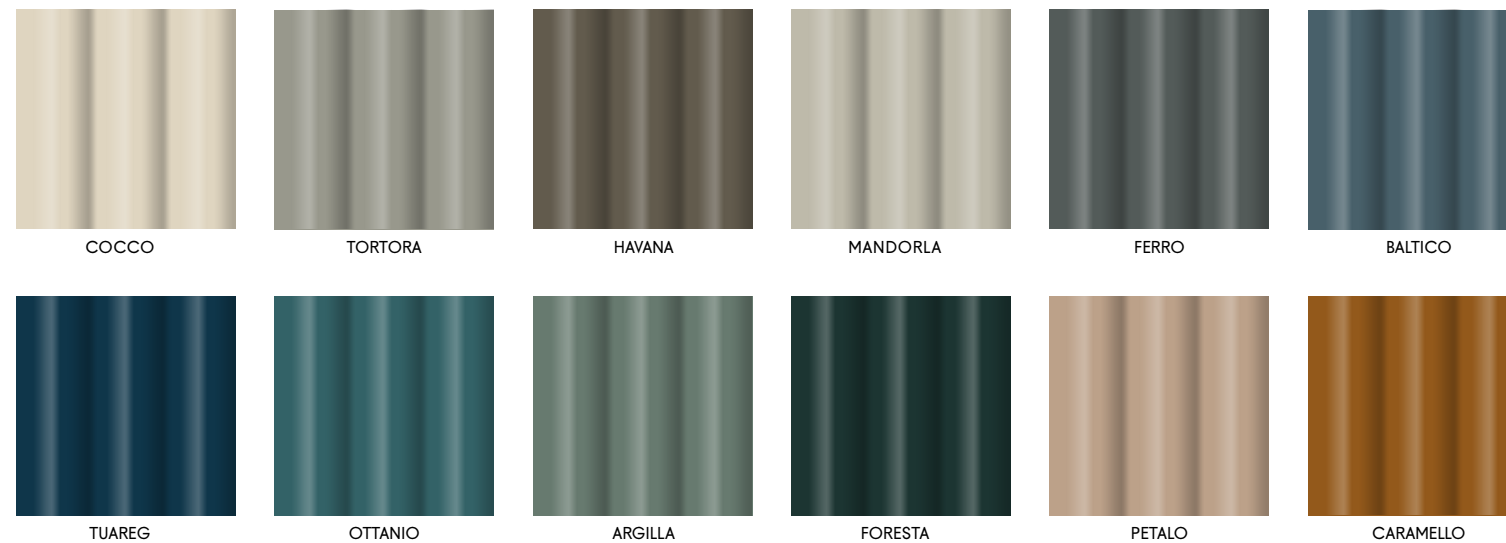

## Aqua XGlass opaco

Aqua matt XGlass / Aqua XGlass mate / Aqua XGlass mat / Aqua XGlass satiniert

