

ET VOILÀ

Wardrobe

^{IT} L'armadio Et Voilà, frutto di un progetto estremamente innovativo, si apre con un semplice gesto per poi scomparire nell'architettura: un tessuto e teso di grandi dimensioni infatti sostituisce le ante eliminando la percezione dell'armadio, che diventa una raffinata parete tessile. Progettabile al millimetro, permette di cambiare facilmente il look della stanza e contribuisce al comfort acustico grazie alle proprietà fonoassorbenti e alla silenziosità del meccanismo di scorrimento.

^{ES} El armario Et Voilà, fruto de un diseño extremadamente innovador, se abre con un simple gesto para después desaparecer en la arquitectura: una tela tensada de grandes dimensiones sustituye en efecto las puertas eliminando la percepción del armario, que se convierte en una elegante pared de tela. Proyectable al milímetro, permite cambiar fácilmente el look de la habitación y contribuye al confort acústico gracias a sus propiedades de absorción del sonido y al silencioso mecanismo de desplazamiento en la apertura.

^{DE} Als Ergebnis eines höchst innovativen Projekts öffnet sich der Kleiderschrank Et Voilà Wardrobe mit einem einfachen Handgriff, um dann in der Architektur zu verschwinden: So ersetzt ein gespannter Stoff mit großen Abmessungen die Schranktüren und lässt den Kleiderschrank praktisch unsichtbar werden, indem er ihn in eine raffinierte textile Wand verwandelt. Ein Kleiderschrank, der sich auf den Millimeter genau planen lässt, dem Raum leicht einen neuen Look schenkt und dank schallabsorbierender Eigenschaften und seines leisen Gleitmechanismus zum akustischen Raumkomfort beiträgt.

^{EN} The Et Voilà wardrobe is the result of a highly innovative project: simple to open, when closed it disappears into the architecture. A large taut piece of fabric is in fact used in place of doors, completely doing away with the perception of the wardrobe itself, which becomes a refined textile wall. Instantly changing the look of any room, it can be designed to the millimetre and also contributes to acoustic comfort thanks to its sound absorbent properties and its silent gliding mechanism.

^{FR} Le placard Et Voilà, fruit d'un projet extrêmement innovant, s'ouvre d'un simple geste pour ensuite se fondre dans l'architecture: en effet, un tissu tendu de grandes dimensions remplace les portes et élimine la perception du placard, qui devient une paroi textile raffinée. Réalisable au millimètre près, il permet de changer facilement le look de la pièce et contribue au confort sonore grâce à ses propriétés phono-isolantes et au fonctionnement silencieux de son mécanisme de coulissement.



Design Daniele Lago · 2011



ET VOILÀ WARDROBE 1173 - Cocco Stratus fabric front.

W 379,5 cm / D 65,4 cm / H 265 cm





ET VOILÀ WARDROBE 1174 - 03 Stratus fabric front.

W 406 cm / D 65,4 cm / H 265 cm



ET VOILÀ WARDROBE 1175 - Pop Pants dark Stratus fabric front.

W 309,5 cm / D 65,4 cm / H 227 cm

^{IT} **Delicata sospensione** - Et Voilà, dotato di un sistema di installazione testato per una sospensione in sicurezza, restituisce grande leggerezza agli spazi ottimizzando la fruizione degli stessi. // ^{EN} **Delicate suspension** - Et Voilà is fitted with an installation system tested for safe suspension, lending great weightlessness to any space and optimising storage. // ^{ES} **Delicada suspensión** - Et Voilà, dotado de un sistema de instalación testado para una suspensión con seguridad, dona gran ligereza a los espacios optimizando su disfrute. // ^{FR} **Suspension délicate** - Doté d'un système d'installation testé pour une suspension en toute sécurité, Et Voilà offre une grande légèreté aux espaces en optimisant leur utilisation. // ^{DE} **Schwebende Wandmontage** - Et Voilà ist mit einem getesteten Montagesystem für eine sichere Wandmontage ausgestattet und verleiht dem Raum so nicht nur eine große Leichtigkeit, sondern optimiert auch dessen Nutzung.



ET VOILÀ WARDROBE 1177 - Kiss Wool dark Stratus fabric front.
Fineline oak melamine backs.

W 197,5 cm / D 65,4 cm / H 184 cm



ET VOILÀ WARDROBE 1176 - Kiss Wool gentle Stratus fabric front.

W 309,5 cm / D 65,4 cm / H 265 cm



^{IT} **Tecnologia tessile** - Il tessuto, morbido e raffinato, ha un'anima tecnica e una trama che impedisce alla polvere di filtrare all'interno, sviluppato appositamente per tale progetto, garantisce una fonoassorbenza che rende gli ambienti morbidi e ovattati e si distingue per agevolare manutenzione e lavabilità. // ^{EN} **Textile technology** - This soft refined fabric has been developed specifically for this project with a technical core and weave that prevents dust filtering through. It guarantees sound-absorbency that gives a softly cushioned feel to the room and is amazingly easy to care for and wash. // ^{ES} **Tecnología textil** - La tela, blanda y refinada, tiene un alma técnica y una trama que impide al polvo filtrarse hacia el interior, desarrollada a propósito para tal fin, garantizando una absorción del sonido que vuelve los ambientes blandos y atenuados y se distingue por facilitar el mantenimiento y el lavado. // ^{FR} **Technologie textile** - Le tissu, souple et raffiné, a une âme technique et une trame qui empêche la poussière de filtrer à l'intérieur. Conçu spécialement pour ce projet, il garantit un confort acoustique qui rend les espaces souples et ouatés et se distingue par sa facilité d'entretien et de nettoyage. // ^{DE} **Textiltechnik** - Das weiche und raffinierte Gewebe mit technischer Seele und einer Webart, die das Eindringen von Staub gewährleistet, wurde eigens für dieses Projekt entwickelt. Es garantiert eine Schallabsorption, die für eine wattierte Raumakustik sorgt, und zeichnet sich durch seine einfache Pflege und Waschbarkeit aus.



ET VOILÀ WARDROBE 1179 - Bomber tatoo dark Stratus fabric front.

W 276,5 cm / D 65,4 cm / H 227 cm

Stratus

Solo per Et Voilà / Only for Et Voilà / Sólo para Et Voilà / Uniquement pour Et Voilà / Nur für Et Voilà

Sviluppati per LAGO da manifatture italiane, questi tessuti sono un morbido e versatile condensato di tecnologia, sapienza artigiana e creatività. Texture contemporanee e una gamma di colori pensati per vestire la casa trasformano trame e orditi in risorsa per realizzare habitat accoglienti e dalla personalità unica. Certificato ÖKO-TEX Standard 100 quale tessuto privo di sostanze dannose per l'uomo e per l'ambiente.

Developed for LAGO by Italian manufacturers, these fabrics are a soft, versatile condensing of technology, artisan wisdom and creativity. Modern textures and a colour range designed to dress the home, transforming warp and weft into a resource for creating welcoming habitats with unique personality. ÖKO-TEX Standard 100 certified to be a fabric free of substances damaging to people and the environment.

Desarrollados para LAGO por manufactureras italianas, estos tejidos son un suave y versátil compendio de tecnología, sabiduría artesana y creatividad. Texturas contemporáneas y una gama de colores pensados para vestir la casa, transformando tramas y urdimbres en recursos para realizar hábitats acogedores y de personalidad única. Certificado ÖKO-TEX Standard 100 como tejido libre de sustancias dañinas para el hombre o para el medio ambiente.

Réalisés pour LAGO par des manufactures italiennes, ces nouveaux tissus sont un condensé souple et versatile de technologie, de sagesse artisanale et de créativité. Des textures contemporaines et une gamme de coloris conçus pour vêtir la maison transforment chaînes et trames en une ressource donnant vie à une habitation accueillante et à la personnalité unique. Certifié par ÖKO-TEX Standard 100 tissu sans substances nocives pour l'homme et l'environnement.

Von italienischen Handarbeitsbetrieben für LAGO entwickelt, sind diese Stoffe ein weiches und vielseitiges Konzentrat der Technologie, handwerklichen Weisheit und Kreativität. Die zeitgemäßen Strukturen und reichhaltige Farbpalette, die erdacht wurden, um die eigenen vier Wände neu einzukleiden, verwandeln Schuss- und Kettfäden in eine einmalige Ressource zur Erschaffung gemütlicher und einladender Wohnräume, die über eine ganz eigene und einzigartige Persönlichkeit verfügen. Das ÖKO-TEX Zertifikat Standard 100 steht für ein Gewebe, das frei von schädlichen Stoffen, sowohl für den Menschen als auch für die Umwelt, ist.

Composizione: 100% poliestere misto rigenerato. Tessuto ottenuto con fibre riciclabili.

Composition: 100% mixed regenerated polyester. Fabric made with recycled fibres.

Composición: 100% poliéster mixto regenerado. Tejido obtenido con fibras reciclables.

Composition: 100% polyester mélangé régénéré. Tissu obtenu à partir de fibres recyclées.

Zusammensetzung: 100% aufgearbeiteter Mischpolyester. Stoff aus wiederverwerteten Fasern hergestellt.



* Vedi pag. 90 / See page 90 / Ver pág. 90 / Voir page 90 / Siehe S. 90

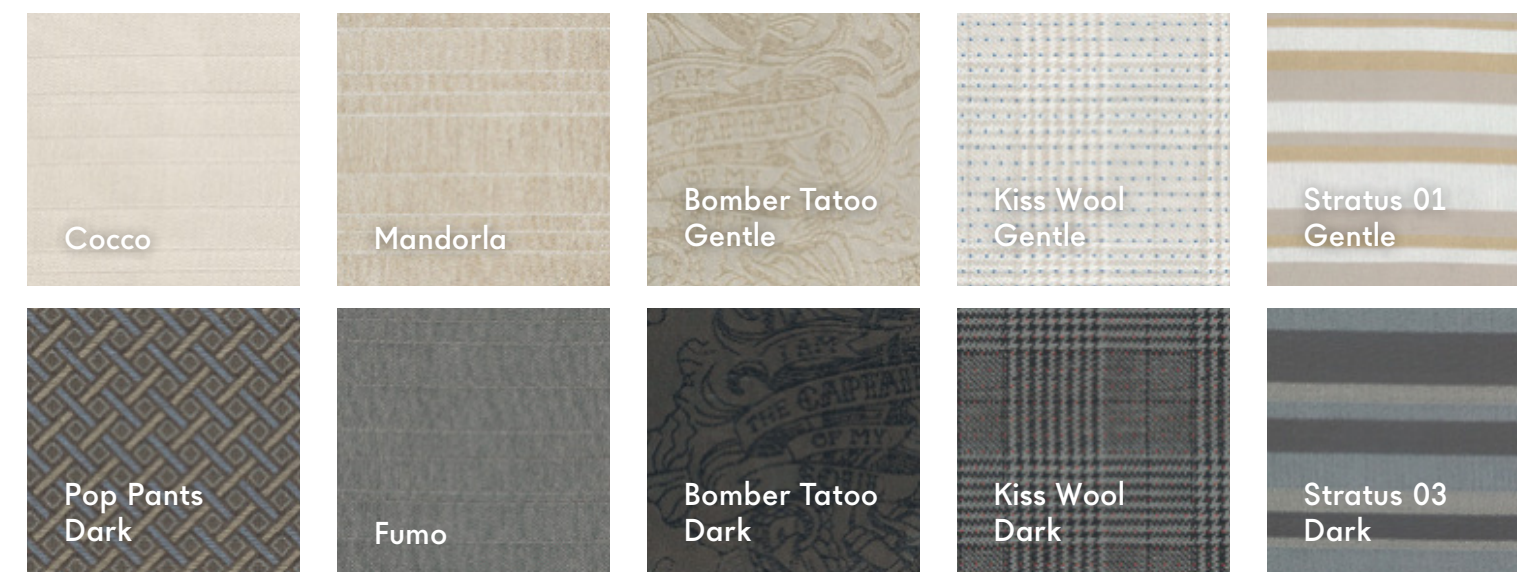

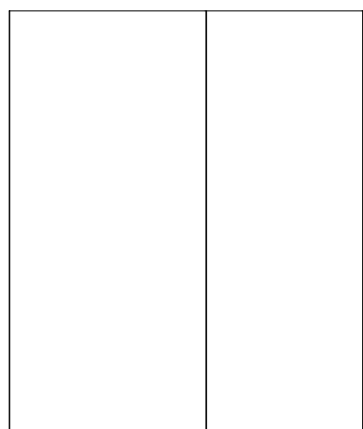

H minima consigliata dal pavimento 20 cm.
Recommended minimum height (h) from floor 20 cm.

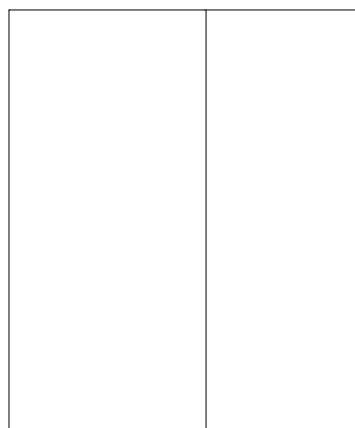

Utilizzo del fondo di finitura consigliato per H > 90 cm.
Optional finishing bottom recommended for H > 90 cm.

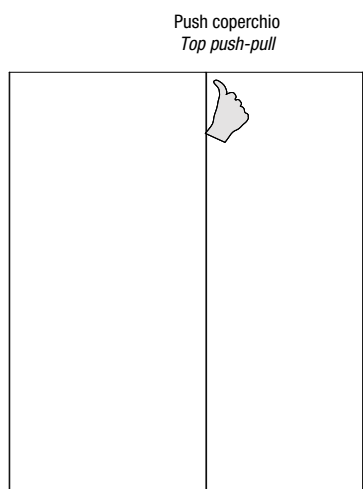

Push coperchio
Top push-pull

Per H di montaggio minore di 38,5 cm dal pavimento il push è sul coperchio del vano.
If fitting height is < 38,5 cm from floor, push-pull will be fixed on the compartment top.

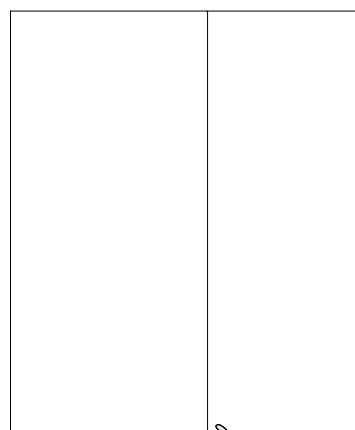

Push fondo
Bottom push-pull

Per H di montaggio maggiore di 38,5 cm dal pavimento il push è sul fondo del vano.
If fitting height is > 38,5 cm from floor, push-pull will be fixed on the compartment bottom.





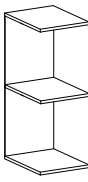
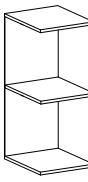
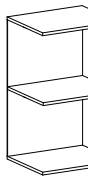
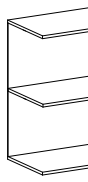
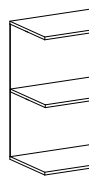
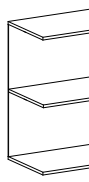
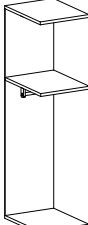
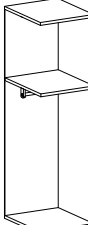
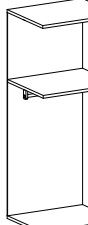
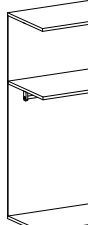
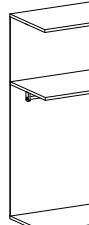
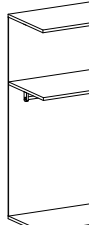
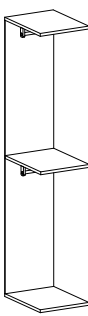
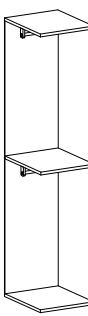
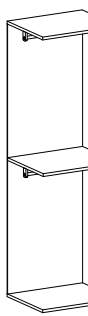
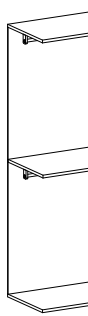
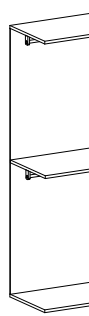
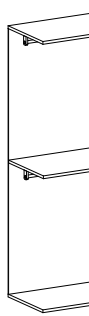





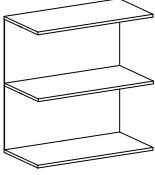

ET VOILÀ_WARDROBE

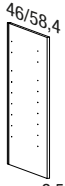
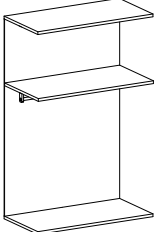
ET VOILÀ_WARDROBE - STRUTTURA A VANI//COMPARTMENT STRUCTURE

			43,5	47,5	68,5	89,5	97,5	99,5
<p>H 73,6-110,4</p>								
			<p>P armadio P struttura wardrobe D. structure D.</p>					
53*	46	A terra//On the floor	VX01	VX13	VX25	VX37	VX49	VX61
		Sospeso//Wall-hung	VX02	VX14	VX26	VX38	VX50	VX62
65,4	58,4	A terra//On the floor	VX03	VX15	VX27	VX39	VX51	VX63
		Sospeso//Wall-hung	VX04	VX16	VX28	VX40	VX52	VX64
<p>H 147,2-184</p>								
			<p>P armadio P struttura wardrobe D. structure D.</p>					
53*	46	A terra//On the floor	VX05	VX17	VX29	VX41	VX53	VX65
		Sospeso//Wall-hung	VX06	VX18	VX30	VX42	VX54	VX66
65,4	58,4	A terra//On the floor	VX07	VX19	VX31	VX43	VX55	VX67
		Sospeso//Wall-hung	VX08	VX20	VX32	VX44	VX56	VX68
<p>H 227-243** -265**</p>								
			<p>P armadio P struttura wardrobe D. structure D.</p>					
53*	46	A terra//On the floor	VX09	VX21	VX33	VX45	VX57	VX69
		Sospeso//Wall-hung	VX10	VX22	VX34	VX46	VX58	VX70
65,4	58,4	A terra//On the floor	VX11	VX23	VX35	VX47	VX59	VX71
		Sospeso//Wall-hung	VX12	VX24	VX36	VX48	VX60	VX72

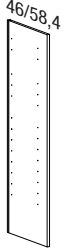
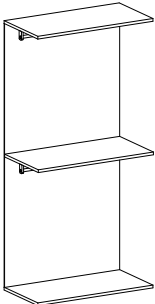
* Nella profondità 53 cm è previsto l'utilizzo delle grucce inclinate

* In the 53 cm depth it is recommended to use inclined hangers

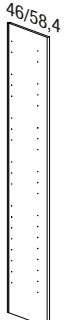
112,5		Fianco esterno External side						Fianco interno Internal side
		Nobilitato Melamine	Laccato Lacquered	Tessuto Fabric	A parete Filler side	Nobilitato Melamine		
 <p>Fianchi Sides H. 73,6-110,4</p> <p>P fianco D side</p>		 <p>2,5</p>	 <p>2,5</p>	 <p>3</p>	 <p>5,5</p>	 <p>46/58,4 2,5</p>		
VX73		51,1	A terra//On the floor	FN101	FL101	FT101	FP101	F1101
VX74			Sospeso//Wall-hung	FN102	FL102	FT102	FP102	F1102
VX75		63,5	A terra//On the floor	FN103	FL103	FT103	FP103	F1103
VX76			Sospeso//Wall-hung	FN104	FL104	FT104	FP104	F1104
 <p>Fianchi Sides H. 147,2-184</p> <p>P fianco D side</p>		 <p>2,5</p>	 <p>2,5</p>	 <p>3</p>	 <p>5,5</p>	 <p>46/58,4 2,5</p>		
VX77		51,1	A terra//On the floor	FN105	FL105	FT105	FP105	F1105
VX78			Sospeso//Wall-hung	FN106	FL106	FT106	FP106	F1106
VX79		63,5	A terra//On the floor	FN107	FL107	FT107	FP107	F1107
VX80			Sospeso//Wall-hung	FN108	FL108	FT108	FP108	F1108
 <p>Fianchi Sides H. 227 H. 243** H. 265**</p> <p>P fianco D side</p>		 <p>2,5</p>	 <p>2,5</p>	 <p>3</p>	 <p>5,5</p>	 <p>46/58,4 2,5</p>		
VX81		51,1	A terra//On the floor	FN109	FL109	FT109	FP109	F1109
VX82			Sospeso//Wall-hung	FN110	FL110	FT110	FP110	F1110
VX83		63,5	A terra//On the floor	FN111	FL111	FT111	FP111	F1111
VX84			Sospeso//Wall-hung	FN112	FL112	FT112	FP112	F1112

Il prezzo del fianco in tessuto include un solo rivestimento

The price of the fabric side includes a single covering** Strutture H 243 e 265 non disponibili versioni sospese

** H 243 and 265 structures are not available in the suspended versions

TESSUTO E BINARI//FABRIC AND RAILS

Il prezzo include:

- un frontale in tessuto;
- binari e meccanismi di scorrimento;
- profili verticali (maniglioni);

Vedi ricambio tessuto a pag. 284

The price includes:

- one fabric front;
- Rails and sliding mechanisms;
- vertical edges (handles);

See replacement fabric on page 284

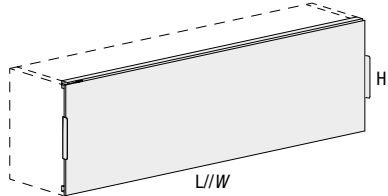
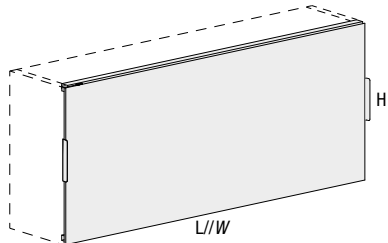
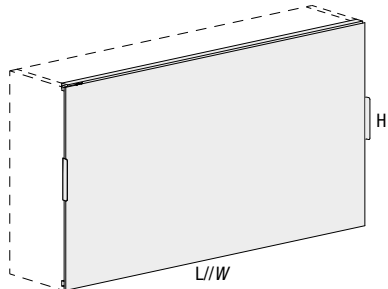
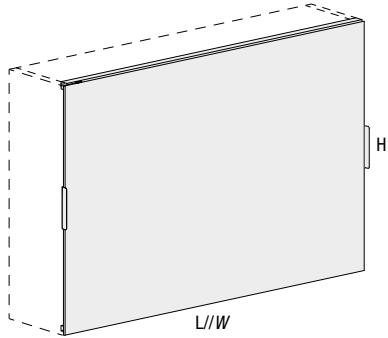
Descrizione//Description	H	Da L a L From W to W	Codice Code	Tessuto Fabric
 <p>Maniglie posizionabili liberamente in altezza Handles which can be positioned freely in height</p>	73,6	110,4 ⇔ 140	VZ110	
		140,1 ⇔ 171	VZ111	
		171,1 ⇔ 203	VZ112	
		203,1 ⇔ 235	VZ113	
		235,1 ⇔ 277	VZ114	
		277,1 ⇔ 314	VZ115	
		314,1 ⇔ 350	VZ116	
		350,1 ⇔ 381	VZ117	
		381,1 ⇔ 423,2	VZ118	
		 <p>Maniglie posizionabili liberamente in altezza Handles which can be positioned freely in height</p>	73,7 ↓ 110,4	110,4 ⇔ 140
140,1 ⇔ 171	VZ211			
171,1 ⇔ 203	VZ212			
203,1 ⇔ 235	VZ213			
235,1 ⇔ 277	VZ214			
277,1 ⇔ 314	VZ215			
314,1 ⇔ 350	VZ216			
350,1 ⇔ 381	VZ217			
381,1 ⇔ 423,2	VZ218			
 <p>Maniglie posizionabili liberamente in altezza Handles which can be positioned freely in height</p>	110,5 ↓ 147,2			110,4 ⇔ 140
		140,1 ⇔ 171	VZ311	
		171,1 ⇔ 203	VZ312	
		203,1 ⇔ 235	VZ313	
		235,1 ⇔ 277	VZ314	
		277,1 ⇔ 314	VZ315	
		314,1 ⇔ 350	VZ316	
		350,1 ⇔ 381	VZ317	
		381,1 ⇔ 423,2	VZ318	
		 <p>Maniglie posizionabili liberamente in altezza Handles which can be positioned freely in height</p>	147,3 ↓ 184	110,4 ⇔ 140
140,1 ⇔ 171	VZ411			
171,1 ⇔ 203	VZ412			
203,1 ⇔ 235	VZ413			
235,1 ⇔ 277	VZ414			
277,1 ⇔ 314	VZ415			
314,1 ⇔ 350	VZ416			
350,1 ⇔ 381	VZ417			
381,1 ⇔ 423,2	VZ418			

TESSUTO E BINARI//FABRIC AND RAILS

Il prezzo include:

- un frontale in tessuto;
- binari e meccanismi di scorrimento;
- profili verticali (maniglioni);

Vedi ricambio tessuto a pag. 284

The price includes:

- one fabric front;
- Rails and sliding mechanisms;
- vertical edges (handles);

See replacement fabric on page 284

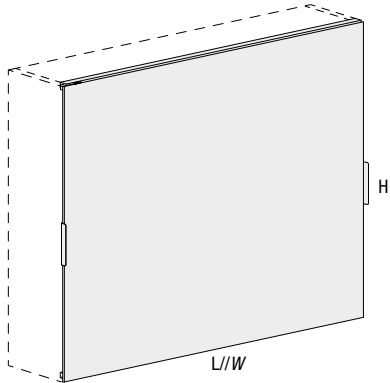
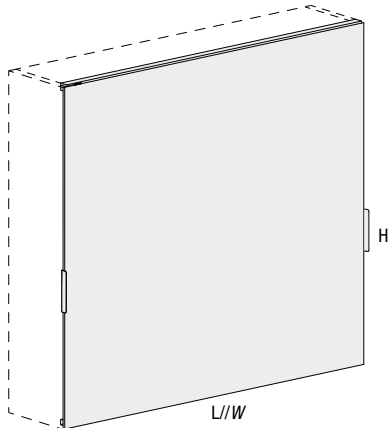
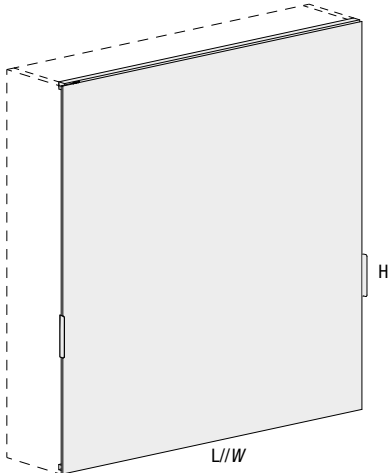
Descrizione/Description	Da H a H From H to H	Da L a L From W to W	Codice Code	Tessuto Fabric
 <p>Maniglie posizionabili liberamente in altezza Handles which can be positioned freely in height</p>	184,1 ↓ 227	128,8 ⇄ 140	VZ510	
		140,1 ⇄ 171	VZ511	
		171,1 ⇄ 203	VZ512	
		203,1 ⇄ 235	VZ513	
		235,1 ⇄ 277	VZ514	
		277,1 ⇄ 314	VZ515	
		314,1 ⇄ 350	VZ516	
		350,1 ⇄ 381	VZ517	
		381,1 ⇄ 423,2	VZ518	
		 <p>Maniglie posizionabili liberamente in altezza Handles which can be positioned freely in height</p>	227,1 ↓ 265	128,8 ⇄ 140
140,1 ⇄ 171	VZ611			
171,1 ⇄ 203	VZ612			
203,1 ⇄ 235	VZ613			
235,1 ⇄ 277	VZ614			
277,1 ⇄ 314	VZ615			
314,1 ⇄ 350	VZ616			
350,1 ⇄ 381	VZ617			
381,1 ⇄ 423,2	VZ618			
 <p>Maniglie posizionabili liberamente in altezza Handles which can be positioned freely in height</p>	265,1 ↓ 270			128,8 ⇄ 140
		140,1 ⇄ 171	VZ711	
		171,1 ⇄ 203	VZ712	
		203,1 ⇄ 235	VZ713	
		235,1 ⇄ 277	VZ714	
		277,1 ⇄ 314	VZ715	
		314,1 ⇄ 350	VZ716	
		350,1 ⇄ 381	VZ717	
		381,1 ⇄ 423,2	VZ718	

**Accessori interni e
personalizzazioni**
*Internal accessories and
customisation*

PERSONALIZZAZIONE SCHIENE//BACK PANEL CUSTOMISATION

La struttura e gli accessori interni sono tutti in colore pomice.

Su richiesta sono disponibili, allo stesso prezzo, schiene in nobilitato perla, lino o rovere Fineline.

The structure and internal accessories are all in pomice.

On request, back panels are available in perla, lino or Fineline oak melamine, at the same price.

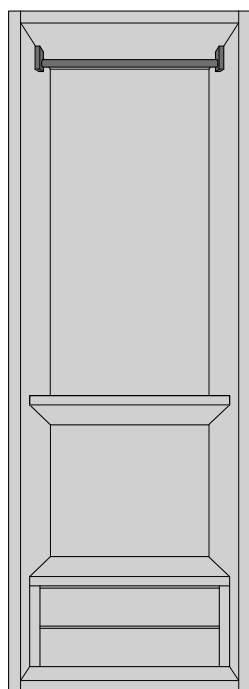

Pomice

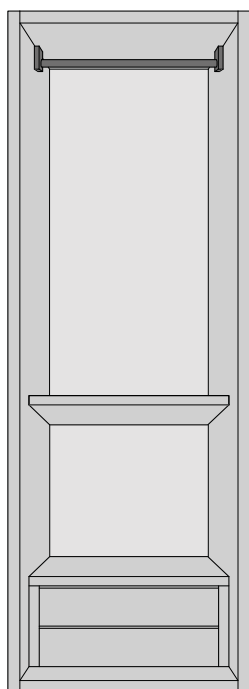

Perla

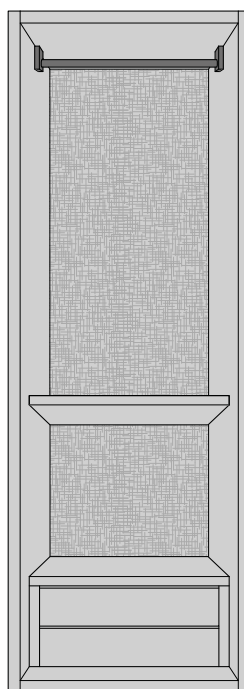

Lino

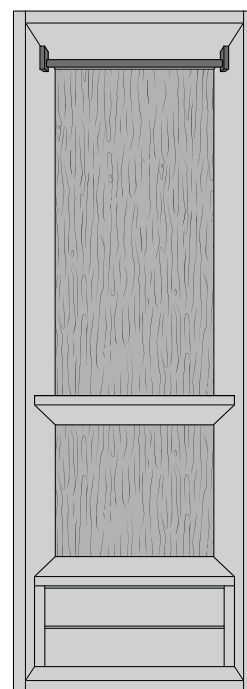

Rovere Fineline//Fineline oak











MAGGIORAZIONE PER SCHIENE STAMPATE CON MATERIALI XGLASS//EXTRA COST FOR BACK PANELS PRINTED WITH XGLASS MATERIALS







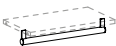

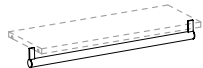
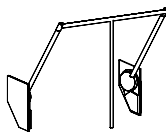
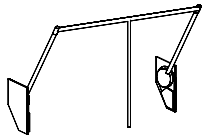



È possibile personalizzare le schiene stampando i pannelli nobilitati con i materiali della collezione XGlass (ad esclusione dei metalli), con maggiorazione di prezzo.

The backs can be personalised by printing the melamine panels with materials from the XGlass collection (excluding metals). Extra costs apply.

		Altezza colonna Tall unit height								
		Larghezza colonna Tall unit width		73,6	110,4	147,2	184	227	243	265
		43,5								
		47,5								
		68,5								
		89,5								
		97,5								
		99,5								
	112,5									



ACCESSORI PER ET VOILÀ STRUTTURA A VANI//ACCESSORIES FOR ET VOILÀ STRUCTURE WITH COMPARTMENTS

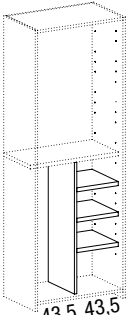
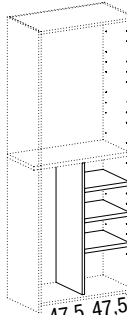
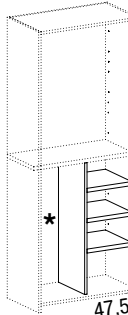
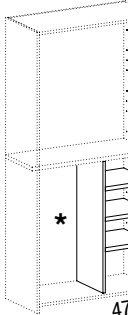
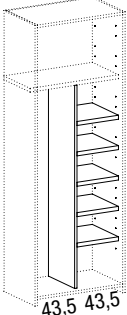
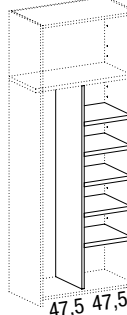
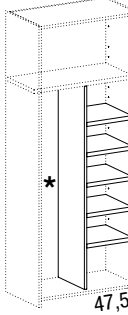
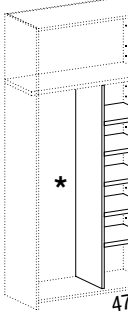
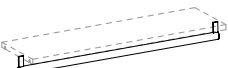
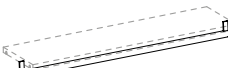
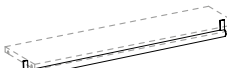
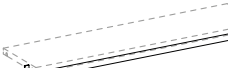
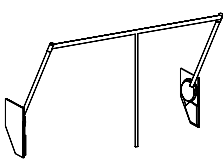
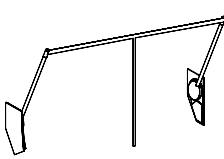
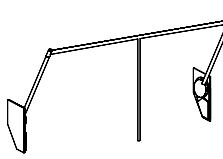
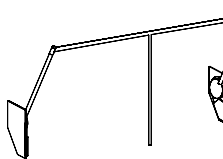

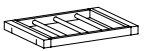
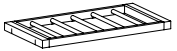
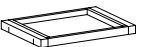

		Larghezza Width	43,5	47,5	68,5
RIPIANO LEGNO (SP. 3,8 cm) Prevedere almeno un ripiano in legno. Vedi pag.259 WOODEN SHELF (3,8 cm THICK) Consider at least one wooden shelf. See page.259					
P armadio wardrobe D.	P accessori D. accessories		P22030	P22031	P22032
53	43,8	Nobilitato//Melamine finished			
65,4	48,7	Nobilitato//Melamine finished	P22001	P22002	P22003
RIPIANO VETRO (SP. 1 cm) GLASS SHELF (1 cm THICK)					
P armadio wardrobe D.	P accessori D. accessories		D26015	D26016	D26017
53	43,8	Vetro trasparente//Clear glass Vetro fumè//Smoked glass			
65,4	48,7	Vetro trasparente//Clear glass Vetro fumè//Smoked glass	D26001	D26002	D26003
PORTASCARPE SHOE RACK					
P armadio wardrobe D.	P accessori D. accessories		D33001	D33002	D33003
65,4	48,7	Nobilitato//Melamine finished			
DIVISORIO CON RIPIANI Altezza 125,3 Per colonne H min. 184 cm PARTITION WITH SHELVES height 125.3 For compartment units, min. H 184 cm					
P armadio wardrobe D.	P accessori D. accessories				
65,4	48,7	Nobilitato//Melamine finished			
DIVISORIO CON RIPIANI Altezza 192,5 PARTITION WITH SHELVES height 192.5					
P armadio wardrobe D.	P accessori D. accessories				
65,4	48,7	Nobilitato//Melamine finished			
ASTA APPENDIABILI CLOTHES HANGING ROD					
Acciaio verniciato//Painted steel			D28001	D28002	D28003
SERVETTO H. 91 PULL-DOWN HANGING ROD H. 91					
Alluminio//Aluminium				D27001	D27002

89,5	97,5	99,5	112,5
			
P22033	P22034	P22035	P22036
P22004	P22005	P22006	P22007
			
D26018	D26019	D26020	D26021
D26004	D26005	D26006	D26007
			
D33004	D33005	D33006	D33007
			
43,5 43,5	47,5 47,5	47,5	47,5
D29A01	D29A11	D29A11	D29A11
			
43,5 43,5	47,5 47,5	47,5	47,5
D29B01	D29B11	D29B11	D29B11
			
D28004	D28005	D28006	D28007
			
D27003	D27004	D27005	D27006

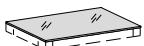
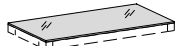
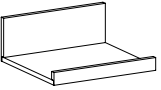
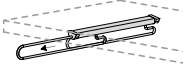
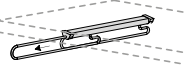
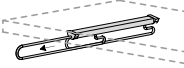
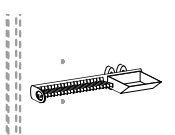
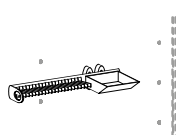
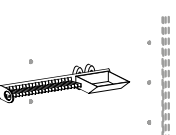
* Asta appendiabiti su misura
 * Customised clothes hanging rod

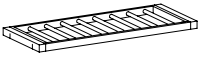
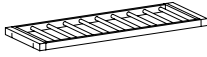
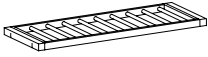
Su richiesta foratura per accessori interni solo dove previsti nell'ordine, senza sovrapprezzo.
 Upon request, holes for internal accessories to be only where specified on the order, at no extra cost.

			Larghezza Width	43,5	47,5	68,5
VASSOIO ESTRAIBILE CON PORTA PANTALONI PULL-OUT TRAY WITH TROUSER HOLDER P armadio wardrobe D. P accessori D. accessories 65,4 48,7 Nobilitato//Melamine finished						
				D22001		D22002
VASSOIO ESTRAIBILE PULL-OUT TRAY P armadio wardrobe D. P accessori D. accessories 65,4 48,7 Nobilitato//Melamine finished						
				D23001		D23002
COPERCHIO VETRO FUMÈ PER VASSOIO ESTRAIBILE E VASSOIO ESTRAIBILE CON PORTA PANTALONI SMOKED GLASS TOP FOR PULL-OUT TRAY AND PULL-OUT TRAY WITH TROUSER RACK P armadio wardrobe D. P accessori D. accessories 65,4 48,7 Nobilitato//Melamine finished						
				P31001		P31002
RIPIANO ESTRAIBILE Include il ripiano estraibile sp. 3,8 cm e un ripiano superiore fisso con profondità dedicata (vedi pag. 251) PULL-OUT SHELF Includes pull-out shelf, 3,8 cm thick, and a fixed top shelf with specific depth (see page. 251) P armadio wardrobe D. P accessori D. accessories 65,4 48,7 Nobilitato//Melamine finished						
TOP IN VETRO OPZIONALE PER RIPIANO ESTRAIBILE OPTIONAL GLASS TOP FOR PULL-OUT SHELF Codice//Code						
Vetro lucido//Polished glass						
Vetro opaco//Matt glass						
XGlass						
VASSOIO ESTRAIBILE SUL FONDO PULL-OUT TRAY ON THE BASE P armadio wardrobe D. P accessori D. accessories 65,4 48,7 Nobilitato//Melamine finished						
						D25001
APPENDIABITI ESTRAIBILE 29 cm chiuso/43 cm aperto PULL-OUT CLOTHES STAND 29 cm closed/43 cm open Alluminio//Aluminium						
			D30001	D30001		D30001
PORTACRAVATTE E PORTA CINTURE ESTRAIBILE 20 posti per cravatte - L. 50,5 cm PULL-OUT TIE HOLDER AND BELT HOLDER 20 spaces for ties - W. 50.5 cm Alluminio//Aluminium						
			D31001	D31001		D31001

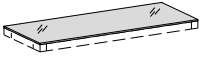
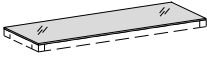
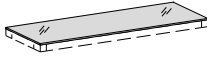
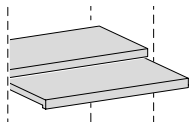
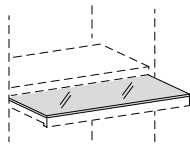
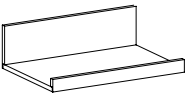
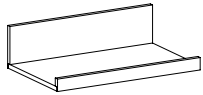
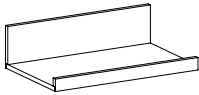
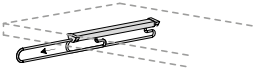
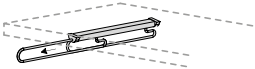
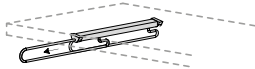
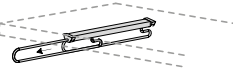
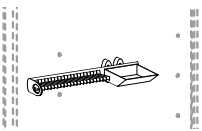
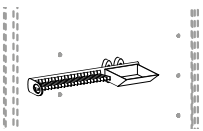
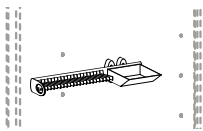
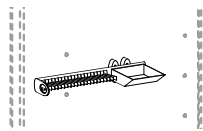
89,5	97,5	99,5	112,5
			
D22003	D22004	D22005	
			
D23003	D23004	D23005	
			
P31003	P31004	P31005	
			
	P32001		
			
	P33001		
			
D25002	D25003	D25004	
			
D30001	D30001	D30001	D30001
			
D31001	D31001	D31001	D31001

ILLUMINAZIONE A LED CON SENSORE 3000°K PER FIANCO

Alimentatore escluso
 *Prevedere fondo di finitura per armadi con struttura a vani sospesi visibili da sotto

LED LIGHTING WITH 3000°K SENSOR FOR SIDE PANEL

Power unit excluded
 *Consider a finishing bottom for wall-mounted wardrobes with compartment structure that are visible from below

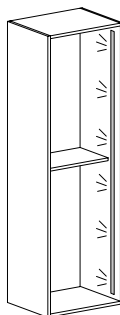

Altezza//Height	73,6*	110,4*	147,2*	184*	227	243	265	290
Codice//Code	D20055	D20051	D20047	D20048	D20034	D20035	D20036	D20037
1 LED								
Watt	8,4	12,6	16,8	21	25,9	27,7	30,2	33,1
Codice//Code	D20056	D20053	D20049	D20050	D20039	D20040	D20041	D20042
2 LED								

**ALIMENTATORE 24 V, 4 USCITE, 100 WATT MAX 3 LED
 24 V POWER SUPPLY, 4 OUTPUTS, 100 WATT MAX 3 LED**



D20038

Indicare la posizione del LED (fianco destro o sinistro). Non è possibile applicare 2 LED sullo stesso fianco.
 Specify the position of the LEDs (left or right-hand side panel). 2 LEDs cannot be applied to the same side panel.

CASSETTIERE//DRAWER UNITS

Cassettiere utilizzabili per:
- et voilà struttura a vani

Drawer units usable for:
- et voilà compartment structure

APERTURE//OPENING MECHANISMS

Attenzione: non è possibile avere cassettiere con aperture miste (push-pull e a tirare).
Note: drawer units cannot feature a mixture of opening mechanisms (push-pull and pull).

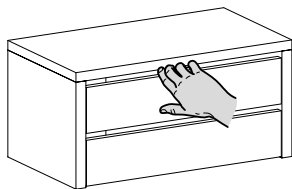

APERTURA A TIRARE
PULL OPENING

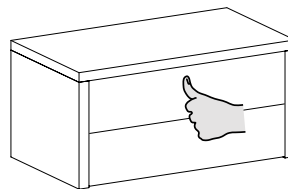

APERTURA PUSH-PULL
PUSH-PULL OPENING

TIPOLOGIE FRONTALI//TYPES OF FRONT

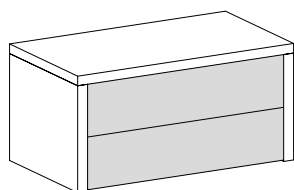

Nobilitato
Melamine

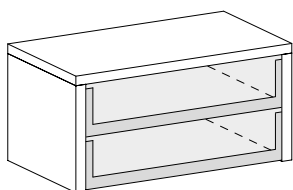

Vetro fumè
Smoked glass

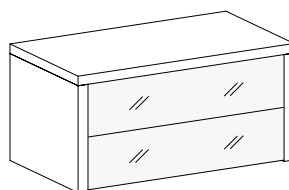

Vetro lucido o opaco
Polished or matt glass front

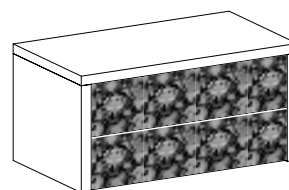

Vetro XGlass
XGlass glass

TOP

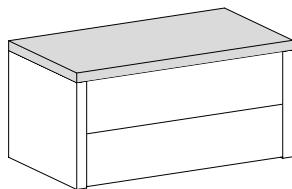

I prezzi delle cassettiere sono con top standard in nobilitato.
The price of the drawer units includes a standard melamine top.

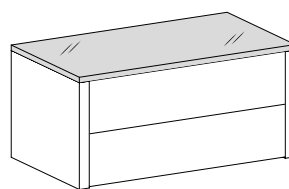

Per top in vetro (fumè, lucido, opaco o XGlass) vedere pagina optional.
For glass tops (smoked, polished, matt or XGlass), please see the optionals page.









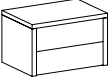

P. 43,8 CASSETTIERE PER ARMADI P. 53//D 43,8 DRAWER UNITS FOR WARDROBES D 53

Larghezza Width	68,5	89,5	97,5			
ALTEZZA 42,7 HEIGHT 42,7 2 CASSETTI H 19,2 2 DRAWERS H 19,2						
	A TIRARE//PULL-OUT DA0082	PUSH-PULL DB0082	A TIRARE//PULL-OUT DA0083	PUSH-PULL DB0083	A TIRARE//PULL-OUT DA0084	PUSH-PULL DB0084
	Codice//Code		Codice//Code		Codice//Code	
	Nobilitato//Melamine finished		Nobilitato//Melamine finished		Nobilitato//Melamine finished	
	Vetro fumè//Smoked glass		Vetro fumè//Smoked glass		Vetro fumè//Smoked glass	
	Vetro lucido//Polished glass		Vetro lucido//Polished glass		Vetro lucido//Polished glass	
	Vetro opaco//Matt glass		Vetro opaco//Matt glass		Vetro opaco//Matt glass	
XGlass		XGlass		XGlass		
ALTEZZA 61,9 HEIGHT 61,9 3 CASSETTI H 19,2 3 DRAWERS H 19,2						
	A TIRARE//PULL-OUT DA0085	PUSH-PULL DB0085	A TIRARE//PULL-OUT DA0086	PUSH-PULL DB0086	A TIRARE//PULL-OUT DA0087	PUSH-PULL DB0087
	Codice//Code		Codice//Code		Codice//Code	
	Nobilitato//Melamine finished		Nobilitato//Melamine finished		Nobilitato//Melamine finished	
	Vetro fumè//Smoked glass		Vetro fumè//Smoked glass		Vetro fumè//Smoked glass	
	Vetro lucido//Polished glass		Vetro lucido//Polished glass		Vetro lucido//Polished glass	
	Vetro opaco//Matt glass		Vetro opaco//Matt glass		Vetro opaco//Matt glass	
XGlass		XGlass		XGlass		
ALTEZZA 61,9 HEIGHT 61,9 4 CASSETTI H 14,4 4 DRAWERS H 14,4						
	A TIRARE//PULL-OUT DA0088	PUSH-PULL DB0088	A TIRARE//PULL-OUT DA0089	PUSH-PULL DB0089	A TIRARE//PULL-OUT DA0090	PUSH-PULL DB0090
	Codice//Code		Codice//Code		Codice//Code	
	Nobilitato//Melamine finished		Nobilitato//Melamine finished		Nobilitato//Melamine finished	
	Vetro fumè//Smoked glass		Vetro fumè//Smoked glass		Vetro fumè//Smoked glass	
	Vetro lucido//Polished glass		Vetro lucido//Polished glass		Vetro lucido//Polished glass	
	Vetro opaco//Matt glass		Vetro opaco//Matt glass		Vetro opaco//Matt glass	
XGlass		XGlass		XGlass		
ALTEZZA 81,1 HEIGHT 81,1 4 CASSETTI H 19,2 4 DRAWERS H 19,2						
	A TIRARE//PULL-OUT DA0091	PUSH-PULL DB0091	A TIRARE//PULL-OUT DA0092	PUSH-PULL DB0092	A TIRARE//PULL-OUT DA0093	PUSH-PULL DB0093
	Codice//Code		Codice//Code		Codice//Code	
	Nobilitato//Melamine finished		Nobilitato//Melamine finished		Nobilitato//Melamine finished	
	Vetro fumè//Smoked glass		Vetro fumè//Smoked glass		Vetro fumè//Smoked glass	
	Vetro lucido//Polished glass		Vetro lucido//Polished glass		Vetro lucido//Polished glass	
	Vetro opaco//Matt glass		Vetro opaco//Matt glass		Vetro opaco//Matt glass	
XGlass		XGlass		XGlass		
ALTEZZA 100,3 HEIGHT 100,3 5 CASSETTI H 19,2 5 DRAWERS H 19,2						
	A TIRARE//PULL-OUT DA0094	PUSH-PULL DB0094	A TIRARE//PULL-OUT DA0095	PUSH-PULL DB0095	A TIRARE//PULL-OUT DA0096	PUSH-PULL DB0096
	Codice//Code		Codice//Code		Codice//Code	
	Nobilitato//Melamine finished		Nobilitato//Melamine finished		Nobilitato//Melamine finished	
	Vetro fumè//Smoked glass		Vetro fumè//Smoked glass		Vetro fumè//Smoked glass	
	Vetro lucido//Polished glass		Vetro lucido//Polished glass		Vetro lucido//Polished glass	
	Vetro opaco//Matt glass		Vetro opaco//Matt glass		Vetro opaco//Matt glass	
XGlass		XGlass		XGlass		

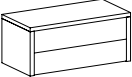
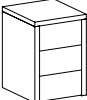
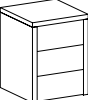
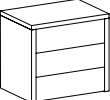
P. 43,8 CASSETTIERE PER ARMADI P. 53//D 43,8 DRAWER UNITS FOR WARDROBES D 53

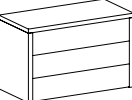
Larghezza Width	68,5	89,5	97,5			
ALTEZZA 100,3 HEIGHT 100,3 4 CASSETTI H 14,4 + 2 CASSETTI H 19,2 4 DRAWERS H 14,4 + 2 DRAWERS H 19,2						
	A TIRARE//PULL-OUT DA0097	PUSH-PULL DB0097	A TIRARE//PULL-OUT DA0098	PUSH-PULL DB0098	A TIRARE//PULL-OUT DA0099	PUSH-PULL DB0099
	Nobilitato//Melamine finished					
	Vetro fumè//Smoked glass					
	Vetro lucido//Polished glass					
	Vetro opaco//Matt glass					
XGlass						
ALTEZZA 119,5 HEIGHT 119,5 6 CASSETTI H 19,2 6 DRAWERS H 19,2						
	A TIRARE//PULL-OUT DA0100	PUSH-PULL DB0100	A TIRARE//PULL-OUT DA0101	PUSH-PULL DB0101	A TIRARE//PULL-OUT DA0102	PUSH-PULL DB0102
	Nobilitato//Melamine finished					
	Vetro fumè//Smoked glass					
	Vetro lucido//Polished glass					
	Vetro opaco//Matt glass					
XGlass						
ALTEZZA 119,5 HEIGHT 119,5 8 CASSETTI H 14,4 8 DRAWERS H 14,4						
	A TIRARE//PULL-OUT DA0103	PUSH-PULL DB0103	A TIRARE//PULL-OUT DA0104	PUSH-PULL DB0104	A TIRARE//PULL-OUT DA0105	PUSH-PULL DB0105
	Nobilitato//Melamine finished					
	Vetro fumè//Smoked glass					
	Vetro lucido//Polished glass					
	Vetro opaco//Matt glass					
XGlass						
ALTEZZA 119,5 HEIGHT 119,5 4 CASSETTI H 14,4 + 3 CASSETTI H 19,2 4 DRAWERS H 14,4 + 3 DRAWERS H 19,2						
	A TIRARE//PULL-OUT DA0106	PUSH-PULL DB0106	A TIRARE//PULL-OUT DA0107	PUSH-PULL DB0107	A TIRARE//PULL-OUT DA0108	PUSH-PULL DB0108
	Nobilitato//Melamine finished					
	Vetro fumè//Smoked glass					
	Vetro lucido//Polished glass					
	Vetro opaco//Matt glass					
XGlass						

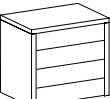
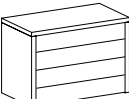
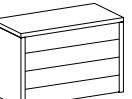
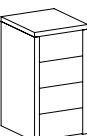
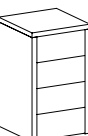
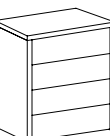
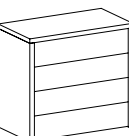
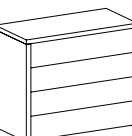
P. 48,7 CASSETTIERE PER ARMADI P. 65,4//D 48,7 DRAWER UNITS FOR WARDROBES D 65,4

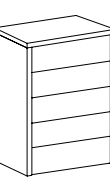
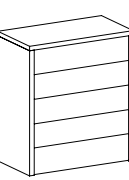
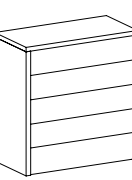
Larghezza Width	43,5	47,5	68,5	89,5	97,5					
ALTEZZA 42,7 HEIGHT 42,7 2 CASSETTI H 19,2 2 DRAWERS H 19,2										
	A TIRARE//PULL-OUT DA0001	PUSH-PULL DB0001	A TIRARE//PULL-OUT DA0002	PUSH-PULL DB0002	A TIRARE//PULL-OUT DA0003	PUSH-PULL DB0003	A TIRARE//PULL-OUT DA0004	PUSH-PULL DB0004	A TIRARE//PULL-OUT DA0005	PUSH-PULL DB0005
	Codice//Code									
	Nobilitato//Melamine finished									
	Vetro fumè//Smoked glass									
	Vetro lucido//Polished glass									
	Vetro opaco//Matt glass									
XGlass										
ALTEZZA 61,9 HEIGHT 61,9 3 CASSETTI H 19,2 3 DRAWERS H 19,2										
	A TIRARE//PULL-OUT DA0010	PUSH-PULL DB0010	A TIRARE//PULL-OUT DA0011	PUSH-PULL DB0011	A TIRARE//PULL-OUT DA0012	PUSH-PULL DB0012	A TIRARE//PULL-OUT DA0013	PUSH-PULL DB0013	A TIRARE//PULL-OUT DA0014	PUSH-PULL DB0014
	Codice//Code									
	Nobilitato//Melamine finished									
	Vetro fumè//Smoked glass									
	Vetro lucido//Polished glass									
	Vetro opaco//Matt glass									
XGlass										
ALTEZZA 61,9 HEIGHT 61,9 4 CASSETTI H 14,4 4 DRAWERS H 14,4										
	A TIRARE//PULL-OUT DA0019	PUSH-PULL DB0019	A TIRARE//PULL-OUT DA0020	PUSH-PULL DB0020	A TIRARE//PULL-OUT DA0021	PUSH-PULL DB0021	A TIRARE//PULL-OUT DA0022	PUSH-PULL DB0022	A TIRARE//PULL-OUT DA0023	PUSH-PULL DB0023
	Codice//Code									
	Nobilitato//Melamine finished									
	Vetro fumè//Smoked glass									
	Vetro lucido//Polished glass									
	Vetro opaco//Matt glass									
XGlass										
ALTEZZA 81,1 HEIGHT 81,1 4 CASSETTI H 19,2 4 DRAWERS H 19,2										
	A TIRARE//PULL-OUT DA0028	PUSH-PULL DB0028	A TIRARE//PULL-OUT DA0029	PUSH-PULL DB0029	A TIRARE//PULL-OUT DA0030	PUSH-PULL DB0030	A TIRARE//PULL-OUT DA0031	PUSH-PULL DB0031	A TIRARE//PULL-OUT DA0032	PUSH-PULL DB0032
	Codice//Code									
	Nobilitato//Melamine finished									
	Vetro fumè//Smoked glass									
	Vetro lucido//Polished glass									
	Vetro opaco//Matt glass									
XGlass										
ALTEZZA 100,3 HEIGHT 100,3 5 CASSETTI H 19,2 5 DRAWERS H 19,2										
	A TIRARE//PULL-OUT DA0037	PUSH-PULL DB0037	A TIRARE//PULL-OUT DA0038	PUSH-PULL DB0038	A TIRARE//PULL-OUT DA0039	PUSH-PULL DB0039	A TIRARE//PULL-OUT DA0040	PUSH-PULL DB0040	A TIRARE//PULL-OUT DA0041	PUSH-PULL DB0041
	Codice//Code									
	Nobilitato//Melamine finished									
	Vetro fumè//Smoked glass									
	Vetro lucido//Polished glass									
	Vetro opaco//Matt glass									
XGlass										

99,5

112,5

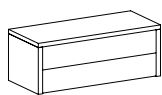
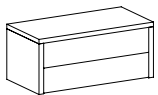

A TIRARE//PULL-OUT
DA0006

PUSH-PULL
DB0006

A TIRARE//PULL-OUT
DA0007

PUSH-PULL
DB0007

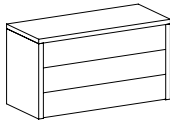
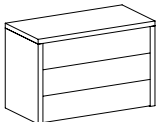

A TIRARE//PULL-OUT
DA0015

PUSH-PULL
DB0015

A TIRARE//PULL-OUT
DA0016

PUSH-PULL
DB0016

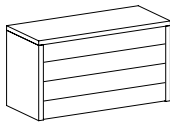
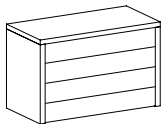

A TIRARE//PULL-OUT
DA0024

PUSH-PULL
DB0024

A TIRARE//PULL-OUT
DA0025

PUSH-PULL
DB0025

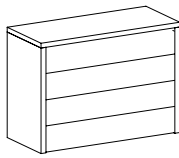
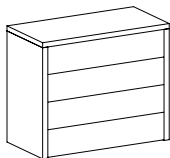

A TIRARE//PULL-OUT
DA0033

PUSH-PULL
DB0033

A TIRARE//PULL-OUT
DA0034

PUSH-PULL
DB0034

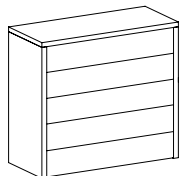
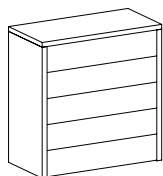





A TIRARE//PULL-OUT
DA0042

PUSH-PULL
DB0042

A TIRARE//PULL-OUT
DA0043

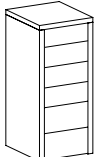
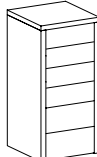
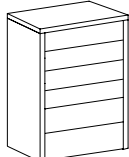
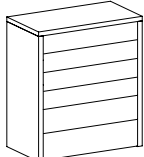
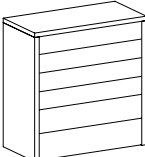
PUSH-PULL
DB0043

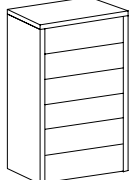
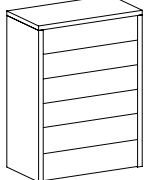
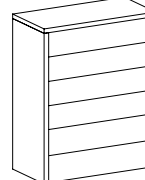
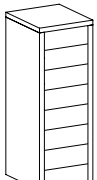
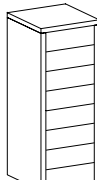
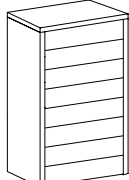
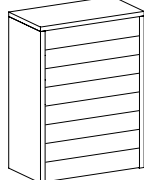
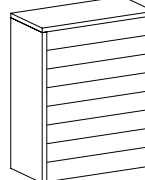
P. 48,7 CASSETTIERE PER ARMADI P. 65,4//D 48,7 DRAWER UNITS FOR WARDROBES D 65,4

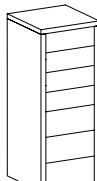
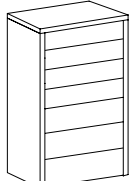
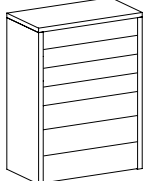
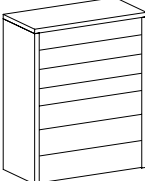
Larghezza Width	43,5	47,5	68,5	89,5	97,5					
ALTEZZA 100,3 HEIGHT 100,3 4 CASSETTI H 14,4 + 2 CASSETTI H 19,2 4 DRAWERS H 14,4 + 2 DRAWERS H 19,2										
	A TIRARE//PULL-OUT DA0046	PUSH-PULL DB0046	A TIRARE//PULL-OUT DA0047	PUSH-PULL DB0047	A TIRARE//PULL-OUT DA0048	PUSH-PULL DB0048	A TIRARE//PULL-OUT DA0049	PUSH-PULL DB0049	A TIRARE//PULL-OUT DA0050	PUSH-PULL DB0050
	Codice//Code									
	Nobilitato//Melamine finished									
	Vetro fumè//Smoked glass									
	Vetro lucido//Polished glass									
	Vetro opaco//Matt glass									
XGlass										
ALTEZZA 119,5 HEIGHT 119,5 6 CASSETTI H 19,2 6 DRAWERS H 19,2										
	A TIRARE//PULL-OUT DA0055	PUSH-PULL DB0055	A TIRARE//PULL-OUT DA0056	PUSH-PULL DB0056	A TIRARE//PULL-OUT DA0057	PUSH-PULL DB0057	A TIRARE//PULL-OUT DA0058	PUSH-PULL DB0058	A TIRARE//PULL-OUT DA0059	PUSH-PULL DB0059
	Codice//Code									
	Nobilitato//Melamine finished									
	Vetro fumè//Smoked glass									
	Vetro lucido//Polished glass									
	Vetro opaco//Matt glass									
XGlass										
ALTEZZA 119,5 HEIGHT 119,5 8 CASSETTI H 14,4 8 DRAWERS H 14,4										
	A TIRARE//PULL-OUT DA0064	PUSH-PULL DB0064	A TIRARE//PULL-OUT DA0065	PUSH-PULL DB0065	A TIRARE//PULL-OUT DA0066	PUSH-PULL DB0066	A TIRARE//PULL-OUT DA0067	PUSH-PULL DB0067	A TIRARE//PULL-OUT DA0068	PUSH-PULL DB0068
	Codice//Code									
	Nobilitato//Melamine finished									
	Vetro fumè//Smoked glass									
	Vetro lucido//Polished glass									
	Vetro opaco//Matt glass									
XGlass										
ALTEZZA 119,5 HEIGHT 119,5 4 CASSETTI H 14,4 + 3 CASSETTI H 19,2 4 DRAWERS H 14,4 + 3 DRAWERS H 19,2										
	A TIRARE//PULL-OUT DA0073	PUSH-PULL DB0073	A TIRARE//PULL-OUT DA0074	PUSH-PULL DB0074	A TIRARE//PULL-OUT DA0075	PUSH-PULL DB0075	A TIRARE//PULL-OUT DA0076	PUSH-PULL DB0076	A TIRARE//PULL-OUT DA0077	PUSH-PULL DB0077
	Codice//Code									
	Nobilitato//Melamine finished									
	Vetro fumè//Smoked glass									
	Vetro lucido//Polished glass									
	Vetro opaco//Matt glass									
XGlass										

99,5

112,5

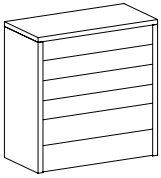

A TIRARE//PULL-OUT
DA0051

PUSH-PULL
DB0051

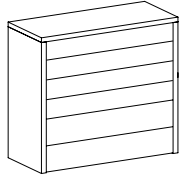

A TIRARE//PULL-OUT
DA0052

PUSH-PULL
DB0052

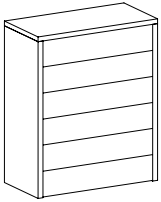

A TIRARE//PULL-OUT
DA0060

PUSH-PULL
DB0060

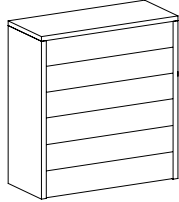

A TIRARE//PULL-OUT
DA0061

PUSH-PULL
DB0061

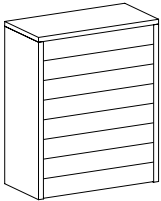

A TIRARE//PULL-OUT
DA0069

PUSH-PULL
DB0069

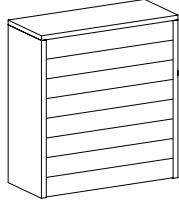

A TIRARE//PULL-OUT
DA0070

PUSH-PULL
DB0070

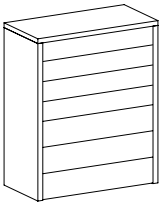

A TIRARE//PULL-OUT
DA0078

PUSH-PULL
DB0078

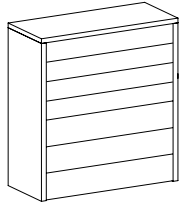

A TIRARE//PULL-OUT
DA0079

PUSH-PULL
DB0079

OPTIONAL CASSETTIERE//DRAWER UNIT OPTIONALS

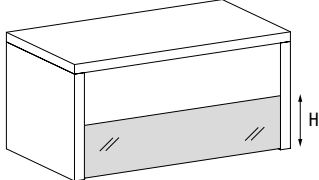
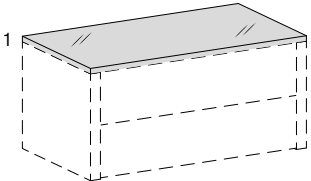
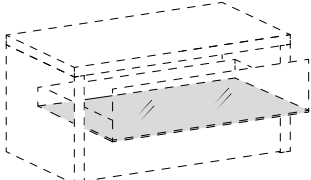
Descrizione//Description	H	Larghezza Width	Nobilitato Melamine	Vetro fumè Smoked glass	Vetro lucido Polished glass	Vetro opaco Matt glass	XGlass
<p>Cassettiere con frontali misti Per cassettiere con frontali misti, calcolare la differenza di prezzo sostituendo il valore del frontale del singolo cassetto. Attenzione: non è possibile avere cassettiere con aperture miste (push-pull e a tirare). Drawer units with mixed fronts For drawer units with mixed fronts, calculate the price difference by substituting the value of the front for the individual drawer. Note: drawer units cannot feature a mixture of opening mechanisms (push-pull and pull).</p> 	14,4	43,5					
		47,5					
		68,5					
		89,5					
		97,5					
		99,5					
		112,5					
	19,2	43,5					
		47,5					
		68,5					
		89,5					
		97,5					
		99,5					
		112,5					
<p>Top vetro Per cassettiere con top in vetro, partire dal prezzo di cassettiere con top in nobilitato e sostituire il prezzo del top in nobilitato con quello del top in vetro fumè, vetro lucido, vetro opaco o XGlass. Glass top For drawer units with a glass top, take the price of the drawer units with a melamine top and replace the price of the melamine top with the price of the smoked glass, polished glass, matt glass or XGlass top.</p> 		Larghezza Width	Nobilitato Melamine	Vetro fumè Smoked glass	Vetro lucido Polished glass	Vetro opaco Matt glass	XGlass
		43,5					
		47,5					
		68,5					
		89,5					
		97,5					
		99,5					
112,5							
<p>Fondi in vetro per interno cassetto Glass bottoms for drawer inside</p> 		Profondità Depth	Larghezza Width	Codice Code	Vetro lucido Polished glass	Vetro opaco Matt glass	XGlass
		43,8	68,5	F45009			
			89,5	F45010			
			97,5	F45011			
			43,5	F45001			
			47,5	F45002			
			68,5	F45004			
		48,7	89,5	F45005			
			97,5	F45006			
			99,5	F45007			
			112,5	F45008			

ACCESSORI//ACCESSORIES

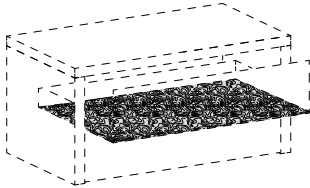
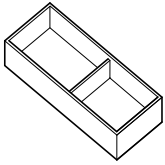
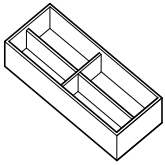
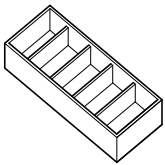
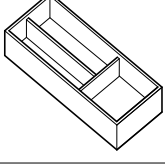
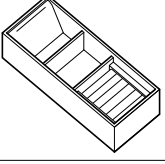
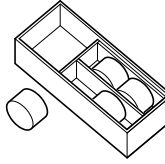
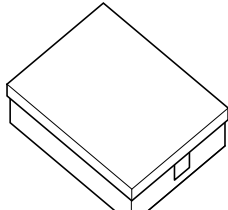
Descrizione//Description	Larghezza Width			Codice Code	Ecopelle* Faux leather*
Fondi in ecopelle per interno cassetto <i>Faux leather bottoms for drawer inside</i> 	43,5 47,5 68,5 89,5 97,5 99,5 112,5			D35001 D35009 D35011 D35012 D35013 D35014 D35015	
Vassoio multiuso con divisorio interno <i>Multi-purpose tray with internal divider</i> 	Altezza Height	Larghezza Width	Profondità Depth	Codice Code	Ecopelle* Faux leather*
Vassoio multiuso a 4 scomparti <i>Multi-purpose tray with 4 compartments</i> 	5	15	41	D35002	
Vassoio multiuso a 5 scomparti <i>Multi-purpose tray with 5 compartments</i> 	Altezza Height	Larghezza Width	Profondità Depth	Codice Code	Ecopelle* Faux leather*
Vassoio multiuso a 3 scomparti <i>Multi-purpose tray with 3 compartments</i> 	5	15	41	D35003	
Vassoio porta orecchini e anelli <i>Jewellery tray</i> 	Altezza Height	Larghezza Width	Profondità Depth	Codice Code	Ecopelle* Faux leather*
Vassoio portaorologi <i>Watch tray</i> 	5	15	41	D35004	
Contenitore rivestito in tessuto dotato di linguetta in eco-pelle. <i>Fabric storage unit with faux leather pull tab.</i> 	Altezza Height	Larghezza Width	Profondità Depth	Codice Code	Tessuto* Fabric*
	12,5	39	46,5	D35005	

* Disponibile nelle finiture Grigio Tasmania e Grigio Lino
 * Available in Grey Tasmania and Grey Lino

Riduzione in larghezza colonna
Tall unit width reduction

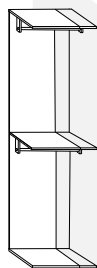

Riduzione colonna con attrezzatura standard

Colonna L min 15,8 cm
Colonna Weightless L min 28,2 cm
Column reduction with standard fittings
Column min. W 15,8 cm
Weightless column min. W 28,2 cm

Codice
Code

Maggiorazione
Extra Cost

RID0086

Per elementi aggiuntivi:
For additional elements:

Riduzione in larghezza asta appendiabiti
Clothes hanging rod width reduction

RID0087

Riduzione in larghezza ripiano
Shelf width reduction

RID0088

Riduzione in altezza colonna
Tall unit height reduction

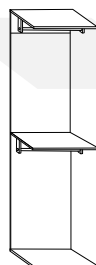

Riduzione colonna con attrezzatura standard

Colonna H min 100 cm
Colonna Weightless H min 42 cm
Column reduction with standard fittings
Column min. H 100 cm
Weightless column min. H 42 cm

RID0089

Riduzione in altezza fianco
Side panel height reduction

RID0090

Per elementi aggiuntivi:
For additional elements:

Maggiorazione per struttura fino a H 270 cm
Extra cost for structure up to H 270 cm

RID0104

Riduzione in profondità colonna
Tall unit depth reduction

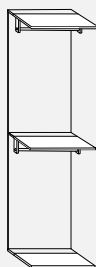

Riduzione colonna con attrezzatura standard

Colonna P min 19,2 cm
Column reduction with standard fittings
Column min. D 19,2 cm

RID0091

Riduzione in profondità fianco nobilitato/laccato
Melamine/lacquered side panel depth reduction

RID0092

Riduzione in profondità fianco tessuto
Fabric side panel depth reduction

RID0105

Previsto fissaggio a parete in caso di riduzione in profondità.
Where the depth is reduced, wall mounting is required.

Per elementi aggiuntivi:
For additional elements:

Riduzione in profondità ripiano
Shelf depth reduction

RID0093

Riduzione multipla di vani et voilà e cabine con attrezzatura standard in due o tre dimensioni (altezza, larghezza, profondità)
Multiple reduction of et voilà compartments and walk-in wardrobes with fittings in two or three sizes (height, width, depth)

RID0094

ET VOILÀ_WARDROBE - ACCESSORI PER STRUTTURA A VANI//ACCESSORIES FOR COMPARTMENT STRUCTURE

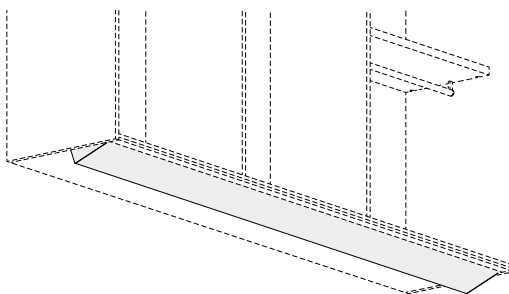
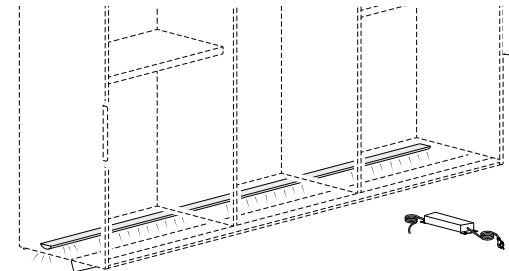
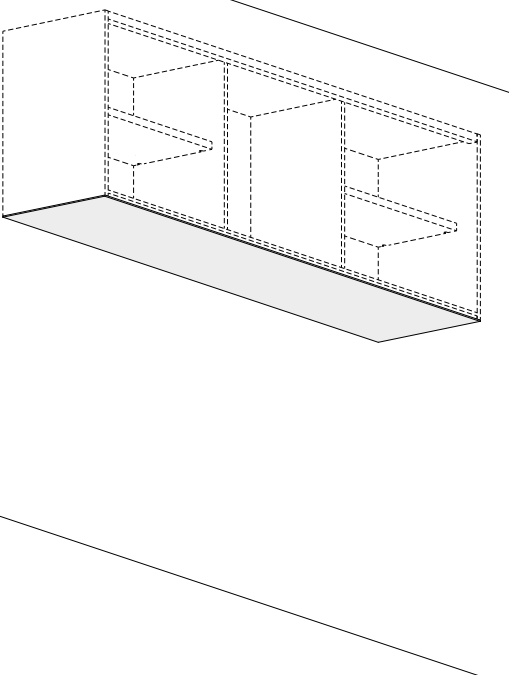
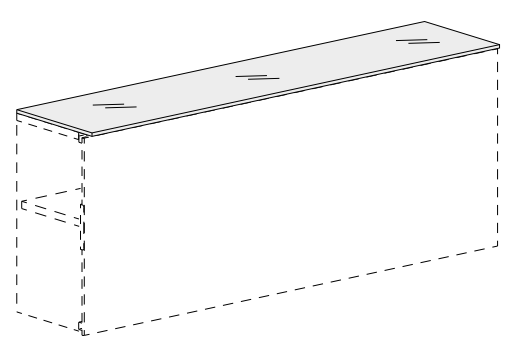
Descrizione/Description	Larghezza Width	Altezza Height	Profondità Depth	Codice Code	Laccato Lacquered	
Appendiabiti. Prezzi al metro lineare <i>Clotheshanger. Prices per meter</i> 	Max 417,4	7,2	21	VT0040		
Striscia LED adesiva 3200°K (220-240 V) senza interruttore. <i>3200°K LED adhesive strip (220-240 V) without a switch.</i> 	Larghezza Width	Potenza Power	Codice Code	LED		
Alimentatore 12 V, 6 uscite, max 30 Watt (non incluso) <i>Power supply 12 V, 6 exits, max 30 Watt (not included)</i>	200	12 W	VT0071			
	300	19 W	VT0072			
	410	27 W	VT0073			
	Alimentatore Power supply	30W	VT0074			
Pannello finitura fondo sp. 0,2 cm. Prezzi al metro lineare. <i>Bottom finish panel th. 0.2 cm. Prices per meter.</i> 	Larghezza Width	Profondità armadio Wardrobe depth	Codice Code	Laccato Lacquered		
Max 300	53	VT0080				
	65,4	VT0081				
Top vetro sp. 0,4 cm. Prezzi al metro lineare. Larghezza max 320 cm. <i>Glass top thk 0.4 cm. Prices per meter.</i> Max. width 320 cm. 	Larghezza Width	Profondità armadio Wardrobe depth	Codice Code	Vetro lucido Polished glass	Vetro opaco Matt glass	XGlass lucido o opaco Polished or matt XGlass
Max 320	53	VX310				
	65,4	VX320				

RICAMBIO TESSUTO//REPLACEMENT FABRIC

H	Da L a L From W to W	Codice Code	Ricambio tessuto Replacement fabric	Da H a H From H to H	Da L a L From W to W	Codice Code	Ricambio tessuto Replacement fabric
73,6	110,4 ⇨ 140	VS00110		184,1 ↓ 227	128,8 ⇨ 140	VS00510	
	140,1 ⇨ 171	VS00111			140,1 ⇨ 171	VS00511	
	171,1 ⇨ 203	VS00112			171,1 ⇨ 203	VS00512	
	203,1 ⇨ 235	VS00113			203,1 ⇨ 235	VS00513	
	235,1 ⇨ 277	VS00114			235,1 ⇨ 277	VS00514	
	277,1 ⇨ 314	VS00115			277,1 ⇨ 314	VS00515	
	314,1 ⇨ 350	VS00116			314,1 ⇨ 350	VS00516	
	350,1 ⇨ 381	VS00117			350,1 ⇨ 381	VS00517	
	381,1 ⇨ 423,2	VS00118			381,1 ⇨ 423,2	VS00518	
Da H a H From H to H	Da L a L From W to W	Codice Code	Ricambio tessuto Replacement fabric	Da H a H From H to H	Da L a L From W to W	Codice Code	Ricambio tessuto Replacement fabric
73,7 ↓ 110,4	110,4 ⇨ 140	VS00210		227,1 ↓ 265	128,8 ⇨ 140	VS00610	
	140,1 ⇨ 171	VS00211			140,1 ⇨ 171	VS00611	
	171,1 ⇨ 203	VS00212			171,1 ⇨ 203	VS00612	
	203,1 ⇨ 235	VS00213			203,1 ⇨ 235	VS00613	
	235,1 ⇨ 277	VS00214			235,1 ⇨ 277	VS00614	
	277,1 ⇨ 314	VS00215			277,1 ⇨ 314	VS00615	
	314,1 ⇨ 350	VS00216			314,1 ⇨ 350	VS00616	
	350,1 ⇨ 381	VS00217			350,1 ⇨ 381	VS00617	
	381,1 ⇨ 423,2	VS00218			381,1 ⇨ 423,2	VS00618	
Da H a H From H to H	Da L a L From W to W	Codice Code	Ricambio tessuto Replacement fabric	Da H a H From H to H	Da L a L From W to W	Codice Code	Ricambio tessuto Replacement fabric
110,5 ↓ 147,2	110,4 ⇨ 140	VS00310		265,1 ↓ 270	128,8 ⇨ 140	VS00710	
	140,1 ⇨ 171	VS00311			140,1 ⇨ 171	VS00711	
	171,1 ⇨ 203	VS00312			171,1 ⇨ 203	VS00712	
	203,1 ⇨ 235	VS00313			203,1 ⇨ 235	VS00713	
	235,1 ⇨ 277	VS00314			235,1 ⇨ 277	VS00714	
	277,1 ⇨ 314	VS00315			277,1 ⇨ 314	VS00715	
	314,1 ⇨ 350	VS00316			314,1 ⇨ 350	VS00716	
	350,1 ⇨ 381	VS00317			350,1 ⇨ 381	VS00717	
	381,1 ⇨ 423,2	VS00318			381,1 ⇨ 423,2	VS00718	
Da H a H From H to H	Da L a L From W to W	Codice Code	Ricambio tessuto Replacement fabric				
147,3 ↓ 184	110,4 ⇨ 140	VS00410					
	140,1 ⇨ 171	VS00411					
	171,1 ⇨ 203	VS00412					
	203,1 ⇨ 235	VS00413					
	235,1 ⇨ 277	VS00414					
	277,1 ⇨ 314	VS00415					
	314,1 ⇨ 350	VS00416					
	350,1 ⇨ 381	VS00417					
	381,1 ⇨ 423,2	VS00418					

RICAMBIO TESSUTO PER FIANCHI ESTERNI//REPLACEMENT FABRIC FOR EXTERNAL FABRIC

P fianco D side	H fianco H side	Codice Code	Ricambio tessuto Replacement fabric	P fianco D side	H fianco H side	Codice Code	Ricambio tessuto Replacement fabric
51,1	73,6	VR10201		63,5	73,6	VR10209	
	110,4	VR10202			110,4	VR10210	
	147,2	VR10203			147,2	VR10211	
	184	VR10204			184	VR10212	
	227	VR10205			227	VR10213	
	243	VR10206			243	VR10214	
	265	VR10207			265	VR10215	
	270	VR10208			270	VR10216	

INFORMAZIONI GENERALI GENERAL INFORMATION	Tutti i pannelli di particelle di legno nobilitati con carte melaminiche sono a bassa emissione di formaldeide e certificati Carb e TSCA title VI con bordi in ABS in tinta. Per la laccatura di pannelli e vetri vengono utilizzate solo vernici all'acqua. <i>All MDF panels are low formaldehyde CARB and TSCA Title VI certified, faced with melamine and with ABS edges in a matching colour. Only water-based paints are used on the panels and glass.</i>
STRUTTURA STRUCTURE	Pannello nobilitato spessore 2,5 cm. <i>Melamine panel 2,5 cm thick.</i>
FIANCO NOBILITATO MELAMINE SIDE PANEL	Pannello nobilitato spessore 2,5 cm. <i>Melamine panel 2,5 cm thick.</i>
FIANCO LACCATO LACQUERED SIDE PANEL	Pannello nobilitato spessore 2,5 cm, superfici esterne a vista laccate con vernici all'acqua. <i>Melamine panel 2,5 cm thick, external surfaces on show lacquered with water-based paints.</i>
FIANCO IN TESSUTO FABRIC SIDE	Lamiera di acciaio sp.0,1 cm rivestita in espanso sp.0,3 cm e tessuto, con sistema di aggancio al fianco in legno per renderlo sfoderabile. <i>Steel sheet metal 0,1 cm thick covered in foam 0,3 cm thick and fabric, with system for attaching to the wooden side panel so that it can be removed.</i>
RIPIANI LEGNO WOODEN SHELVES	Pannello nobilitato spessore 3,8 cm. <i>Melamine panel 3,8 cm thick.</i>
RIPIANI VETRO GLASS SHELVES	Vetro temperato spessore 1 cm. <i>Tempered glass 1 cm thick.</i>
BINARI DI SCORRIMENTO SLIDING RAILS	Alluminio verniciato a polveri epossidiche, con carrelli di scorrimento in lega di alluminio e particolari in nylon, meccanismo di chiusura magnetico integrato. <i>Aluminium painted with epoxy powder, with aluminium alloy runners and nylon components, built-in magnetic closing mechanism.</i>
PROFILI VERTICALI VERTICAL PROFILES	Alluminio anodizzato, con profili di regolazione interni in acciaio e plastica, staffe di scorrimento in acciaio con meccanismo di chiusura magnetico integrato. <i>Anodized aluminium, with internal profiles in steel and plastic, steel sliding brackets with integrated magnetic closing mechanism.</i>
MANIGLIA HANDLE	Metacrilato trasparente. <i>Methacrylate.</i>
TUBI APPENDIABILI CLOTHES RAILS	Tubo a sezione circolare in acciaio, verniciato a polveri epossidiche. <i>Steel rail with circular cross-section, painted with epoxy powder.</i>
CASSETTIERE DRAWER UNITS	Fianchi: pannello nobilitato spessore: 5 cm. Bordi: ABS in tinta. Coperchio: pannello nobilitato spessore: 3,8 cm oppure vetro temperato sp. 1 cm. Struttura del cassetto: pannello nobilitato spessore: 1,6 cm e 1,2 cm (fondo). Frontale cassetto: pannello nobilitato spessore: 1,9 cm. oppure vetro temperato sp. 0,8 cm con fissaggio alla struttura del cassetto mediante profilo ad L in alluminio anodizzato. Side panels: melamine panel 5 cm thick. Edges: ABS in a matching colour. Top: melamine panel 3,8 cm thick or tempered glass 1 cm thick. Drawer structure: melamine panel 1,6 cm thick and 1,2 cm thick (bottom). Drawer front: melamine panel 1,9 cm thick or tempered glass 0,8 cm thick attached to the drawer structure using an L-shaped anodised aluminium profile.
PORTA-PANTALONI E VASSOIO ESTRAIBILE TROUSER HOLDER AND PULL-OUT TRAY	Masselli laterali: pannello nobilitato spessore 5 cm. Telaio in legno di faggio sp. 4,6 cm con fondo poliestere e laccati con vernici all'acqua e pannello nobilitato spessore 2,5 cm. <i>Solid wood side elements: melamine panel 5 cm thick. Beechwood frame 4,6 cm thick with polyester bottom, lacquered with water-based paints and melamine panel 2,5 cm thick.</i>
SERVETTO PULL-DOWN HANGING ROD	Struttura in acciaio verniciato a polveri epossidiche e maniglia in plastica. <i>Steel structure painted with epoxy powder and plastic handle.</i>
PORTASCARPE SHOE RACK	Pannello nobilitato spessore 3,8 cm con inserti in acciaio sp. 0,3 cm, verniciati a polveri epossidiche. <i>Melamine panel 3,8 cm thick with steel inserts 0,3 cm thick, painted with epoxy powder.</i>

Struttura a vani
Compartment structure

- Struttura anche sospendibile
- Ampia modularità dei vani e anche soluzioni a misura
- Ampia gamma di attrezzatura interna e accessori (cassettiere, vassoi estraibili con porta pantaloni, ecc.)
- *Structure also suspendable*
- *Large modular of the compartments and also customized solutions*
- *Wide range of interior equipment and accessories (drawers and removable trays with trouser racks, etc.)*

A terra
On the floor

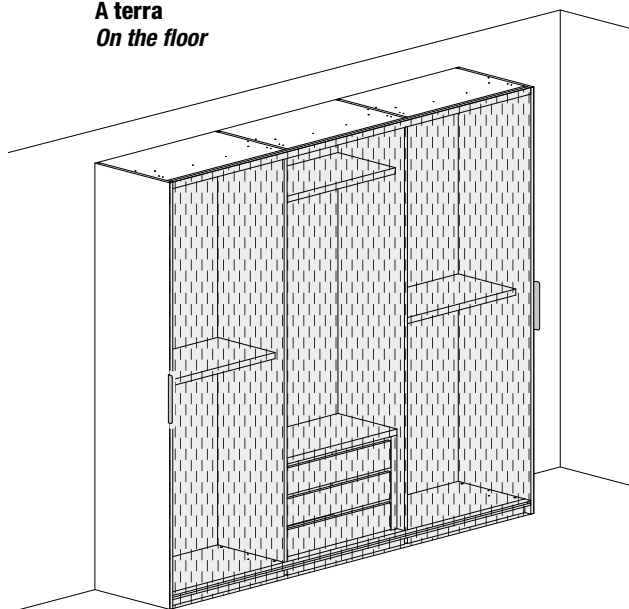

Sospesa
Suspended

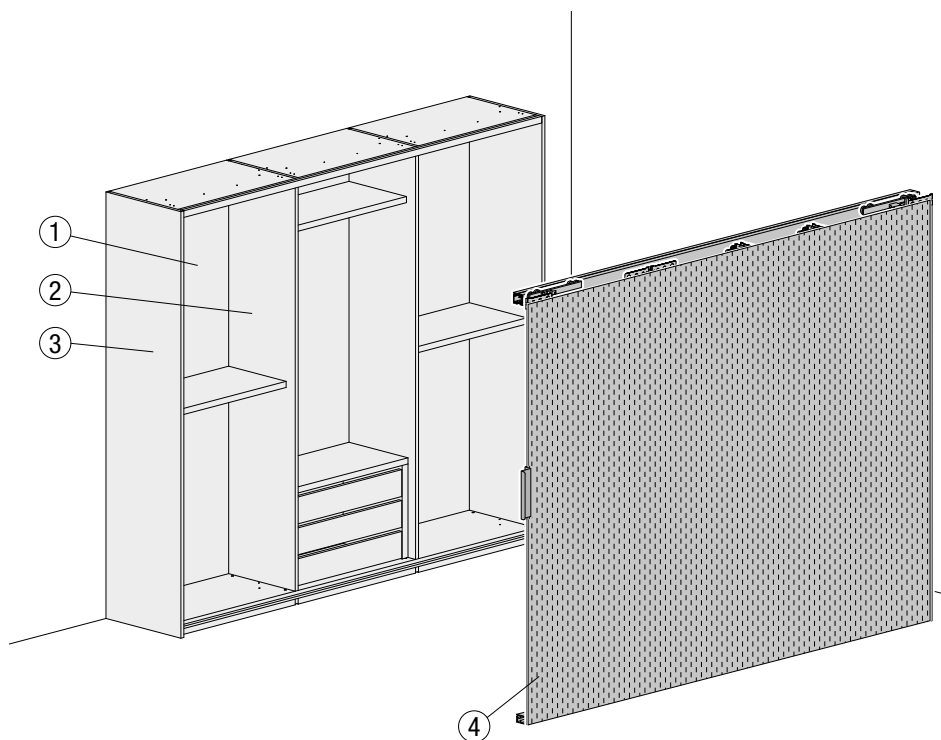
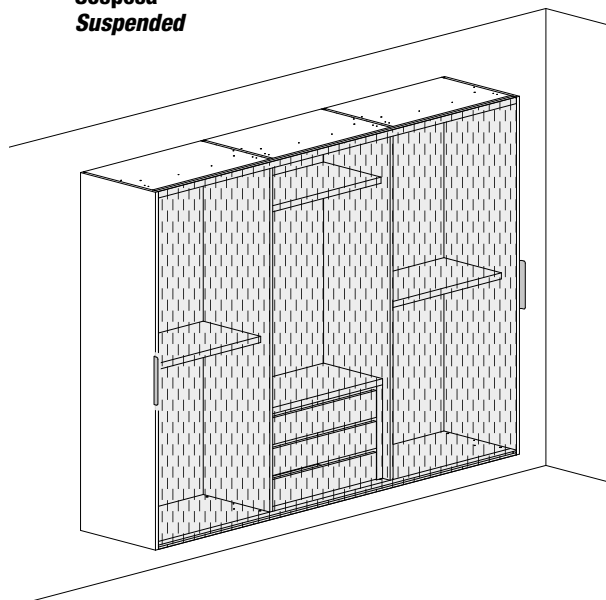

1. Vano
2. Fianco interno
3. Fianco esterno
4. Tessuto completo di binario superiore e inferiore e profili verticali con maniglia

1. *Compartment*
2. *Internal side*
3. *External side*
4. *Fabric complete with top and bottom track and vertical profiles with handle*

DETTAGLIO FORATURA SU FIANCHI PER ACCESSORI INTERNI
DETAIL OF DRILLING ON SIDES FOR INTERNAL ACCESSORIES

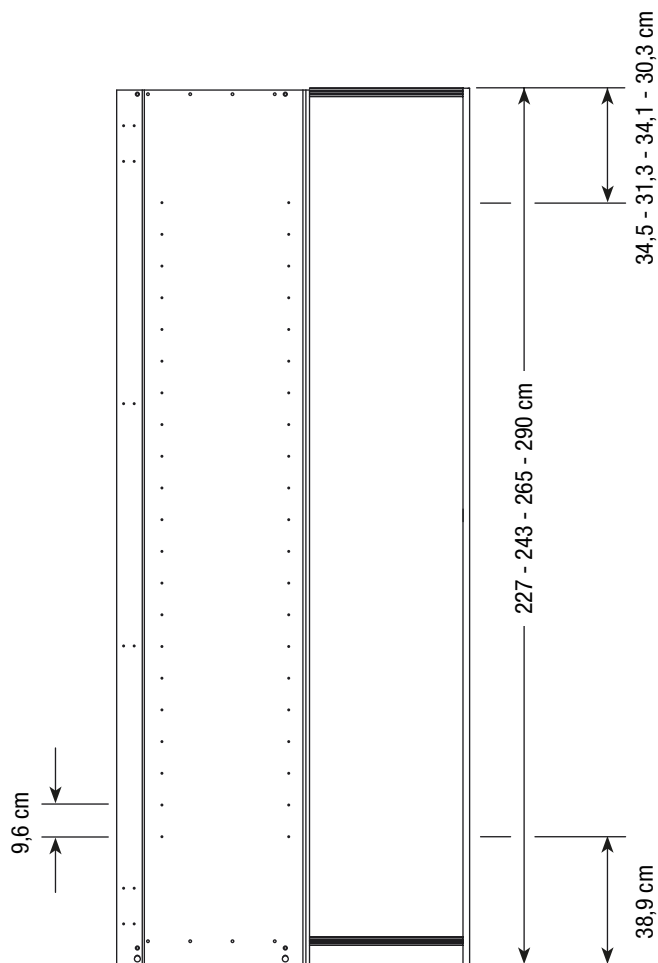

Su richiesta foratura per accessori interni solo dove previsti nell'ordine, senza sovrapprezzo.
Upon request, holes for internal accessories to be only where specified on the order, at no extra cost.

Ogni colonna deve prevedere almeno un ripiano in legno strutturale o una cassettera con coperchio in nobilitato per evitare la flessione dei fianchi.
Each tall unit must have at least one structural wooden shelf or a drawer unit with melamine top to prevent the side panels from bending.

I ripiani in vetro vanno posizionati tra due elementi strutturali in legno (es. tra il coperchio della colonna e il coperchio di una cassettera) e devono essere a una distanza massima tra loro di 125,3 cm.
Glass shelves must be positioned between two wooden structural elements (e.g. between a tall-unit top and a drawer-unit top) and must be a maximum of 125,3 cm apart.

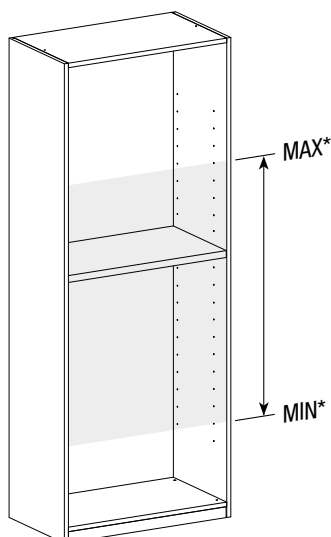

ALTEZZA DEL RIPIANO
SHELF HEIGHT

Altezza armadio Wardrobe height	Foro n° Hole no.	
	MIN*	MAX*
227	1	17
243	3	17
265	5	17
290	8	17

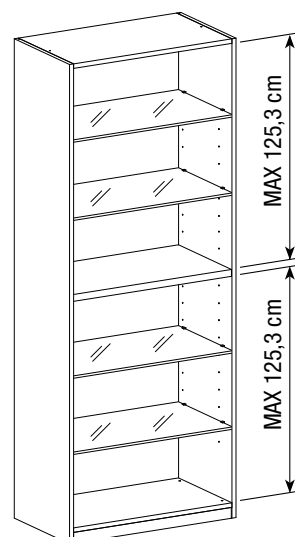
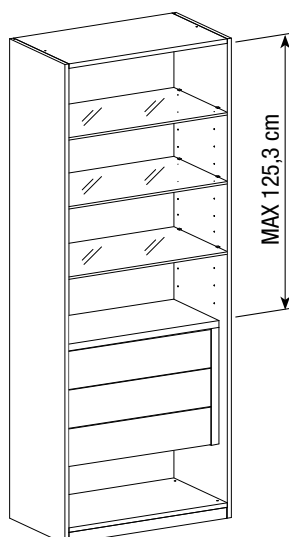

Misura al millimetro in larghezza e in altezza
Measure to the nearest millimeter in width and height

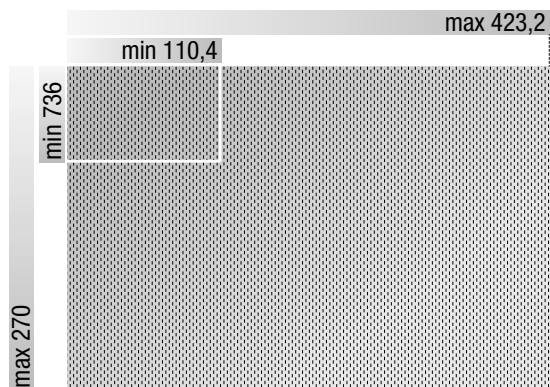

Struttura Albero
Tree Structure

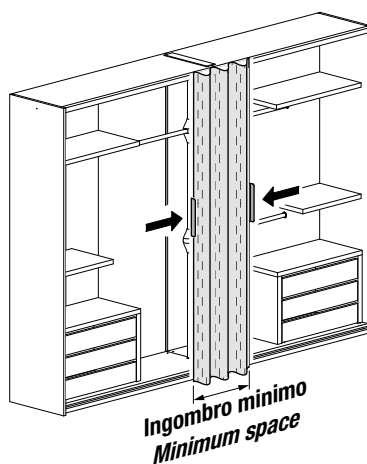

Struttura a vani
Compartment structure

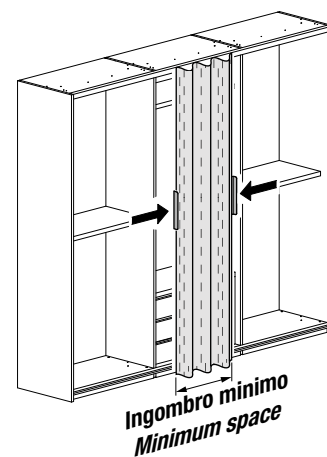

Quando il tessuto è tutto raccolto, questo ha un ingombro minimo che dipende dall'altezza e larghezza del mobile. Vedi tabella:
 When the fabric is all collected, it occupies minimum space that depends on the height and the width of the furniture. See chart below:

Ingombro minimo// Minimum space

ALTEZZA HEIGHT	LARGHEZZA WIDTH	110,4 ⇨ 140	140,1 ⇨ 171	171,1 ⇨ 203	203,1 ⇨ 235	235,1 ⇨ 277	277,1 ⇨ 314	314,1 ⇨ 350	350,1 ⇨ 381	381,1 ⇨ 423,2
73,6 ⇨ 184		51,5	57,4	63,3	69,2	75,1	81	86,9	92,8	98,7

ALTEZZA HEIGHT	LARGHEZZA WIDTH	128,8 ⇨ 140	140,1 ⇨ 171	171,1 ⇨ 203	203,1 ⇨ 235	235,1 ⇨ 277	277,1 ⇨ 314	314,1 ⇨ 350	350,1 ⇨ 381	381,1 ⇨ 423,2
184,1 ⇨ 270		58,6	58,6	63,3	69,2	75,1	81	86,9	92,8	98,7

Fianco laccato sp. 2,5 cm
Lacquered side thk 2.5 cm

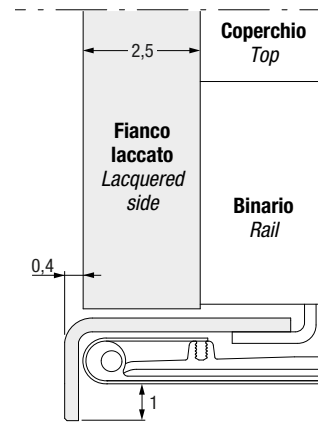
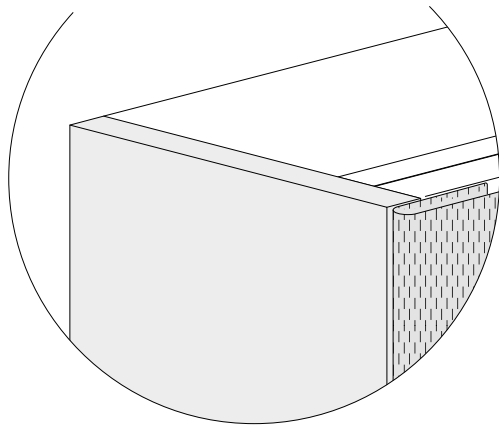

Fianco in tessuto sp. 3 cm
Fabric side thk 3 cm

Fianco in tessuto removibile e sfoderabile per lavaggio tessuto.
 Side with removable fabric for washing.

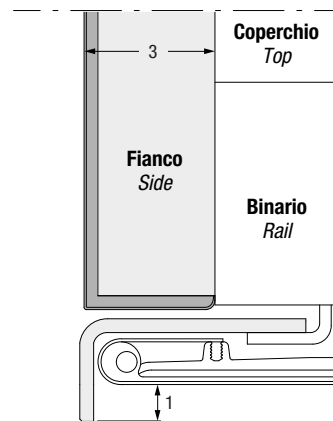
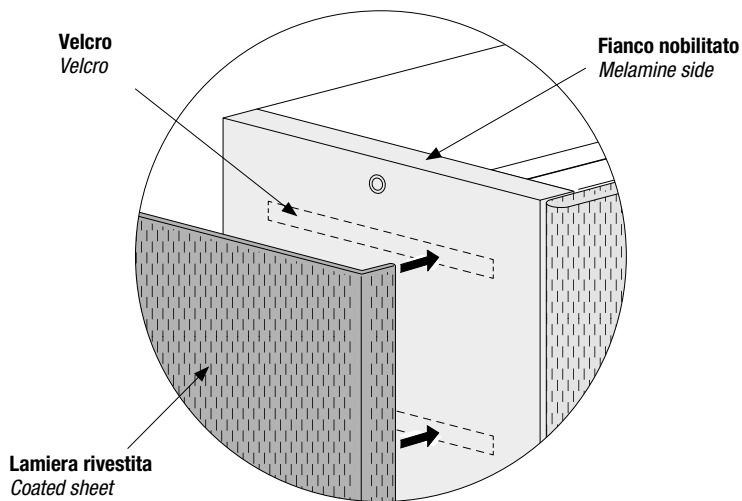

Fianco a parete sp. 5,5 cm
Filler side thk 5.5 cm

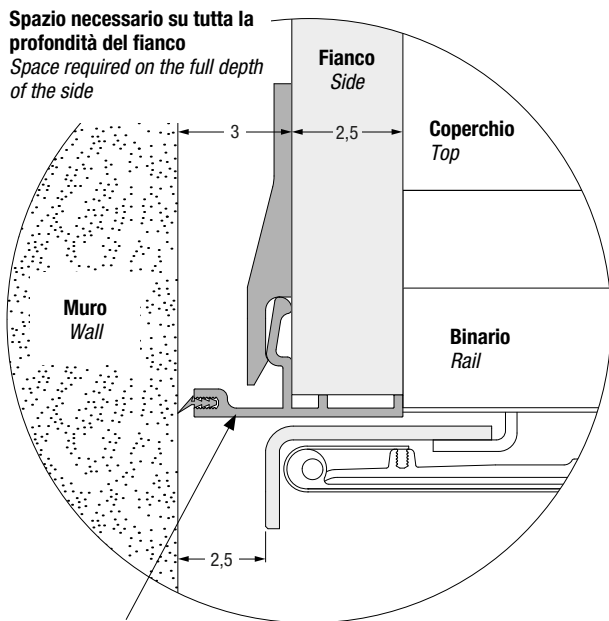
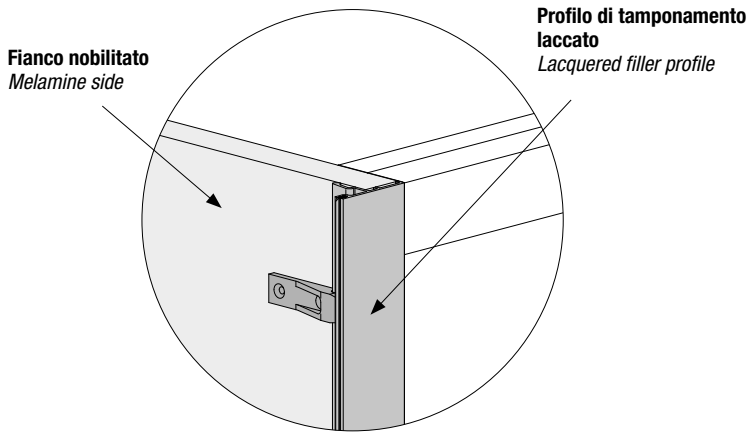

Profilo di tamponamento laccato
Lacquered filler profile

Fascia tamponamento fissa laccata
Fixed lacquered panelling

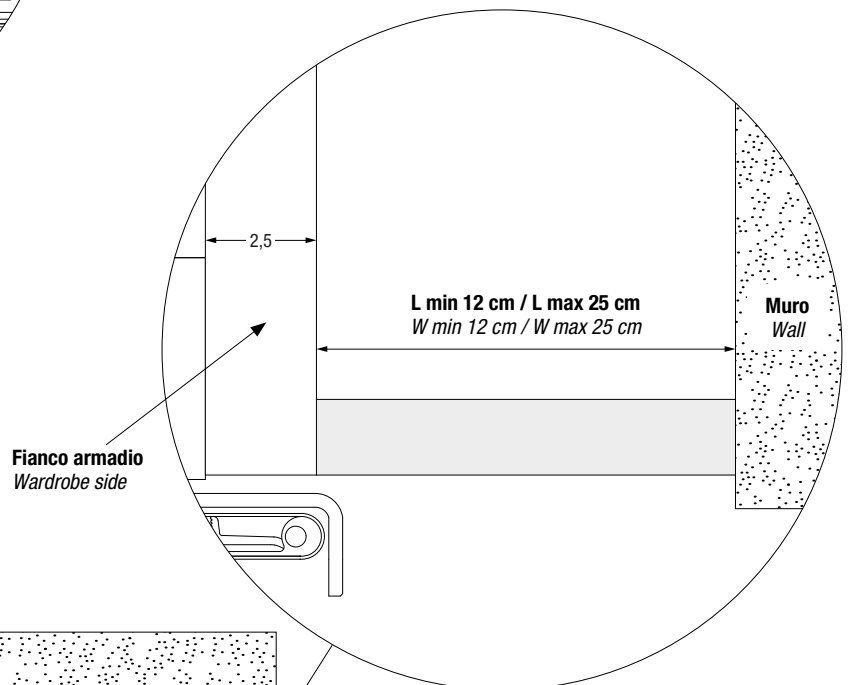

PIANTA
PLAN

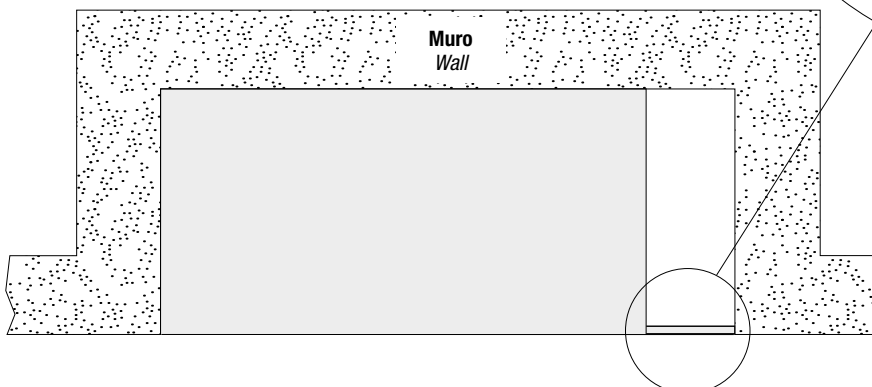

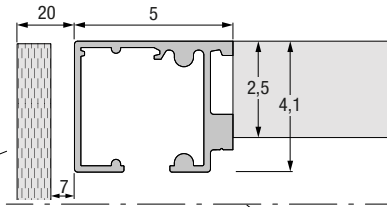

**Struttura Tree o
vani a terra
Tree structure or
compartment on
the ground**

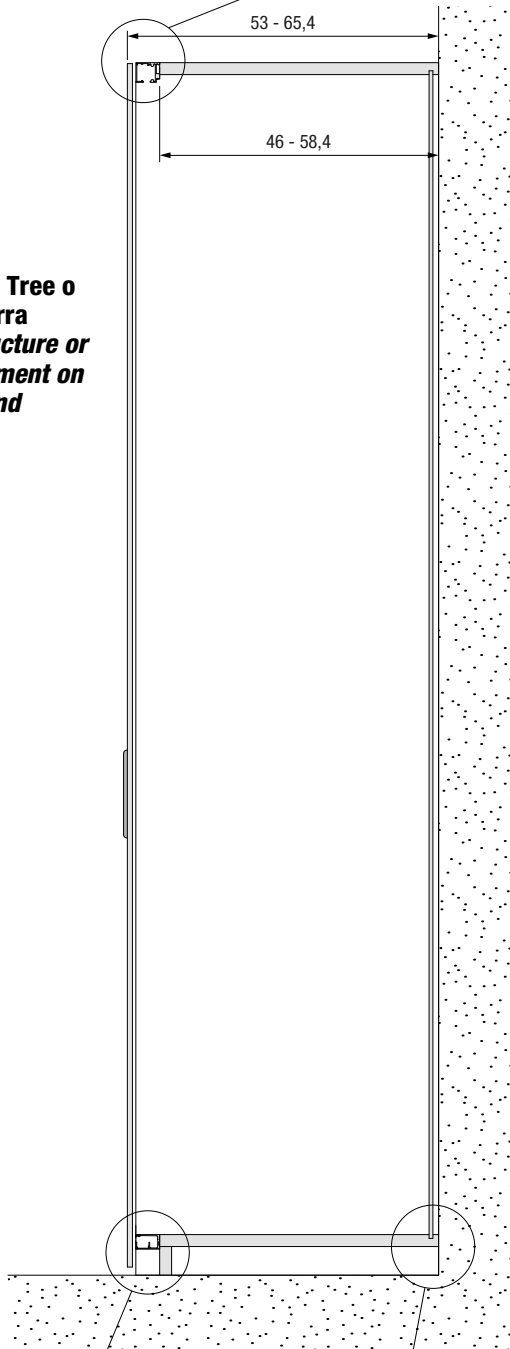

**Struttura a vani
sospesa
Hanging
compartment
structure**

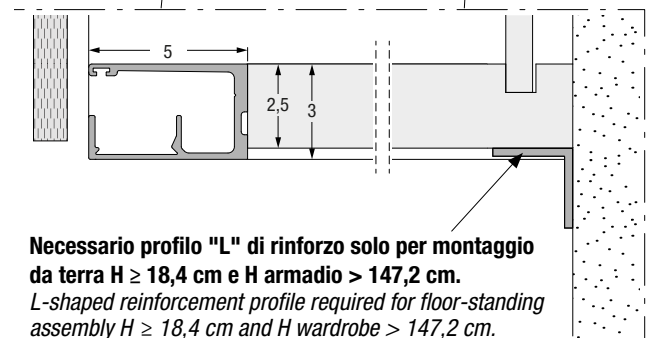
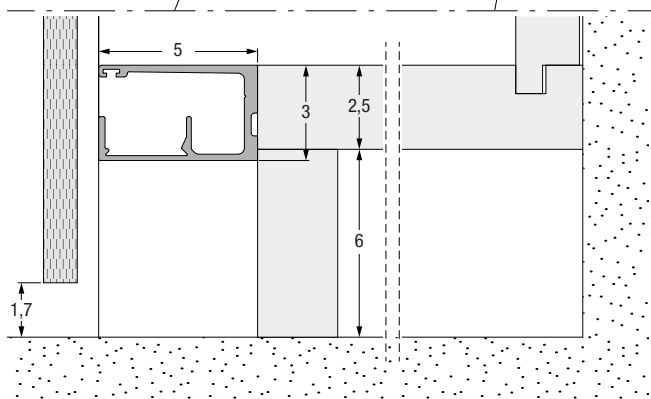
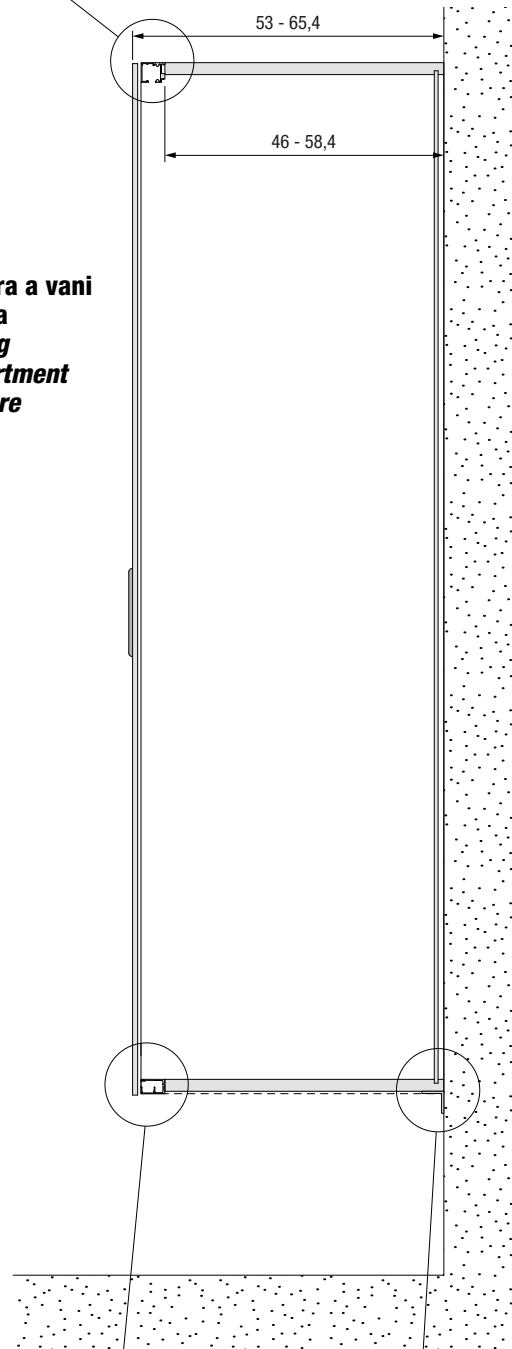

Necessario profilo "L" di rinforzo solo per montaggio da terra $H \geq 18,4$ cm e H armadio $> 147,2$ cm.
L-shaped reinforcement profile required for floor-standing assembly $H \geq 18,4$ cm and H wardrobe $> 147,2$ cm.

Raccomandazioni Recommendations

La sicurezza del montaggio dipende dal corretto fissaggio della piastra, questa è responsabilità dell'installatore che deve valutare le condizioni e le caratteristiche del muro e deve definire nei casi non previsti il tipo di fissaggio più idoneo (chimico o altro).

Per un supporto tecnico nella scelta del tipo di ancoraggio a muro è possibile contattare direttamente FISCHER tramite la mail dedicata per LAGO lago@fischeritalia.it o chiamando il numero **fischerpoint 800-844078** e richiedendo assistenza mobili LAGO.

The safety of the installation depends on the correct mounting of the plate, which is the responsibility of the installer, who has to assess the conditions and characteristics of the wall and define the most suitable type of installation (chemical or other).

*For technical support with the choice of the wall fitting method, please contact FISCHER directly through the dedicated e-mail to LAGO lago@fischeritalia.it or by giving them a call **fischerpoint 800-844078** and asking for assistance concerning LAGO furniture.*

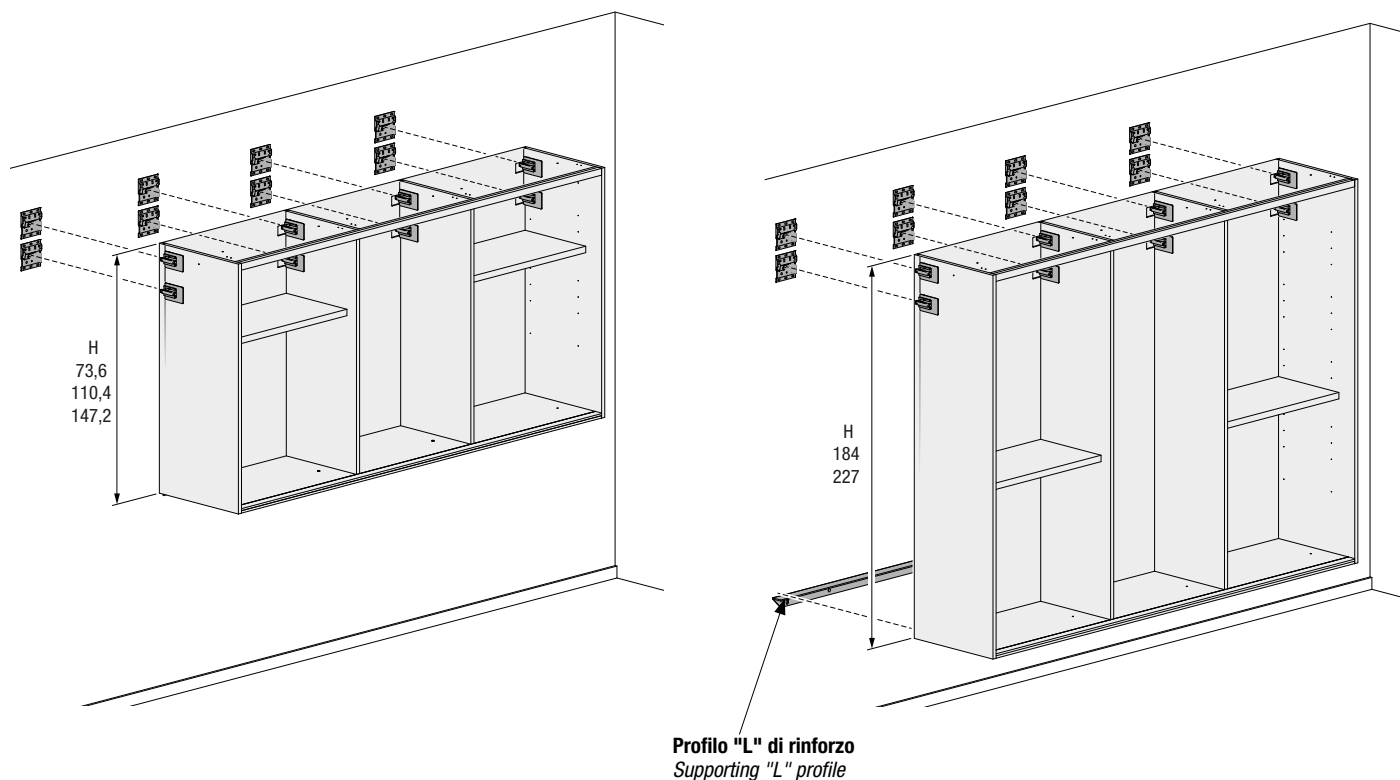

Rispettare i carichi massimi della colonna come da schema:
Observe the maximum loads as shown in the diagram:

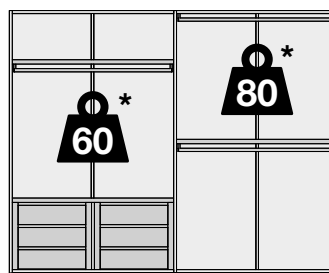

* Peso da aggiungere a quello della struttura
* Weight to be added to that of the structure

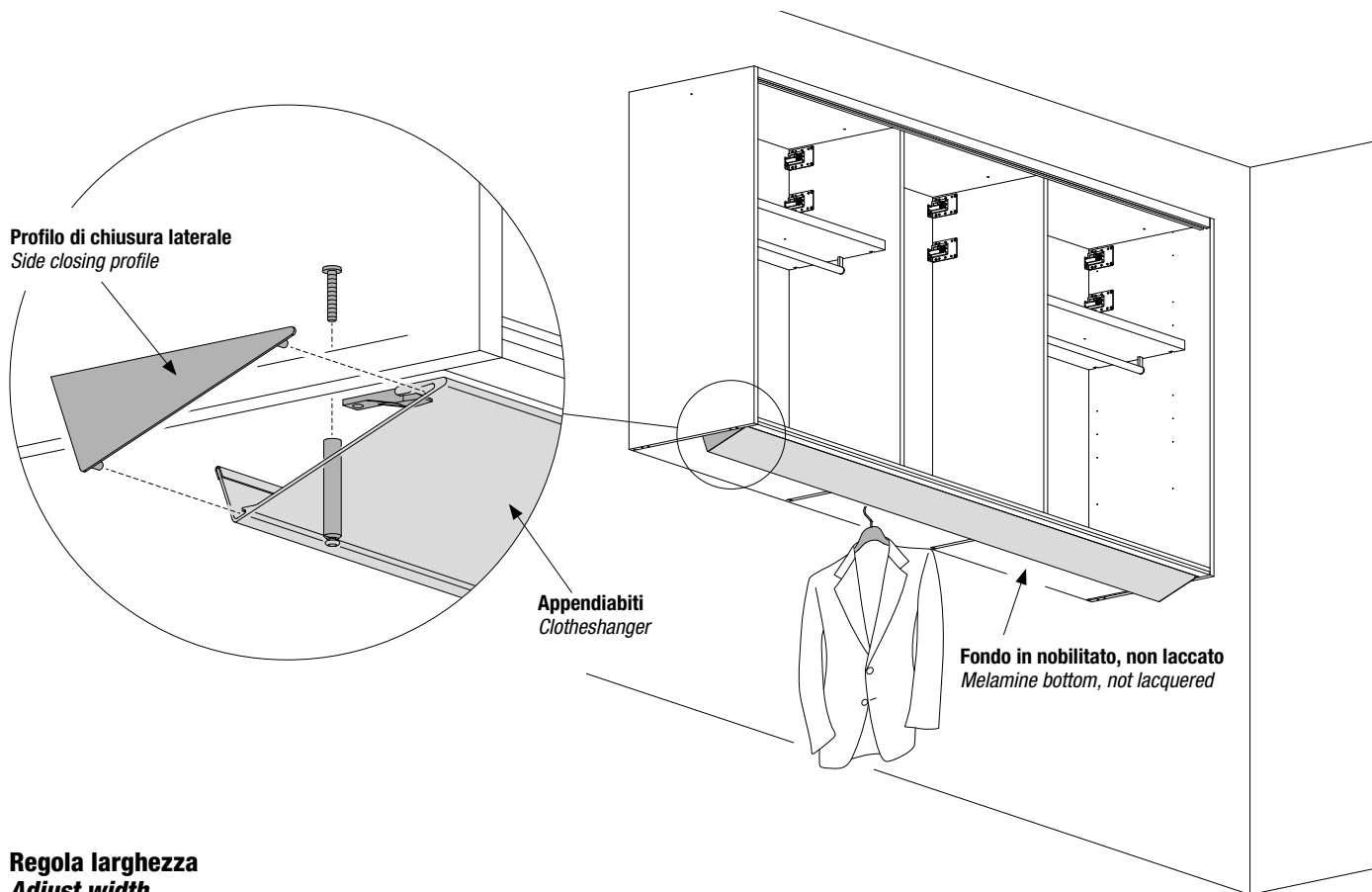

Regola larghezza
Adjust width

Il profilo viene fornito in un unico pezzo, la larghezza può coprire tutto l'armadio o una parte.
The profile is supplied in a single piece, the width may cover all or a part of the wardrobe.

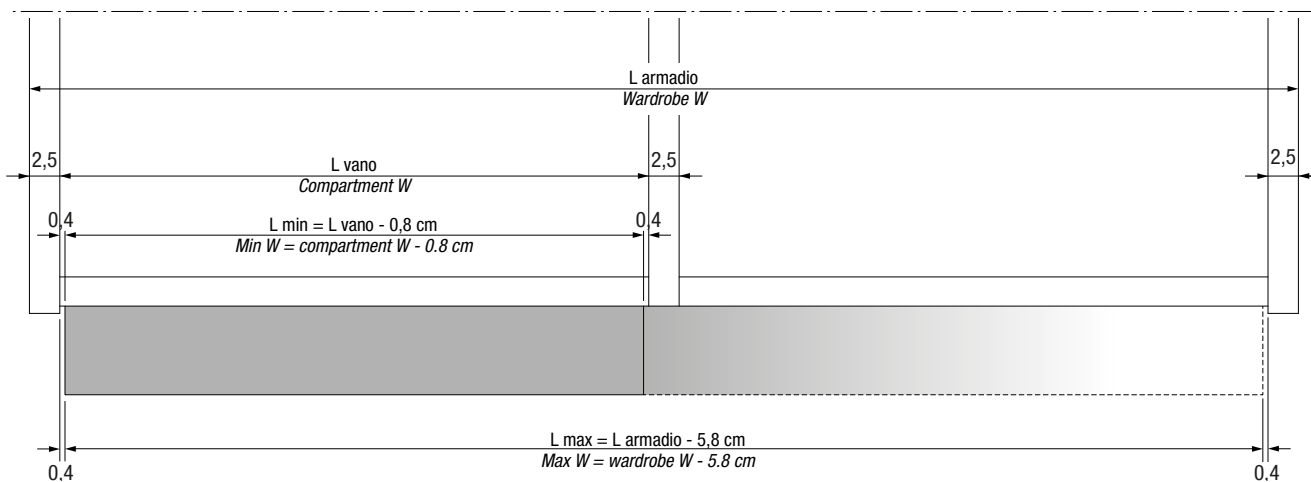

Regola profondità
Adjust depth

P armadio 65,4 cm
Wardrobe D 65.4 cm

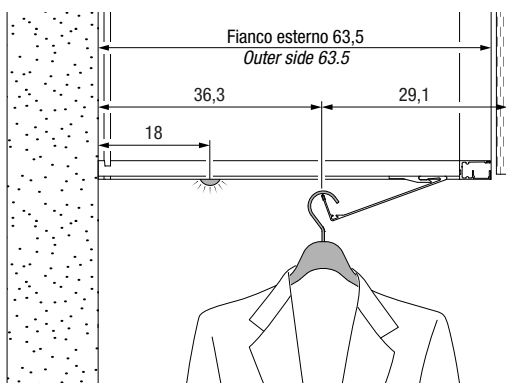

Striscia LED adesiva fornita in rotolo, luce calda 3200°K. Interruttore a parete. Si consiglia di usarla dietro al profilo appendiabiti o sotto armadi bassi (non a vista)
Adhesive LED strip supplied in rolls, 3200°K warm light. Switch on the wall. It is recommended to use it behind the clotheshanger profile or under low wardrobes (not visible)

P armadio 53 cm
Wardrobe D 53 cm

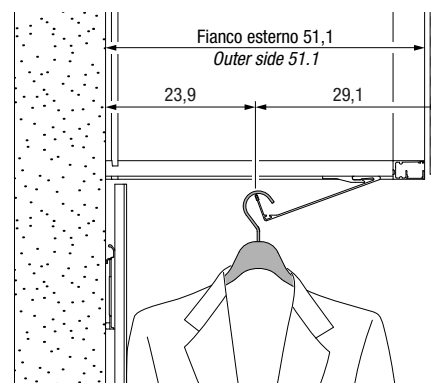

Ripiano estraibile
Pull-out shelf

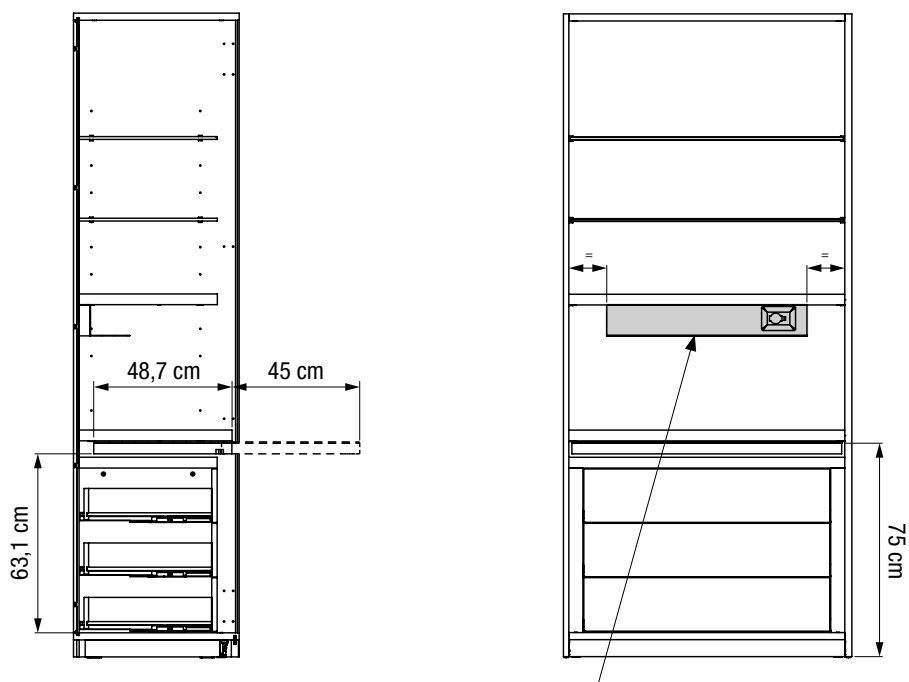

Ripiano accessorizzato da fissare al centro del ripiano.
Accessorised shelf to be fastened in the middle of the shelf.

TOP//TOP

Top vetro lucido laccato colori Lago sp. 0,4 cm
0.4 cm thk glossy lacquered glass top Lago colours

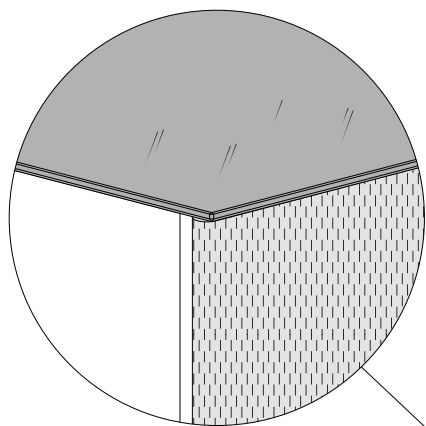

Top L max 270. Oltre fornito in 2 pezzi.
Max top W 270. In addition supplied in 2 pieces.

Illuminazione fondo armadio
Wardrobe bottom lighting

Striscia LED adesiva fornita in rotolo,
luce calda 3200°K. Interruttore a
parete.

Si consiglia di usarla dietro al profilo
appendiabiti o sotto armadi bassi
(non a vista)

*Adhesive LED strip supplied in rolls,
3200°K warm light. Switch on the
wall.*

*It is recommended to use it behind
the clotheshanger profile or under
low wardrobes (not visible)*

