Air

Note tecniche//*Technical Notes*

170

**Mensole
Shelves**



- sp. 8** H max 350 cm o massimo 10 mensole
- sp. 5** H max 245 cm o massimo 10 mensole
- sp. 8+5 (miste)** H max 250 cm o massimo 10 mensole
- Th. 8** max H 350 cm or up to 10 shelves
- Th. 5** max H 245 cm or up to 10 shelves
- Th. 8+5 (mixed)** max H 250 cm or up to 10 shelves

**Contenitori
Storage units**

**Composizioni centro stanza o non fissate a parete
Free-standing compositions**

Regole:

- H max composizione 210 cm
- Posizione contenitore H max 175 cm
- Larghezza max contenitore superiore 184 cm

Rules:

- Composition max height 210 cm
- 36e8 units must be placed at a max height of 175 cm
- Max width for upper 36e8 units 184 cm

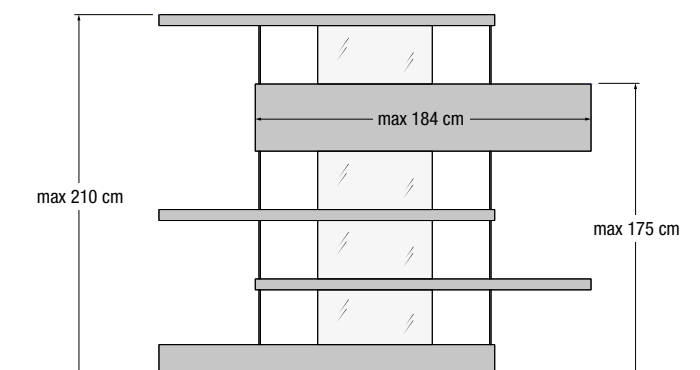

**Composizioni fissate a parete
Compositions against the wall**

Regole:

- H max composizione 245 cm
- Contenitore posizionato oltre H 175 cm da fissare a parete.

Rules:

- Composition max height 245 cm
- Storage units placed above H 175 cm must be wall mounted.

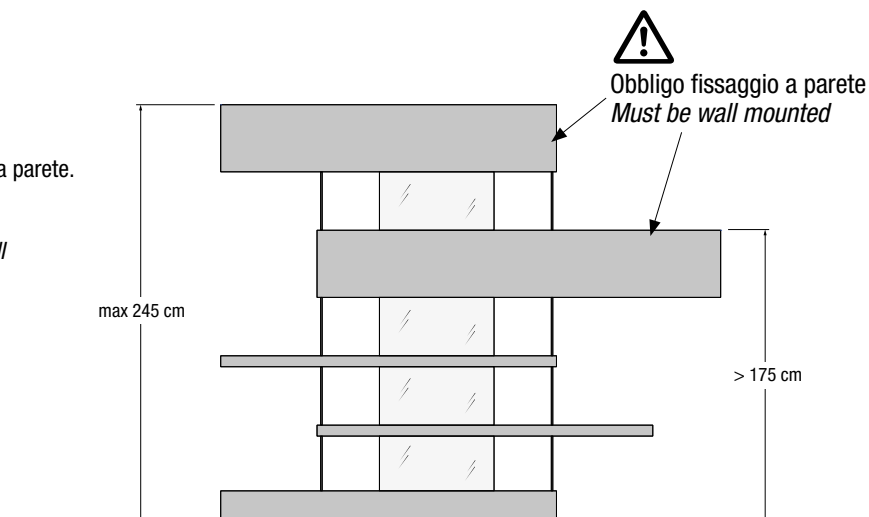

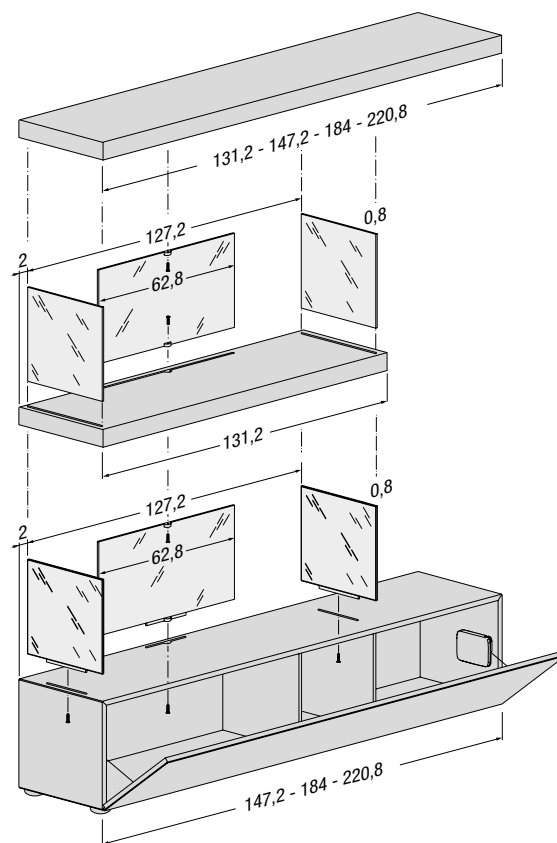

AIR SET VETRI//AIR GLASS SET

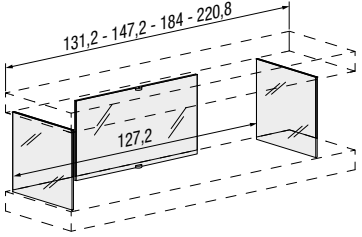
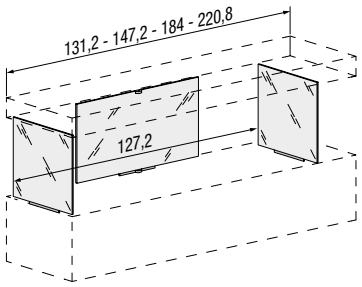
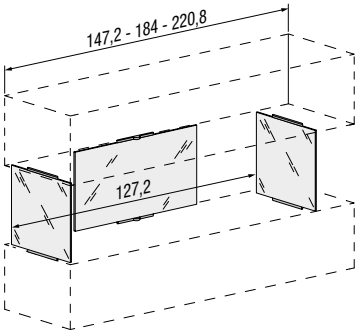
Descrizione//Description	Profondità Depth	Altezza vetri Glass height	Codice Code	Vetro extra-chiaro Extra-clear glass	Vetro fumè* Smoked glass*
Set vetri mensola - mensola <i>Glass set between 2 shelves</i> 	40,6	13,8	AIR8001		
		18,4	AIR8011		
		23	AIR8021		
		25	AIR8191		
		27,6	AIR8031		
		32,2	AIR8041		
		32,8	AIR8051		
		34,3	AIR8061		
		36,8	AIR8071		
		37,4	AIR8081		
		38,9	AIR8091		
73,6	AIR8101				
82,8	AIR8111				
Set vetri mensola - contenitore <i>Glass set between a shelf and a storage unit</i> 	40,6	13,8	AIR8003		
		18,4	AIR8012		
		23	AIR8022		
		25	AIR8192		
		27,6	AIR8032		
		32,2	AIR8042		
		32,8	AIR8052		
		34,3	AIR8062		
		36,8	AIR8072		
		37,4	AIR8082		
		38,9	AIR8092		
73,6	AIR8102				
82,8	AIR8112				
Set vetri contenitore - contenitore <i>Glass set between storage units</i> 	40,6	13,8	AIR8000		
		18,4	AIR8010		
		23	AIR8020		
		25	AIR8190		
		27,6	AIR8030		
		32,2	AIR8040		
		32,8	AIR8050		
		34,3	AIR8060		
		36,8	AIR8070		
		37,4	AIR8080		
		38,9	AIR8090		
	73,6	AIR8100			
	82,8	AIR8110			
	51	18,4	AIR8120		
		25	AIR8300		
32,2		AIR8310			
36,8		AIR8180			

AIR SET VETRI//AIR GLASS SET

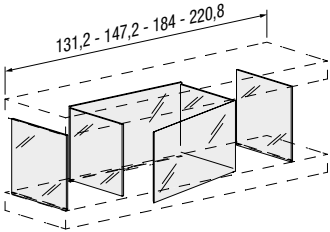
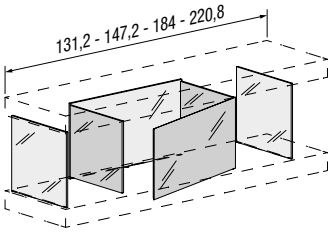
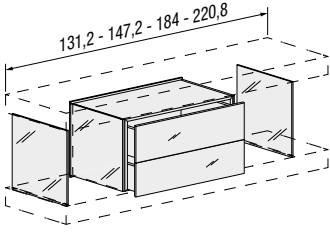
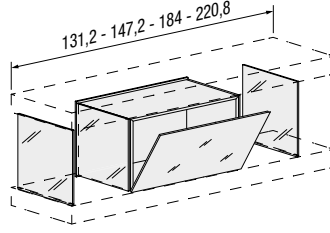
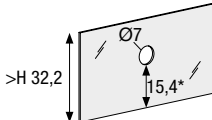
Descrizione/Description	Profondità mensola Shelf depth	Altezza vetri Glass height	Codice Code	Vetro extra-chiaro Extra-clear glass	Vetro fumè* Smoked glass*	
Set vetri contenitore per libreria - Solo tra mensola-mensola <i>Bookshelf storage unit glass set- Only between shelf-shelf</i> 	40,6	32,2	AIR707			
Set vetri contenitore laccato con schienale vetro extra-chiaro - Solo tra mensola-mensola <i>Glass set for lacquered storage unit with extra-clear glass back - Shelf-shelf only</i> 	40,6	32,2	AIR707		Vetro Glass	
Set vetri contenitore 2 cassetti rivestito in vetro laccato <i>Sempre finito con fianchi e schiena in vetro</i> Glass set for storage unit with 2 drawers and lacquered glass cladding <i>Finishes with side panels and glass back</i> 	40,6	32,2	AIR740	Vetro lucido Polished glass	Vetro opaco Matt glass	XGlass lucido o opaco Polished or matt XGlass
Set vetri contenitore ribalta rivestito in vetro laccato <i>Sempre finito con fianchi e schiena in vetro</i> Glass set for storage unit with flap door and lacquered glass cladding <i>Finishes with side panels and glass back</i> 	40,6	32,2	AIR750	Vetro lucido Polished glass	Vetro opaco Matt glass	XGlass lucido o opaco Polished or matt XGlass
Lavorazione su schienale vetro per foro passacavi <i>Machining on glass back for cable hole</i> 			RID034	Maggiorazione Extra Cost		
* Posizione fissa <i>* Fixed position</i>						

*Il vetro fumè è disponibile nelle finiture grigio e bronzo.
 *The smoked glass is available in the Grey and Bronze finishes.

AIR MENSOLE SP. 5 CM//AIR SHELVES 5 CM THICK

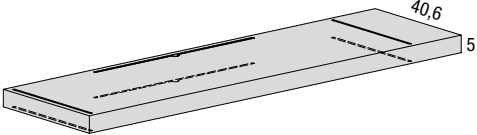
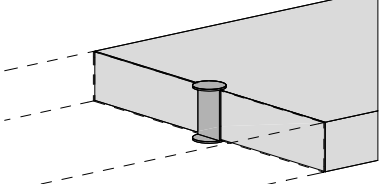
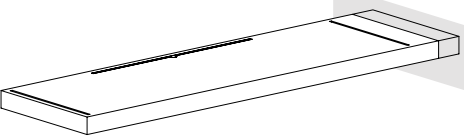
Descrizione//Description	Larghezza Width	Profondità Depth	Codice Code	Laccato Lacquered
Coperchio, fondo o mensola reversibile <i>Top, bottom or reversible shelf</i> 	131,2	40,6	AIR320	
	147,2	40,6	AIR321	
	184	40,6	AIR322	
Elemento di giunzione per mensola opzionale <i>Optional shelf connecting element</i> 	Codice Code			Acciaio spazzolato <i>Brushed steel</i>
	AIR601			
Riduzione larghezza solo per coperchio, fondo o mensola reversibile sp. 5 cm * <i>Width reduction for top, bottom or reversible shelf 5 cm thick only *</i>  * Larghezza minima 131,2 cm * Minimum width 131.2 cm	Codice Code			Maggiorazione <i>Extra Cost</i>
	RID033			

AIR MENSOLE SP. 8 CM//AIR SHELVES 8 CM THICK

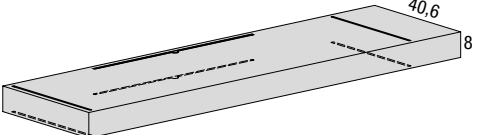
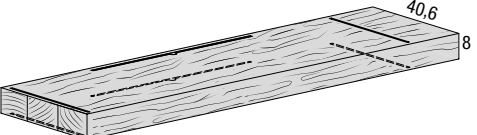
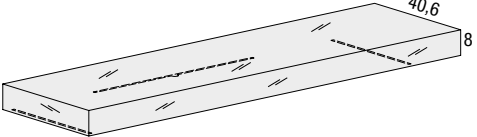
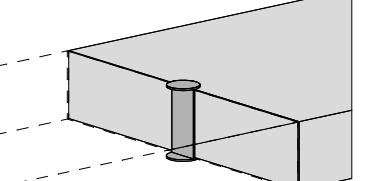
Descrizione//Description	Larghezza Width	Profondità Depth	Codice Code	Laccato Lacquered		
Coperchio, fondo o mensola reversibile <i>Top, bottom or reversible shelf</i> 	131,2	40,6	AIR213			
	147,2		AIR214			
	184		AIR218			
	220,8		AIR222			
Coperchio, fondo o mensola reversibile <i>Top, bottom or reversible shelf</i> 	Larghezza Width	Profondità Depth	Codice Code	Wildwood		
	131,2	40,6	AIW023			
	147,2		AIW024			
	184		AIW025			
	220,8		AIW026			
Coperchio <i>Top</i> 	Larghezza Width	Profondità Depth	Codice Code	Vetro Lucido Polished Glass	Vetro opaco Matt glass	XGlass lucido o opaco polished or matt
	147,2	40,6	AIV214			
	184		AIV218			
	220,8		AIV222			
Elemento di giunzione per mensola opzionale <i>Optional shelf connecting element</i> 	Codice Code			Acciaio spazzolato <i>Brushed steel</i>		
	AIR600					

AIR FONDI A TERRA//AIR FLOOR-STANDING BOTTOMS

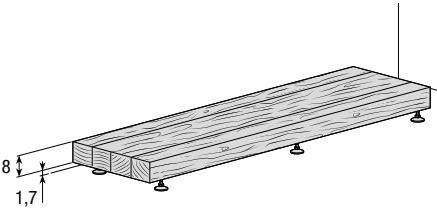
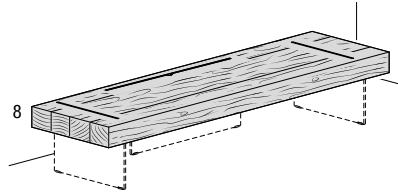
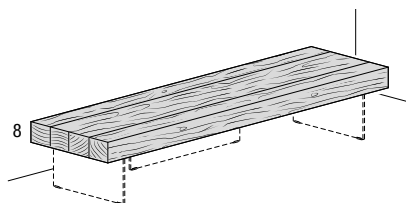
Descrizione/Description	Larghezza Width	Profondità Depth	Codice Code	Wildwood
Fondo a terra con piedini <i>Floor-standing base with feet</i> 	73,6	40,6	AIW001F	
	92		AIW002F	
	110,4		AIW003F	
	131,2		AIW009F	
	147,2		AIW004F	
	184		AIW005F	
	220,8		AIW006F	
	257,6		AIW007F	
	294,4		AIW008F	
	73,6	51	AIW101F	
	92		AIW102F	
	110,4		AIW103F	
	131,2		AIW109F	
	147,2		AIW104F	
	184		AIW105F	
	220,8		AIW106F	
	257,6		AIW107F	
	294,4		AIW108F	
Fondo per set vetri a terra Con fresate per vetri libreria <i>Base for floor-standing glass set</i> <i>With grooves for bookcase glass panels</i>  Specificare verso dx/sx <i>Please specify right or left orientation</i>	147,2	40,6	AIW204	
	184		AIW205	
	220,8		AIW206	
	257,6		AIW207	
	294,4		AIW208	
	147,2		51	AIW304
	184	AIW305		
	220,8	AIW306		
	257,6	AIW307		
	294,4	AIW308		
	Fondo per set vetri a terra <i>Base for floor-standing glass set</i> 	147,2	40,6	AIW204F
184		AIW205F		
220,8		AIW206F		
257,6		AIW207F		
294,4		AIW208F		
147,2		51		AIW304F
184			AIW305F	
220,8			AIW306F	
257,6			AIW307F	
294,4			AIW308F	

P. 40,6 AIR CONTENITORI//D. 40,6 AIR STORAGE UNITS

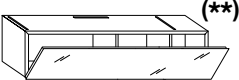
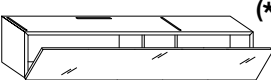
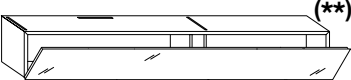
Altezza Height	Larghezza Width	147,2	184	220,8
Struttura laccata o Rovere Gentile//Lacquered or Gentle oak structure				
18,4 Vasistas//Top hung opening				
Frontale//Front				
Laccato//Lacquered				
Vetro lucido o specchio//Polished glass or mirror				
Vetro opaco//Matt glass	AI100V	AI101V		
XGlass lucido o opaco//Polished or matt XGlass				
Wildwood				
18,4 Ribalta//Bottom hung opening				
Frontale//Front				
Laccato//Lacquered				
Vetro lucido o specchio//Polished glass or mirror				
Vetro opaco//Matt glass	AI100R	AI101R		
XGlass lucido o opaco//Polished or matt XGlass				
Wildwood				
18,4 1 cassetto//1 drawer				
Frontale//Front				
Laccato//Lacquered				
Vetro lucido o specchio//Polished glass or mirror				
Vetro opaco//Matt glass	AI120	AI121		
XGlass lucido o opaco//Polished or matt XGlass				
Wildwood				
27,6 Ribalta//Bottom hung opening				
Frontale//Front				
Laccato//Lacquered				
Vetro lucido o specchio//Polished glass or mirror				
Vetro opaco//Matt glass	AI140R	AI141R	AI142R	
XGlass lucido o opaco//Polished or matt XGlass				
Wildwood				
27,6 Cestone//Deep drawer				
Frontale//Front				
Laccato//Lacquered				
Vetro lucido o specchio//Polished glass or mirror				
Vetro opaco//Matt glass	AI160	AI161		
XGlass lucido o opaco//Polished or matt XGlass				
Wildwood				
36,8 Vasistas//Top hung opening				
Frontale//Front				
Laccato//Lacquered				
Vetro lucido o specchio//Polished glass or mirror				
Vetro opaco//Matt glass	AI110V	AI111V	AI112V	
XGlass lucido o opaco//Polished or matt XGlass				
Wildwood				
36,8 Ribalta//Bottom hung opening				
Frontale//Front				
Laccato//Lacquered				
Vetro lucido o specchio//Polished glass or mirror				
Vetro opaco//Matt glass	AI110R	AI111R	AI112R	
XGlass lucido o opaco//Polished or matt XGlass				
Wildwood				
36,8 Cestone//Deep drawer				
Frontale//Front				
Laccato//Lacquered				
Vetro lucido o specchio//Polished glass or mirror				
Vetro opaco//Matt glass	AI140	AI141		
XGlass lucido o opaco//Polished or matt XGlass				
Wildwood				

(**) Nel caso in cui il contenitore 36e8 venga utilizzato come scrittoio è necessario prevedere il fissaggio a parete.

(**) If the 36e8 storage unit is used as a desk, it must be wall mounted.

P. 40,6 AIR CONTENITORI//D. 40,6 AIR STORAGE UNITS

Altezza Height	Larghezza Width	147,2	184	220,8
Struttura laccata o Rovere Gentile//Lacquered or Gentle oak structure				
36,8 2 cassetti//2 drawers				
Frontale//Front		(***)	(***)	
Laccato//Lacquered				
Vetro lucido o specchio//Polished glass or mirror				
Vetro opaco//Matt glass	AI130		AI131	
XGlass lucido o opaco//Polished or matt XGlass				
Wildwood				
55,2 2 cestoni//2 deep drawers				
Frontale//Front				
Laccato//Lacquered				
Vetro lucido o specchio//Polished glass or mirror				
Vetro opaco//Matt glass	AI170		AI171	
XGlass lucido o opaco//Polished or matt XGlass				
Wildwood				
55,2 Anta battente//Hinged door				
Frontale//Front				
Laccato//Lacquered				
Vetro lucido o specchio//Polished glass or mirror				
Vetro opaco//Matt glass	AI120B		AI121B	AI122B
XGlass lucido o opaco//Polished or matt XGlass				
Wildwood				
73,6 Anta battente//Hinged door				
Frontale//Front				
Laccato//Lacquered				
Vetro lucido o specchio//Polished glass or mirror				
Vetro opaco//Matt glass	AI130B		AI131B	AI132B
XGlass lucido o opaco//Polished or matt XGlass				
Wildwood				

(***) Cassettiere con frontali unici di larghezza maggiore di 110,4 non sono utilizzabili a terra se il frontale non è accessibile dall'alto poiché l'apertura laterale non è efficace.
 (***) Chests of drawers with single fronts wider than 110,4 cannot be used as floor-standing units if the front is not accessible from above, as the side opening is not functional.

P. 51 AIR CONTENITORI//D. 51 AIR STORAGE UNITS

Altezza Height	Larghezza Width	147,2	184	220,8
Struttura laccata o Rovere Gentile//Lacquered or Gentle oak structure				
18,4 Vasistas//Top hung opening				
Frontale//Front				
Laccato//Lacquered				
Vetro lucido o specchio//Polished glass or mirror				
Vetro opaco//Matt glass		AI300V		
XGlass lucido o opaco//Polished or matt XGlass				
Wildwood				
18,4 Ribalta//Bottom hung opening				
Frontale//Front				
Laccato//Lacquered				
Vetro lucido o specchio//Polished glass or mirror				
Vetro opaco//Matt glass		AI300R	AI301R	
XGlass lucido o opaco//Polished or matt XGlass				
Wildwood				
18,4 1 cassetto//1 drawer				
Frontale//Front				
Laccato//Lacquered				
Vetro lucido o specchio//Polished glass or mirror				
Vetro opaco//Matt glass		AI320	AI321	
XGlass lucido o opaco//Polished or matt XGlass				
Wildwood				
27,6 Ribalta//Bottom hung opening				
Frontale//Front				
Laccato//Lacquered				
Vetro lucido o specchio//Polished glass or mirror				
Vetro opaco//Matt glass		AI340R	AI341R	AI342R
XGlass lucido o opaco//Polished or matt XGlass				
Wildwood				
27,6 Cestone//Deep drawer				
Frontale//Front				
Laccato//Lacquered				
Vetro lucido o specchio//Polished glass or mirror				
Vetro opaco//Matt glass		AI360	AI361	
XGlass lucido o opaco//Polished or matt XGlass				
Wildwood				
36,8 Vasistas//Top hung opening				
Frontale//Front				
Laccato//Lacquered				
Vetro lucido o specchio//Polished glass or mirror				
Vetro opaco//Matt glass		AI310V		
XGlass lucido o opaco//Polished or matt XGlass				
Wildwood				
36,8 Ribalta//Bottom hung opening				
Frontale//Front				
Laccato//Lacquered				
Vetro lucido o specchio//Polished glass or mirror				
Vetro opaco//Matt glass		AI310R	AI311R	
XGlass lucido o opaco//Polished or matt XGlass				
Wildwood				
36,8 Cestone//Deep drawer				
Frontale//Front				
Laccato//Lacquered				
Vetro lucido o specchio//Polished glass or mirror				
Vetro opaco//Matt glass		AI340	AI341	
XGlass lucido o opaco//Polished or matt XGlass				
Wildwood				

P. 51 AIR CONTENITORI//D. 51 AIR STORAGE UNITS

Altezza Height	Larghezza Width	147,2	184	220,8
Struttura laccata o Rovere Gentile//Lacquered or Gentle oak structure				
36,8 2 cassetti//2 drawers				
Frontale//Front		(***)	(***)	
Laccato//Lacquered				
Vetro lucido o specchio//Polished glass or mirror				
Vetro opaco//Matt glass	AI230		AI231	
XGlass lucido o opaco//Polished or matt XGlass				
Wildwood				
55,2 2 cestoni//2 deep drawers				
Frontale//Front				
Laccato//Lacquered				
Vetro lucido o specchio//Polished glass or mirror				
Vetro opaco//Matt glass	AI370		AI371	
XGlass lucido o opaco//Polished or matt XGlass				
Wildwood				
55,2 Anta battente//Hinged door				
Frontale//Front				
Laccato//Lacquered				
Vetro lucido o specchio//Polished glass or mirror				
Vetro opaco//Matt glass	AI320B		AI321B	AI322B
XGlass lucido o opaco//Polished or matt XGlass				
Wildwood				
73,6 Anta battente//Hinged door				
Frontale//Front				
Laccato//Lacquered				
Vetro lucido o specchio//Polished glass or mirror				
Vetro opaco//Matt glass	AI330B		AI331B	AI332B
XGlass lucido o opaco//Polished or matt XGlass				
Wildwood				

(***) Cassettiere con frontali unici di larghezza maggiore di 110,4 non sono utilizzabili a terra se il frontale non è accessibile dall'alto poiché l'apertura laterale non è efficace.
 (***) Chests of drawers with single fronts wider than 110,4 cannot be used as floor-standing units if the front is not accessible from above, as the side opening is not functional.

AIR SET VETRI A TERRA//AIR FLOOR-STANDING GLASS SET

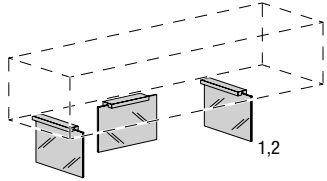
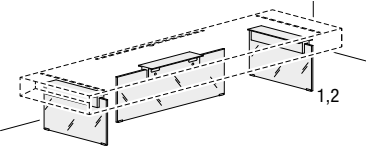
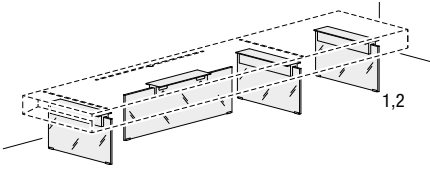
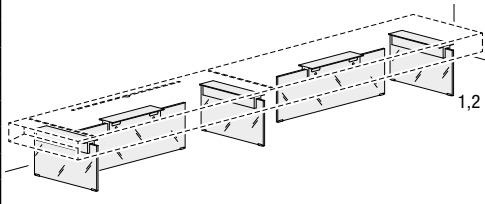
Descrizione//Description	Profondità contenitore Storage unit depth	Altezza vetri Glass height	Codice Code	Vetro extra-chiaro Extra-clear glass	Vetro fumè grigio Fumè Grigio glass	
Set vetri a terra per contenitori L. 147,2 - 184 - 220,8 <i>Floor glass set for units only W. 147.2 - 184.0 - 220.8</i> 	40,6	9,2	AIR9011			
		18,4	AIR9021			
		27,6	AIR9031			
		36,8	AIR9041			
	51	9,2	AIR9111			
		18,4	AIR9121			
		27,6	AIR9131			
		36,8	AIR9141			
	Set vetri a terra per fondo in Wildwood L. 147,2 - 184 - 220,8 <i>Floor glass set for Wildwood base W. 147.2 - 184.0 - 220.8</i> 	40,6	9,2	AIW901		
			18,4	AIW902		
27,6			AIW903			
36,8			AIW904			
51		9,2	AIW911			
		18,4	AIW912			
		27,6	AIW913			
		36,8	AIW914			
Set vetri a terra per fondo in Wildwood L. 257,6 <i>Floor glass set for Wildwood base W. 257.6</i> 		40,6	9,2	AIW921		
			18,4	AIW922		
			27,6	AIW923		
			36,8	AIW924		
		51	9,2	AIW931		
			18,4	AIW932		
	27,6		AIW933			
	36,8		AIW934			
	Set vetri a terra per fondo in Wildwood L. 294,4 <i>Floor glass set for Wildwood base W. 294.4</i> 	40,6	9,2	AIW941		
			18,4	AIW942		
			27,6	AIW943		
			36,8	AIW944		
		51	9,2	AIW951		
			18,4	AIW952		
27,6			AIW953			
36,8			AIW954			

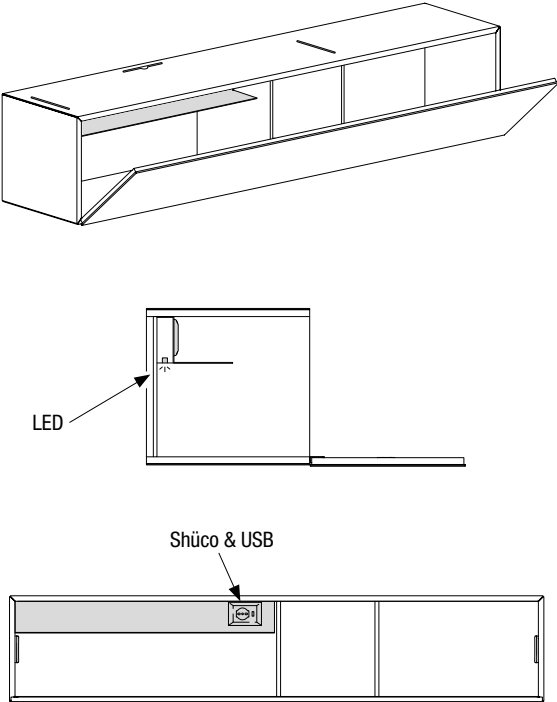
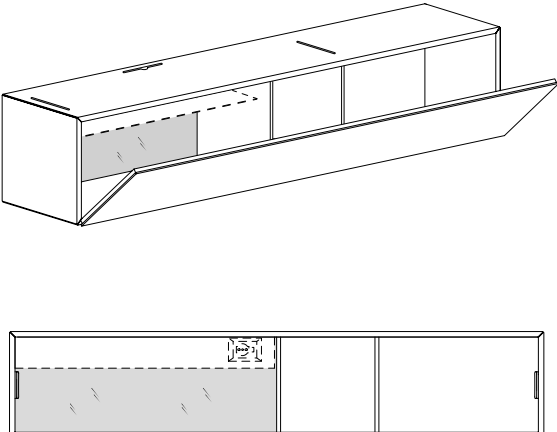
Descrizione//Description	Altezza Height	Larghezza Width	Profondità Depth	Codice Code	Metallo** Metal**	
<p>Ripiano accessorizzato per scrittoio 36e8 Il ripiano include: - illuminazione interna (LED da incasso, accensione touch system, luce dimerabile 3000°K), - alimentatore (12V, 6 uscite max 30W), - plug presa elettrica (uscita USB 5V e Schuko, max 5W). Utilizzabile in contenitori da 147,2 - 184 - 220,8</p> <p>Accessorised shelf for 36e8 desk The shelf includes: - internal lighting (built-in LED, touch system, dimmable light 3000°K), - power unit (12V, 6 outputs, max 30W), - plug electric socket (USB 5V and Schuko, max 5W). Usable in storage units measuring 147,2 - 184 - 220,8</p> 	11	70,7	19,8	TER7301		
<p>**Disponibile nelle finiture Peltro steel o Titanio steel **Available in the Peltro Steel or Titanio Steel finishes</p>						
<p>Schienale vetro Glass back</p>  <p>(*) Vano singolo (**) Contenitore completo (*) Compartment (**) Full unit</p>	36,8	70,7 (*) 89,1 (*) 107,5 (*) 147,2 (**) 184 (**) 220,8 (**)	TER7409 TER7410 TER7411 TER7412 TER7413 TER7414	Vetro lucido Polished glass	Vetro opaco Matt glass	XGlass

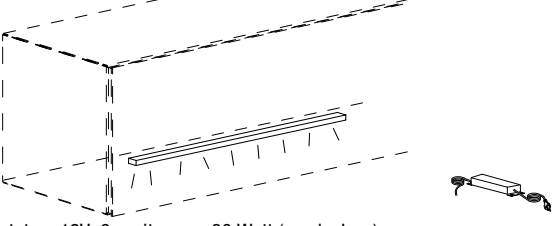
Descrizione/Description	Larghezza Width	Potenza Power	Codice Code	Alluminio Aluminium
<p>illuminazione sottopensile LED da incasso, accensione touch system, luce dimerabile 3000°K <i>Lighting under cabinet</i> <i>Recessed LEDs, touch system for switching on/off, 3000°K dimmable light</i></p>  <p>Alimentatore 12V, 6 uscite, max 30 Watt (non incluso). <i>Power supply 12V, 6 exits, max 30 Watt (not included).</i></p>				
	50	2,4 Watt	CU0634	
	75	4,1 Watt	CU0635	
	100	5,8 Watt	CU0636	
	Alimentatore Power supply	30 Watt	CU0625	

**Mensole
Shelves**

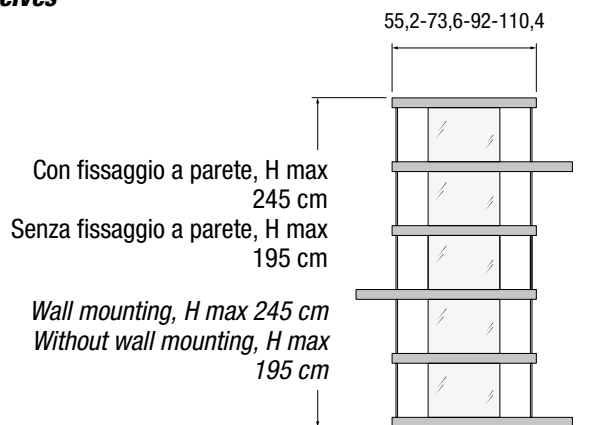

**Mensole con contenitore sospeso
Shelves with suspended unit**

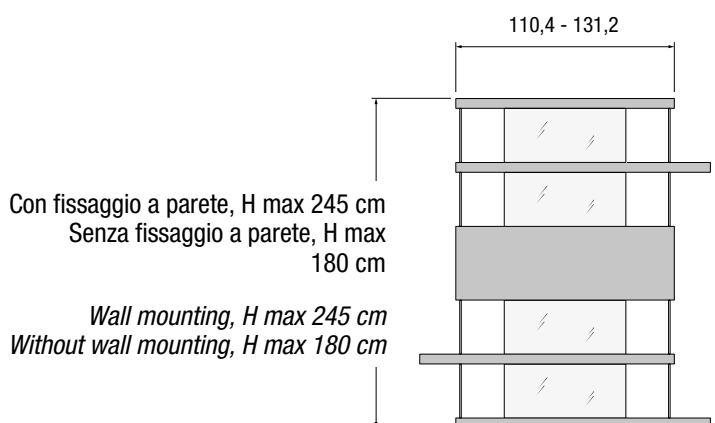
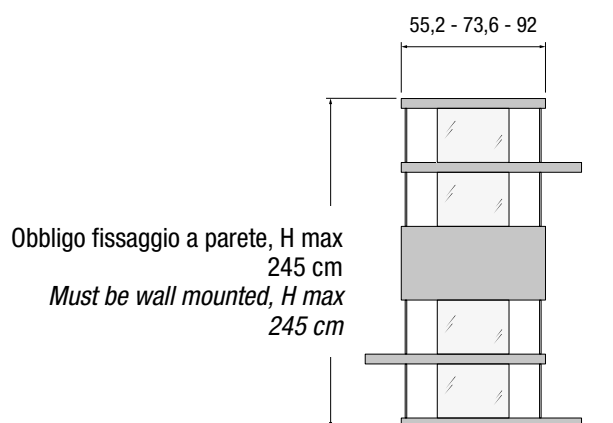

**Mensole con contenitore a terra
Shelves with floor-standing unit**

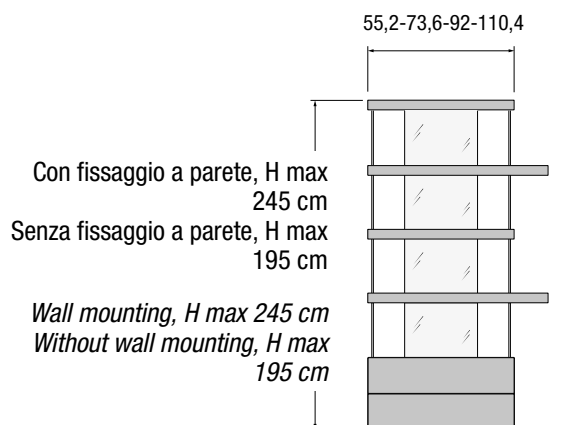

**Contenitori
Storage units**

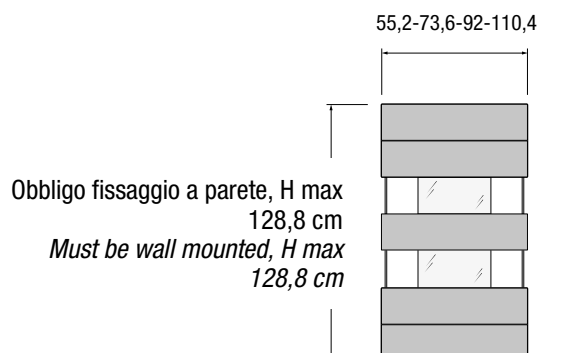

**L. 55,2 cm - 73,6 cm
W. 55,2 cm - 73,6 cm**

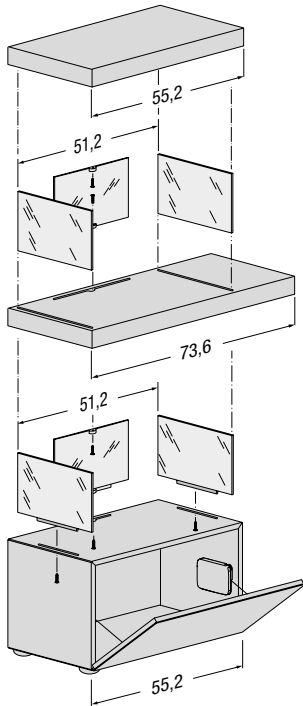

**L. 73,6 cm - 92 cm
W. 73,6 cm - 92 cm**

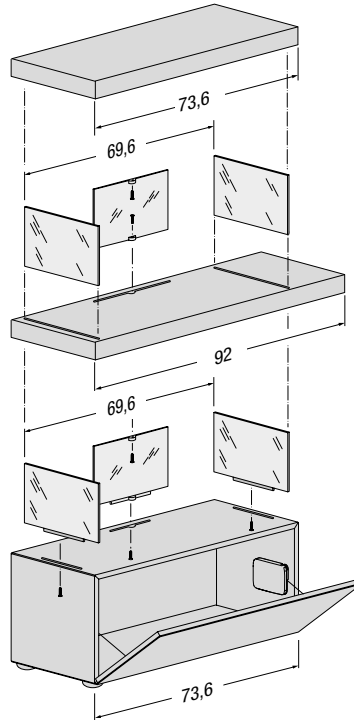

**L. 92 cm - 110,4 cm
W. 92 cm - 110,4 cm**

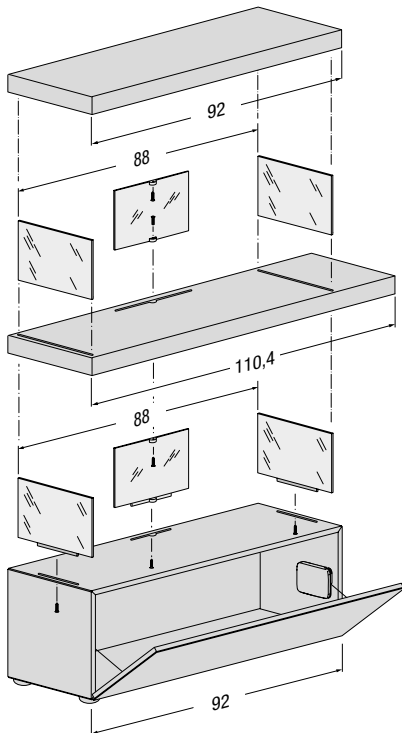

**L. 110,4 cm - 131,2 cm
W. 110,4 cm - 131,2 cm**

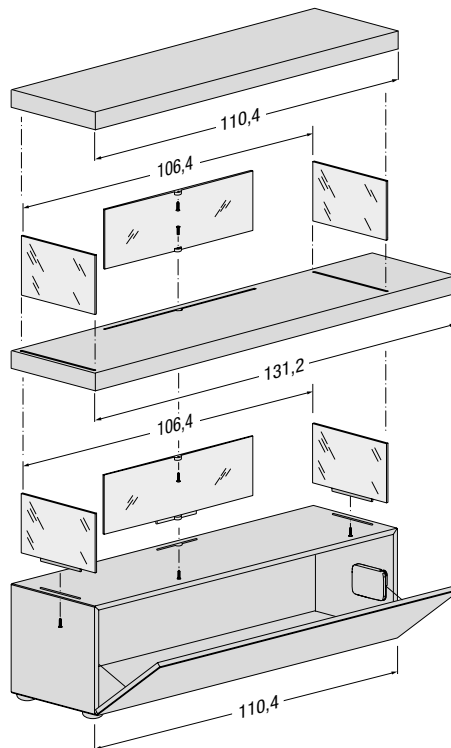

P. 40,6 AIR SET VETRI E MENSOLE//D. 40,6 AIR GLASS SET AND SHELVES

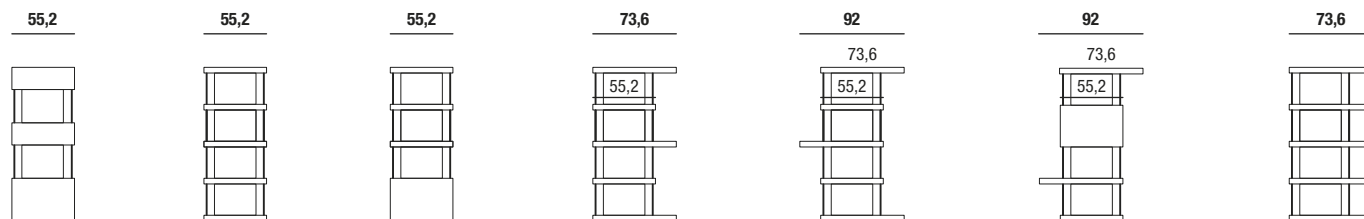

Alcuni esempi:

Examples:

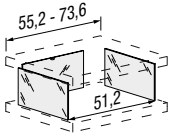
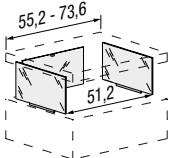
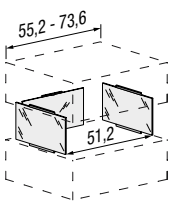
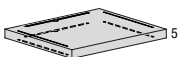
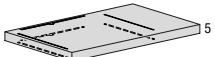

N.B: I set vetri devono avere tutti la stessa larghezza. Per mensola a sbalzo utilizzare solo la misura presente in questa pagina.

N.B: Glass sets must all have the same width. For overhanging shelves, use only the size available in this page.

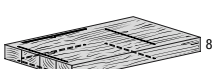
Descrizione//Description	Profondità Depth	Altezza vetri Glass height	Codice Code	Vetro extra-chiaro Extra-clear glass	Vetro fumè* Smoked glass*
Set vetri mensola - mensola <i>Glass set between 2 shelves</i> 	40,6	13,8	AIR8801		
		18,4	AIR8321		
		23	AIR8811		
		27,6	AIR8821		
		32,2	AIR8341		
		36,8	AIR8351		
Set vetri mensola - contenitore <i>Glass set between a shelf and a storage unit</i> 	40,6	13,8	AIR8802		
		18,4	AIR8322		
		23	AIR8812		
		27,6	AIR8822		
		32,2	AIR8342		
		36,8	AIR8352		
Set vetri contenitore - contenitore <i>Glass set between storage units</i> 	40,6	13,8	AIR8800		
		18,4	AIR8320		
		23	AIR8810		
		27,6	AIR8820		
		32,2	AIR8340		
		36,8	AIR8350		
Coperchio, fondo o mensola reversibile <i>Top, bottom or reversible shelf</i> 	Larghezza Width	Profondità Depth	Altezza Height	Codice Code	Laccato Lacquered
	55,2	40,6	5	AIR316	
Coperchio, fondo o mensola reversibile <i>Top, bottom or reversible shelf</i> 	Larghezza Width	Profondità Depth	Altezza Height	Codice Code	Laccato Lacquered
	73,6	40,6	5	AIR317	
Coperchio, fondo o mensola reversibile <i>Top, bottom or reversible shelf</i> 	Larghezza Width	Profondità Depth	Altezza Height	Codice Code	Wildwood
	55,2	40,6	8	AIW019	
Coperchio, fondo o mensola reversibile <i>Top, bottom or reversible shelf</i> 	Larghezza Width	Profondità Depth	Altezza Height	Codice Code	Wildwood
	73,6	40,6	8	AIW020	

P. 40,6 AIR CONTENITORI//D. 40,6 AIR STORAGE UNITS

Descrizione Description	L/W	P/D	A/H	Codice Code	Frontale//Front									
					Laccato Lacquered		Vetro lucido Polished glass		Vetro opaco Matt glass		XGlass		Wildwood	
Struttura laccata o Rovere Gentile//Lacquered or Gentle oak structure														
Contenitore a ribalta <i>Flap storage unit</i>														
	55,2	40,6	18,4	AI103R										
Contenitore 1 cassetto <i>Storage unit w/1 drawer</i>														
	55,2	40,6	18,4	AI123										
Contenitore a ribalta <i>Flap storage unit</i>														
	55,2	40,6	27,6	AI143R										
Contenitore cestone <i>Large drawer storage unit</i>														
	55,2	40,6	27,6	AI163										
Contenitore a ribalta <i>Flap storage unit</i>														
	55,2	40,6	36,8	AI113R										
Contenitore cestone <i>Large drawer storage unit</i>														
	55,2	40,6	36,8	AI143										
Contenitore 2 cassetti <i>Storage unit w/2 drawers</i>														
	55,2	40,6	36,8	AI133										
Contenitore 3 cassetti <i>Storage unit w/3 drawers</i>														
	55,2	40,6	55,2	AI153										
Contenitore anta battente <i>Hinged door storage unit</i>														
	55,2	40,6	55,2	AI123B									-	-
Contenitore anta battente <i>Hinged door storage unit</i>														
	55,2	40,6	73,6	AI133B									-	-

P. 40,6 AIR SET VETRI E MENSOLE//D. 40,6 AIR GLASS SET AND SHELVES

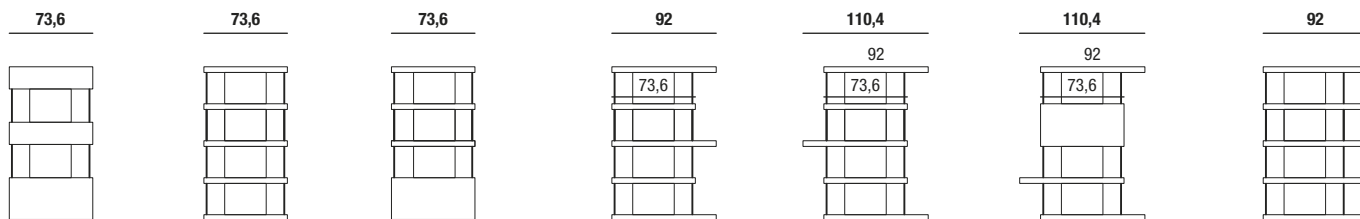

Alcuni esempi:

Examples:

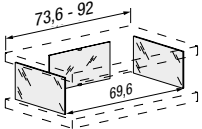
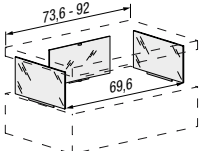
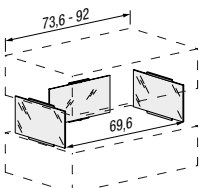
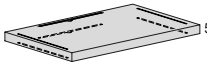
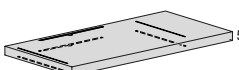

N.B: I set vetri devono avere tutti la stessa larghezza. Per mensole a sbalzo utilizzare solo la misura presente in questa pagina.

N.B: Glass sets must all have the same width. For overhanging shelves, use only the size available in this page.

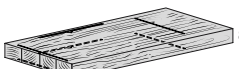
Descrizione//Description	Profondità Depth	Altezza vetri Glass height	Codice Code	Vetro extra-chiaro Extra-clear glass	Vetro fumè* Smoked glass*
Set vetri mensola - mensola <i>Glass set between 2 shelves</i> 	40,6	18,4	AIR8321		
		23	AIR8811		
		27,6	AIR8821		
		32,2	AIR8341		
		36,8	AIR8351		
Set vetri mensola - contenitore <i>Glass set between a shelf and a storage unit</i> 	40,6	18,4	AIR8322		
		23	AIR8812		
		27,6	AIR8822		
		32,2	AIR8342		
		36,8	AIR8352		
Set vetri contenitore - contenitore <i>Glass set between storage units</i> 	40,6	18,4	AIR8320		
		23	AIR8810		
		27,6	AIR8820		
		32,2	AIR8340		
		36,8	AIR8350		
Coperchio, fondo o mensola reversibile <i>Top, bottom or reversible shelf</i> 	Larghezza Width	Profondità Depth	Altezza Height	Codice Code	Laccato Lacquered
	73,6	40,6	5	AIR317	
Coperchio, fondo o mensola reversibile <i>Top, bottom or reversible shelf</i> 	Larghezza Width	Profondità Depth	Altezza Height	Codice Code	Laccato Lacquered
	92	40,6	5	AIR318	
Coperchio, fondo o mensola reversibile <i>Top, bottom or reversible shelf</i> 	Larghezza Width	Profondità Depth	Altezza Height	Codice Code	Wildwood
	73,6	40,6	8	AIW020	
Coperchio, fondo o mensola reversibile <i>Top, bottom or reversible shelf</i> 	Larghezza Width	Profondità Depth	Altezza Height	Codice Code	Wildwood
	92	40,6	8	AIW021	

P. 40,6 AIR CONTENITORI//D. 40,6 AIR STORAGE UNITS

Descrizione Description	L/W	P/D	A/H	Codice Code	Frontale//Front									
					Laccato Lacquered		Vetro lucido Polished glass		Vetro opaco Matt glass		XGlass		Wildwood	
Struttura laccata o Rovere Gentile//Lacquered or Gentle oak structure														
Contenitore a ribalta Flap storage unit														
	73,6	40,6	18,4	AI104R										
Contenitore 1 cassetto Storage unit w/1 drawer														
	73,6	40,6	18,4	AI124										
Contenitore a ribalta Flap storage unit														
	73,6	40,6	27,6	AI144R										
Contenitore cestone Large drawer storage unit														
	73,6	40,6	27,6	AI164										
Contenitore a ribalta Flap storage unit														
	73,6	40,6	36,8	AI114R										
Contenitore cestone Large drawer storage unit														
	73,6	40,6	36,8	AI144										
Contenitore 2 cassetti Storage unit w/2 drawers														
	73,6	40,6	36,8	AI134										
Contenitore 3 cassetti Storage unit w/3 drawers														
	73,6	40,6	55,2	AI154										
Contenitore anta battente Hinged door storage unit														
	73,6	40,6	55,2	AI124B										
Contenitore anta battente Hinged door storage unit														
	73,6	40,6	73,6	AI134B										

P. 40,6 AIR SET VETRI E MENSOLE//D. 40,6 AIR GLASS SET AND SHELVES

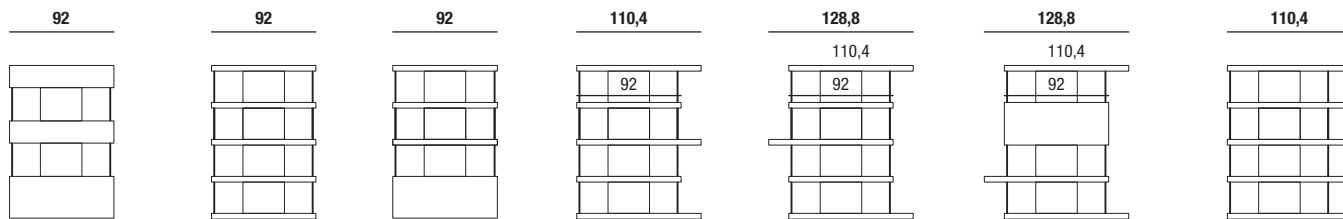

Alcuni esempi:

Examples:





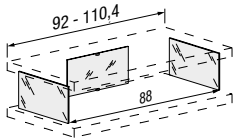
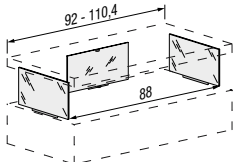
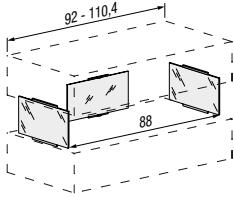
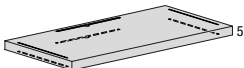
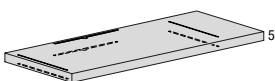













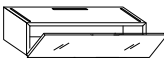
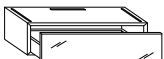

N.B: I set vetri devono avere tutti la stessa larghezza. Per mensola a sbalzo utilizzare solo la misura presente in questa pagina.

N.B: Glass sets must all have the same width. For overhanging shelves, use only the size available in this page.

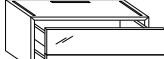
Descrizione//Description	Profondità Depth	Altezza vetri Glass height	Codice Code	Vetro extra-chiaro Extra-clear glass	Vetro fumè* Smoked glass*
Set vetri mensola - mensola <i>Glass set between 2 shelves</i> 	40,6	18,4	AIR8321		
		23	AIR8811		
		27,6	AIR8821		
		32,2	AIR8341		
		36,8	AIR8351		
Set vetri mensola - contenitore <i>Glass set between a shelf and a storage unit</i> 	40,6	18,4	AIR8322		
		23	AIR8812		
		27,6	AIR8822		
		32,2	AIR8342		
		36,8	AIR8352		
Set vetri contenitore - contenitore <i>Glass set between storage units</i> 	40,6	18,4	AIR8320		
		23	AIR8810		
		27,6	AIR8820		
		32,2	AIR8340		
		36,8	AIR8350		
Coperchio, fondo o mensola reversibile <i>Top, bottom or reversible shelf</i> 	Larghezza Width	Profondità Depth	Altezza Height	Codice Code	Laccato Lacquered
	92	40,6	5	AIR318	
Coperchio, fondo o mensola reversibile <i>Top, bottom or reversible shelf</i> 	Larghezza Width	Profondità Depth	Altezza Height	Codice Code	Laccato Lacquered
	110,4	40,6	5	AIR319	
Coperchio, fondo o mensola reversibile <i>Top, bottom or reversible shelf</i> 	Larghezza Width	Profondità Depth	Altezza Height	Codice Code	Wildwood
	92	40,6	8	AIW021	
Coperchio, fondo o mensola reversibile <i>Top, bottom or reversible shelf</i> 	Larghezza Width	Profondità Depth	Altezza Height	Codice Code	Wildwood
	110,4	40,6	8	AIW022	

P. 40,6 AIR CONTENITORI//D. 40,6 AIR STORAGE UNITS

Descrizione Description	L/W	P/D	A/H	Codice Code	Frontale//Front									
					Laccato Lacquered		Vetro lucido Polished glass		Vetro opaco Matt glass		XGlass		Wildwood	
Struttura laccata o Rovere Gentile//Lacquered or Gentle oak structure														
Contenitore a ribalta Flap storage unit														
	92	40,6	18,4	AI106R										
Contenitore 1 cassetto Storage unit w/1 drawer														
	92	40,6	18,4	AI126										
Contenitore a ribalta Flap storage unit														
	92	40,6	27,6	AI146R										
Contenitore cestone Large drawer storage unit														
	92	40,6	27,6	AI166										
Contenitore a ribalta Flap storage unit														
	92	40,6	36,8	AI116R										
Contenitore cestone Large drawer storage unit														
	92	40,6	36,8	AI146										
Contenitore 2 cassetti Storage unit w/2 drawers														
	92	40,6	36,8	AI136										
Contenitore 3 cassetti Storage unit w/3 drawers														
	92	40,6	55,2	AI156										
Contenitore anta battente Hinged door storage unit														
	92	40,6	55,2	AI126B									-	-
Contenitore anta battente Hinged door storage unit														
	92	40,6	73,6	AI136B									-	-

P. 40,6 AIR SET VETRI E MENSOLE//D. 40,6 AIR GLASS SET AND SHELVES

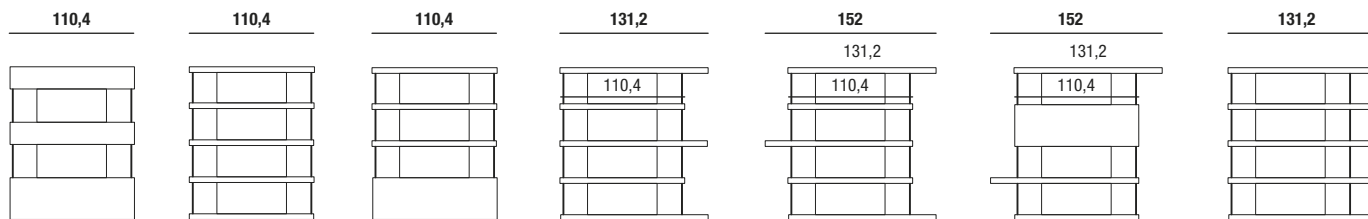

Alcuni esempi:

Examples:

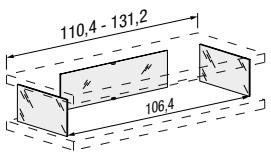
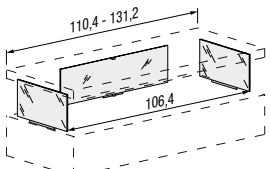
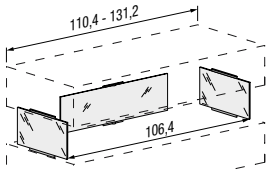
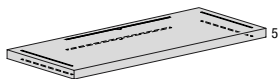
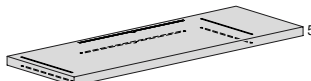

N.B: I set vetri devono avere tutti la stessa larghezza. Per mensole a sbalzo utilizzare solo la misura presente in questa pagina.

N.B: Glass sets must all have the same width. For overhanging shelves, use only the size available in this page.

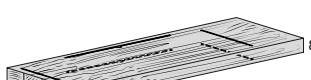
Descrizione//Description	Profondità Depth	Altezza vetri Glass height	Codice Code	Vetro extra-chiaro Extra-clear glass	Vetro fumè* Smoked glass*
Set vetri mensola - mensola <i>Glass set between 2 shelves</i> 	40,6	18,4	AIR8011		
		23	AIR8021		
		27,6	AIR8031		
		32,2	AIR8041		
		36,8	AIR8071		
Set vetri mensola - contenitore <i>Glass set between a shelf and a storage unit</i> 	40,6	18,4	AIR8012		
		23	AIR8022		
		27,6	AIR8032		
		32,2	AIR8042		
		36,8	AIR8072		
Set vetri contenitore - contenitore <i>Glass set between storage units</i> 	40,6	18,4	AIR8010		
		23	AIR8020		
		27,6	AIR8030		
		32,2	AIR8040		
		36,8	AIR8070		
Coperchio, fondo o mensola reversibile <i>Top, bottom or reversible shelf</i> 	Larghezza Width	Profondità Depth	Altezza Height	Codice Code	Laccato Lacquered
	110,4	40,6	5	AIR319	
Coperchio, fondo o mensola reversibile <i>Top, bottom or reversible shelf</i> 	Larghezza Width	Profondità Depth	Altezza Height	Codice Code	Laccato Lacquered
	131,2	40,6	5	AIR320	
Coperchio, fondo o mensola reversibile <i>Top, bottom or reversible shelf</i> 	Larghezza Width	Profondità Depth	Altezza Height	Codice Code	Wildwood
	110,4	40,6	8	AIW022	
Coperchio, fondo o mensola reversibile <i>Top, bottom or reversible shelf</i> 	Larghezza Width	Profondità Depth	Altezza Height	Codice Code	Wildwood
	131,2	40,6	8	AIW023	

P. 40,6 AIR CONTENITORI//D. 40,6 AIR STORAGE UNITS

Descrizione Description	L/W	P/D	A/H	Codice Code	Frontale//Front									
					Laccato Lacquered		Vetro lucido Polished glass		Vetro opaco Matt glass		XGlass		Wildwood	
Struttura laccata o Rovere Gentile//Lacquered or Gentle oak structure														
Contenitore a ribalta <i>Flap storage unit</i>														
	110,4	40,6	18,4	AI105R										
Contenitore 1 cassetto <i>Storage unit w/1 drawer</i>														
	110,4	40,6	18,4	AI125										
Contenitore a ribalta <i>Flap storage unit</i>														
	110,4	40,6	27,6	AI145R										
Contenitore cestone <i>Large drawer storage unit</i>														
	110,4	40,6	27,6	AI165										
Contenitore a ribalta <i>Flap storage unit</i>														
	110,4	40,6	36,8	AI115R										
Contenitore cestone <i>Large drawer storage unit</i>														
	110,4	40,6	36,8	AI145										
Contenitore 2 cassetti <i>Storage unit w/2 drawers</i>														
	110,4	40,6	36,8	AI135										
Contenitore 3 cassetti <i>Storage unit w/3 drawers</i>														
	110,4	40,6	55,2	AI155										
Contenitore anta battente <i>Hinged door storage unit</i>														
	110,4	40,6	55,2	AI125B									-	-
Contenitore anta battente <i>Hinged door storage unit</i>														
	110,4	40,6	73,6	AI135B									-	-

P. 51 AIR SET VETRI//D. 51 AIR GLASS SET

Alcuni esempi:

Examples:

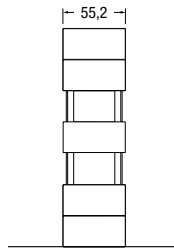

Descrizione//Description	Profondità Depth	Altezza vetri Glass height	Codice Code	Vetro extra-chiaro Extra-clear glass	Vetro fumè* Smoked glass*
Set vetri contenitore - contenitore <i>Glass set between storage units</i> 	51	18,4	AIR8360		
		25	AIR8370		
		32,2	AIR8380		
		36,8	AIR8390		

P. 51 AIR CONTENITORI//D. 51 AIR STORAGE UNITS

Descrizione Description	L/W	P/D	A/H	Codice Code	Frontale//Front									
					Laccato Lacquered		Vetro lucido Polished glass		Vetro opaco Matt glass		XGlass		Wildwood	
Struttura laccata o Rovere Gentile//Lacquered or Gentle oak structure														
Contenitore a ribalta <i>Flap storage unit</i>														
	55,2	51	18,4	AI303R										
Contenitore 1 cassetto <i>Storage unit w/1 drawer</i>														
	55,2	51	18,4	AI323										
Contenitore a ribalta <i>Flap storage unit</i>														
	55,2	51	27,6	AI343R										
Contenitore cestone <i>Large drawer storage unit</i>														
	55,2	51	27,6	AI363										
Contenitore a ribalta <i>Flap storage unit</i>														
	55,2	51	36,8	AI313R										
Contenitore cestone <i>Large drawer storage unit</i>														
	55,2	51	36,8	AI343										
Contenitore 2 cassetti <i>Storage unit w/2 drawers</i>														
	55,2	51	36,8	AI333										
Contenitore 3 cassetti <i>Storage unit w/3 drawers</i>														
	55,2	51	55,2	AI353										

P. 51 AIR SET VETRI//D. 51 AIR GLASS SET

Alcuni esempi:

Examples:

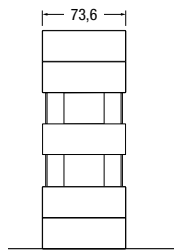

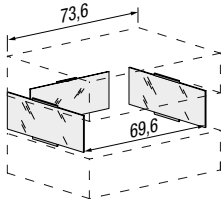
Descrizione//Description	Profondità Depth	Altezza vetri Glass height	Codice Code	Vetro extra-chiaro Extra-clear glass	Vetro fumè* Smoked glass*
Set vetri contenitore - contenitore <i>Glass set between storage units</i> 	51	18,4	AIR8360		
		25	AIR8370		
		32,2	AIR8380		
		36,8	AIR8390		

P. 51 AIR CONTENITORI//D. 51 AIR STORAGE UNITS

Descrizione Description	L/W	P/D	A/H	Codice Code	Frontale//Front									
					Laccato Lacquered		Vetro lucido Polished glass		Vetro opaco Matt glass		XGlass		Wildwood	
Struttura laccata o Rovere Gentile//Lacquered or Gentle oak structure														
Contenitore a ribalta <i>Flap storage unit</i>														
	73,6	51	18,4	AI304R										
Contenitore vasistas <i>Top-hung storage unit</i>														
	73,6	51	18,4	AI304V										
Contenitore 1 cassetto <i>Storage unit w/1 drawer</i>														
	73,6	51	18,4	AI324										
Contenitore a ribalta <i>Flap storage unit</i>														
	73,6	51	27,6	AI344R										
Contenitore cestone <i>Large drawer storage unit</i>														
	73,6	51	27,6	AI364										
Contenitore a ribalta <i>Flap storage unit</i>														
	73,6	51	36,8	AI314R										
Contenitore vasistas <i>Top-hung storage unit</i>														
	73,6	51	36,8	AI314V										
Contenitore cestone <i>Large drawer storage unit</i>														
	73,6	51	36,8	AI344										
Contenitore 2 cassetti <i>Storage unit w/2 drawers</i>														
	73,6	51	36,8	AI334										
Contenitore 3 cassetti <i>Storage unit w/3 drawers</i>														
	73,6	51	55,2	AI354										

P. 51 AIR SET VETRI//D. 51 AIR GLASS SET

Alcuni esempi:

Examples:

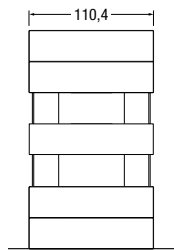

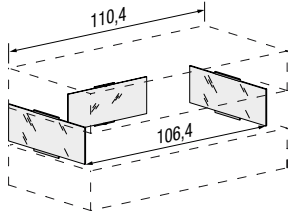
Descrizione//Description	Profondità Depth	Altezza vetri Glass height	Codice Code	Vetro extra-chiaro Extra-clear glass	Vetro fumè* Smoked glass*
Set vetri contenitore - contenitore <i>Glass set between storage units</i> 	51	18,4	AIR8120		
		25	AIR8300		
		32,2	AIR8310		
		36,8	AIR8180		

P. 51 AIR CONTENITORI//D. 51 AIR STORAGE UNITS

Descrizione Description	L/W	P/D	A/H	Codice Code	Frontale//Front									
					Laccato Lacquered		Vetro lucido Polished glass		Vetro opaco Matt glass		XGlass		Wildwood	
Struttura laccata o Rovere Gentile//Lacquered or Gentle oak structure														
Contenitore a ribalta <i>Flap storage unit</i>														
	110,4	51	18,4	AI305R										
Contenitore vasistas <i>Top-hung storage unit</i>														
	110,4	51	18,4	AI305V										
Contenitore 1 cassetto <i>Storage unit w/1 drawer</i>														
	110,4	51	18,4	AI325										
Contenitore a ribalta <i>Flap storage unit</i>														
	110,4	51	27,6	AI345R										
Contenitore cestone <i>Large drawer storage unit</i>														
	110,4	51	27,6	AI365										
Contenitore a ribalta <i>Flap storage unit</i>														
	110,4	51	36,8	AI315R										
Contenitore vasistas <i>Top-hung storage unit</i>														
	110,4	51	36,8	AI315V										
Contenitore cestone <i>Large drawer storage unit</i>														
	110,4	51	36,8	AI345										
Contenitore 2 cassetti <i>Storage unit w/2 drawers</i>														
	110,4	51	36,8	AI335										
Contenitore 3 cassetti <i>Storage unit w/3 drawers</i>														
	110,4	51	55,2	AI355										

Laccato

EN Lacquered / ES Lacado / FR Laqué / DE Lackiert

Solidità, rigore, rassicurante perfezione formale e accessibilità: il laccato è una tavolozza creativa in cui funzionalità e colori realizzano la superficie visiva del design. La laccatura è realizzata con prodotti all'acqua privi di solventi evitando così l'emissione di sostanze organiche volatili nocive nell'ambiente.

Solidity, rigour, reassuring formal perfection and accessibility: lacquer is a creative palette where functionality and colour create visual surfaces with a design sensibility. LAGO lacquer is made with solvent-free, water-based products, thus avoiding the emission of noxious, volatile organic substances in the environment.

Solidez, rigor, tranquilizadora perfección formal y accesibilidad: el lacado es una paleta creativa en donde la funcionalidad y los colores hacen realidad la superficie visual del diseño. El proceso de lacado se realiza con productos acuosos que no contienen solventes, evitando así la emisión al medio ambiente de sustancias orgánicas volátiles nocivas.

Solidité, rigueur, rassurante perfection formelle et accessibilité: le laqué est une palette créative dans laquelle fonctionnalités et couleurs créent la surface visuelle du design. La finition laquée est réalisée avec des produits hydriques sans solvants qui évitent l'émission de composés organiques volatils nocifs pour l'environnement.

Haltbarkeit, Geradlinigkeit, formelle beruhigende Perfektion: Die Farblacke sind Teil einer kreativen Farbpalette, in der Funktionalität und Farben die visuelle Oberfläche des Designs verwirklichen. Der Lackanstrich wird mit Produkten durchgeführt, die Wasser enthalten und lösungsmittelfrei sind, um so das Entweichen von schädlichen, organischen Stoffen in die Umwelt zu vermeiden.



La rappresentazione dei colori ha valore indicativo / The colour representation is indicative / La representación de los colores tiene valor indicativo / La représentation des couleurs est indicative / Die abgebildeten Farben können vom Original abweichen.

Vetro lucido

EN Polished glass / ES Cristal brillante / FR Verre brillant / DE Glas poliert

Il vetro LAGO cattura lo sguardo con una nuova esperienza del colore, reso vivo, profondo e mutevole al variare delle condizioni della luce. Rigorosamente perfetto, mantiene inalterata attraverso il tempo la propria bellezza. Il vetro ha doti intrinseche di igienicità, facile da pulire in quanto non assorbe lo sporco e le macchie e temperato, ovvero trattato termicamente per ottenere una elevata resistenza all'urto, al graffio e al calore. Viene verniciato all'acqua ed è un materiale riciclabile al 100%.

LAGO glass captures the eye with a new experience of colour, made brilliant, deep and changeable according to light conditions. Rigorously perfect, it preserves its beauty unaltered over time. LAGO glass has intrinsic hygienic properties, it is easy to clean since it does not absorb dirt or stains and it is tempered, that is to say temperature-treated in order to obtain higher resistance to shocks, scratches and heat. It is painted with water-based colour and is a 100% recyclable material.

El vidrio LAGO cautiva la mirada con una nueva forma de vivir el color, vuelto vivo, profundo y cambiante al variar las condiciones de luz. Rigorosamente perfecto, mantiene inalterada en el tiempo su belleza. El vidrio tiene características intrínsecas que lo hacen un material limpio: es fácil de lavar ya que no absorbe la suciedad ni las manchas, y con el templado es tratado térmicamente para obtener una alta resistencia a los golpes, las ralladuras y el calor. Está barnizado al agua y es un material 100% reciclable.

Le verre LAGO accroche le regard avec une nouvelle expérience de la couleur, rendue vive, profonde et changeante en fonction des variations lumineuses. Rigoureusement parfait, il conserve une beauté inaltérée à travers le temps. Le verre a des qualités hygiéniques intrinsèques: il est facile à nettoyer, car il n'absorbe ni la saleté ni les taches, et est trempé, c'est-à-dire traité thermiquement pour renforcer sa résistance aux chocs, aux rayures et à la chaleur. Verni à l'eau, ce matériau est 100 % recyclable.

Das LAGO-Glas lenkt den Blick mit einem neuen Farberlebnis auf sich, das sich Stunde um Stunde mit den Verhältnissen des Lichts als lebendig, tiefgründig und veränderbar erweist. Auf perfekte Art und Weise behält es strengstens seine Schönheit, die sich im Laufe der Zeit kein bisschen verändert. Das Glas verfügt über die einmalige Gabe der Reinheit. Es ist leicht zu reinigen, da es keinen Schmutz und keine Flecken aufnimmt; es ist für eine höhere Resistenz Stößen, Kratzern und Hitze gegenüber temperiert bzw. wärmebehandelt. Es wird mit Farben auf Wasserbasis gestrichen und ist ein 100%ig recyclefähiges Material.



La rappresentazione dei colori ha valore indicativo / The colour representation is indicative / La representación de los colores tiene valor indicativo / La représentation des couleurs est indicative / Die abgebildeten Farben können vom Original abweichen.

Vetro opaco

EN Matt glass / ES Cristal mate / FR Verre mat / DE Glas satiniert

Grazie a un processo di acidatura delle lastre, il vetro opaco LAGO crea nuovi linguaggi compositivi mescolando la perfezione tattile e formale di questo materiale con un effetto visivo sorprendente. Più delicato del vetro lucido ha doti di igienicità ed è temperato, ovvero trattato termicamente per ottenere una elevata resistenza all'urto, al graffio e al calore. Il vetro viene verniciato all'acqua ed è un materiale riciclabile al 100%.

Thanks to an acidizing process, LAGO opaque glass creates new compositional languages, mixing the tactile and formal perfection of this material with a surprising visual effect. More delicate than shiny glass, it has hygienic properties and is tempered, that is to say temperature-treated in order to obtain higher resistance to shocks, scratches and heat. LAGO opaque glass is painted with water-based colour and is a 100% recyclable material.

Gracias a un proceso de acidificación de las láminas, el vidrio opaco LAGO crea nuevos lenguajes compositivos mezclando la perfección táctil y formal de este material con un efecto visual sorprendente. Más delicado que el vidrio brillante, tiene cualidades higiénicas y está templado, es decir tratado térmicamente para obtener una alta resistencia a los golpes, las ralladuras y el calor. El vidrio está barnizado al agua y es un material 100% reciclable.

Grâce à un procédé de traitement à l'acide des plaques, le verre opaque LAGO crée de nouveaux langages de composition, en mêlant la perfection tactile et formelle de ce matériau avec un effet visuel saisissant. Plus délicat que le verre poli, il est hygiénique et trempé, c'est-à-dire traité thermiquement pour une meilleure résistance au chocs, aux rayures et à la chaleur. Ce verre verni à l'eau est un matériau 100 % recyclable.

Dank einer Säurebehandlung der Scheiben, erfindet das Mattglas von LAGO eine neue Kompositionssprache, indem es die tastbare und formale Perfektion dieses Materials mit einem offensichtlichen, erstaunlichen Effekt vereint. Es ist delikater als transparentes Glas und verfügt über hygienische Eigenschaften; ist für eine höhere Resistenz Stößen, Kratzern und Hitze gegenüber temperiert bzw. wärmebehandelt. Es wird mit Farben auf Wasserbasis gestrichen und ist ein 100%ig recyclefähiges Material.



La rappresentazione dei colori ha valore indicativo / The colour representation is indicative / La representación de los colores tiene valor indicativo / La représentation des couleurs est indicative / Die abgebildeten Farben können vom Original abweichen.

Vetro Metal lucido e opaco

^{EN} Polished and matt Metal Glass / ^{ES} Cristal Metal brillante es mate / ^{FR} Verre Métal brillant et mat / ^{DE} Glas Metal poliert und satiniert

Tre colorazioni dai riflessi metallici caldi e cangianti avvolgono le superfici in modo uniforme, donando dinamismo e luminosità al prodotto nelle diverse finiture, lucida e opaca. Colori vivi che producono eleganti effetti visivi al variare della luce naturale e domestica. Realizzati con prodotti all'acqua privi di solventi, garantiscono igienicità e resistenza nel tempo grazie alle proprietà intrinseche del vetro.

Three shimmering metallic colours dominate the surface evenly, creating a bright, warm and dynamic look, available in a range of matt and polished finishes. Vivid colours create elegant visuals as the light changes both indoors and outdoors. Produced using solvent-free, water-based products, your furniture is hygienic and durable over time, thanks to the intrinsic qualities of glass.

Tres coloraciones de reflejos metálicos cálidos y cambiantes envuelven las superficies de manera uniforme, dando dinamismo y luminosidad al producto en los diferentes acabados brillo y mate. Colores vivos que producen elegantes efectos visuales al variar la luz natural y doméstica. Realizados con productos al agua sin disolventes, garantizan higiene y resistencia a lo largo del tiempo gracias a las propiedades intrínsecas del cristal.

Trois coloris aux reflets métalliques chauds et chatoyants enveloppent les surfaces de manière uniforme, tout en donnant dynamisme et luminosité au produit dans les différentes finitions, brillantes et mates. Des couleurs vives qui produisent d'élégants effets visuels selon la variation de la lumière naturelle et domestique. Réalisés avec des produits à l'eau sans solvants, ils garantissent hygiène et résistance dans le temps grâce aux propriétés intrinsèques du verre.

Drei Farben mit warmen, changierenden Metallic-Reflexen umhüllen die Oberflächen gleichmäßig und verleihen dem Produkt in den verschiedenen Ausführungen – glänzend und matt – Dynamik und Helligkeit. Lebendige Farben, die bei wechselndem natürlichem und häuslichem Licht elegante visuelle Effekte erzeugen. Sie werden mit lösungsmittelfreien Produkten auf Wasserbasis hergestellt und garantieren dank der charakteristischen Eigenschaften von Glas Hygiene und Haltbarkeit.



CHAMPAGNE METAL

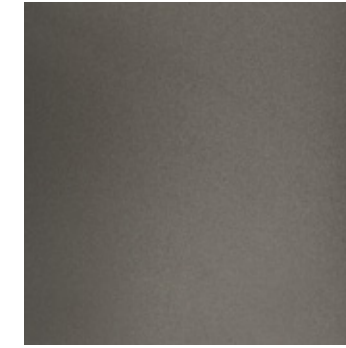

PIOMBO METAL



TUNDRA METAL

XGlass lucido e opaco

EN Polished and matt XGlass / ES XGlass brillante es mate / FR XGlass brillant et mat / DE XGlass poliert und satiniert

La rivoluzione tecnologica sta accelerando i processi di innovazione anche nel campo dei materiali, offrendo opportunità incredibili. Grazie alla digital print XGlass coniuga le qualità di un materiale nobile e prezioso come il vetro alle emozioni di molteplici materiali. Le diverse finiture, lucida e opaca, aumentano poi l'empatia con il materiale stesso. Una raffinata continuità di pattern connota le superfici dei prodotti. XGlass è una strategia innovativa anche per poter ridurre in più casi l'impatto ambientale e migliorare quello sociale.

The technological revolution is speeding up innovation and offering incredible opportunities, including in the field of materials. Using digital printing technology, XGlass combines the fine qualities of glass with the emotion of a whole range of other materials. The different finishes, available in glossy and mat, increase empathy with the material itself and a refined continuous pattern defines the surface of each piece. XGlass is also an innovative solution for reducing environmental impact in many cases and improving the social one.

La révolution technologique accélère les processus d'innovation même dans le domaine des matériaux et ouvre la voie à d'incroyables opportunités. Grâce à l'impression numérique, XGlass combine les qualités d'un matériau noble et précieux comme le verre aux émotions de plusieurs matériaux. Les diverses finitions, brillante et opaque, intensifient l'empathie avec le matériau lui-même. Cette continuité raffinée de motifs caractérise les surfaces des produits. XGlass est également une stratégie innovante qui permet de réduire, dans de nombreux cas, l'incidence environnementale et d'améliorer l'impact social.

La revolución tecnológica está acelerando los procesos de innovación en el campo de los materiales, ofreciendo oportunidades increíbles. Gracias a la impresión digital, XGlass conjuga las cualidades de un material noble y preciado como el cristal con las emociones de múltiples materiales. Los diferentes acabados, brillo y mate, aumentan también la empatía con el material mismo. Una elegante continuidad de estampados distinguen las superficies de los productos. XGlass es una estrategia innovadora también para poder reducir en más casos el impacto ambiental y mejorar el social.

Die technologische Revolution beschleunigt Innovationsprozesse auch im Bereich der Materialien und bietet unglaubliche Möglichkeiten. Dank des Digitaldrucks verbindet XGlass die Eigenschaften eines edlen und kostbaren Materials wie Glas mit den Emotionen vieler Materialien. Die verschiedenen Ausführungen, die glänzend und matt erhältlich sind, sorgen für noch mehr Begeisterung. Ein raffinierter Übergang der Muster auf der Oberflächen gibt den Produkte ihren besonderen Charakter. XGlass ist ein innovative Instrument zur Verringerung der Umweltbelastung und zur Verbesserung der sozialen Auswirkungen.

MARBLE XGLASS

Gamma completa - Complete range - Amplia gama - Gamme complète - Umfassende Palette

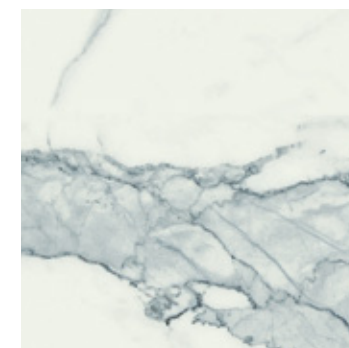

STATUARIO



PAONAZZO



CALACATTA GOLD



ONICE GRIGIO

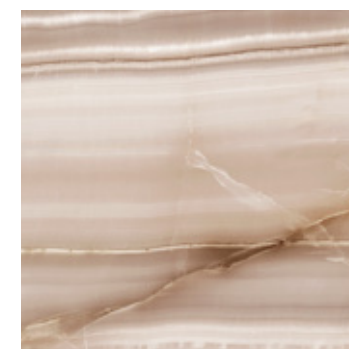

ONICE

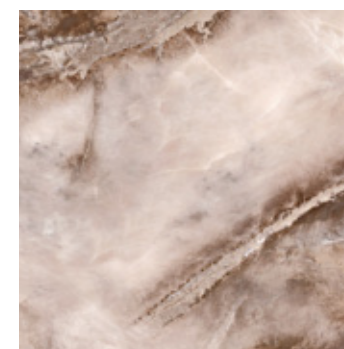

ALABASTRO

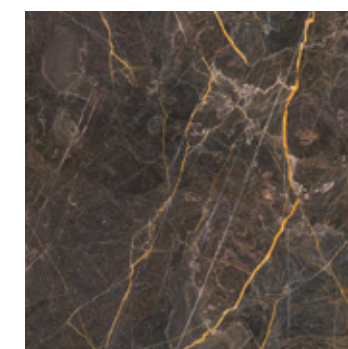

PORT SAINT LAURENT

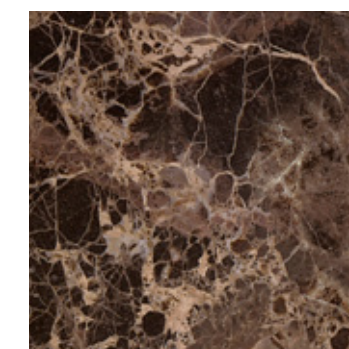

EMPERADOR



GEODE

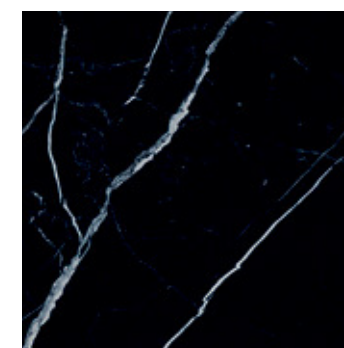

MARQUINA

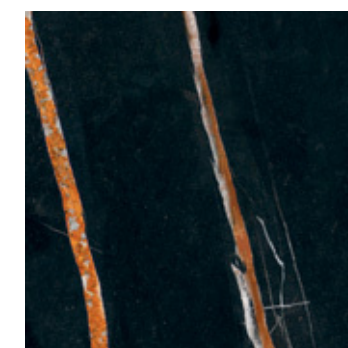

SAHARA NOIR

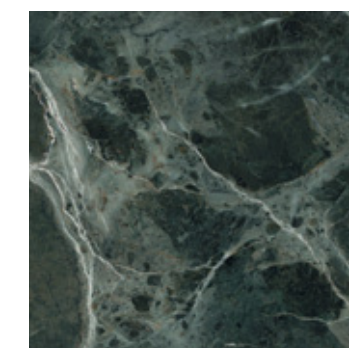

VERDE ALPI

MARBLE XGLASS

Scala 1:3 - Scale 1:3 - Escala 1:3 - Échelle 1:3 - Maßstab 1:3

3 m

2 m

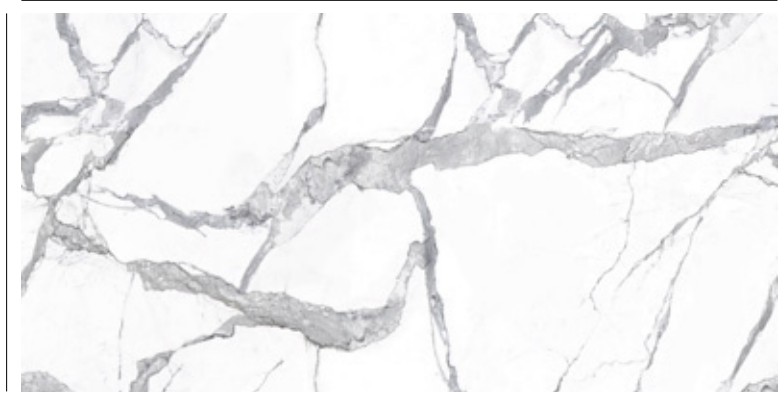

STATUARIO



PAONAZZO

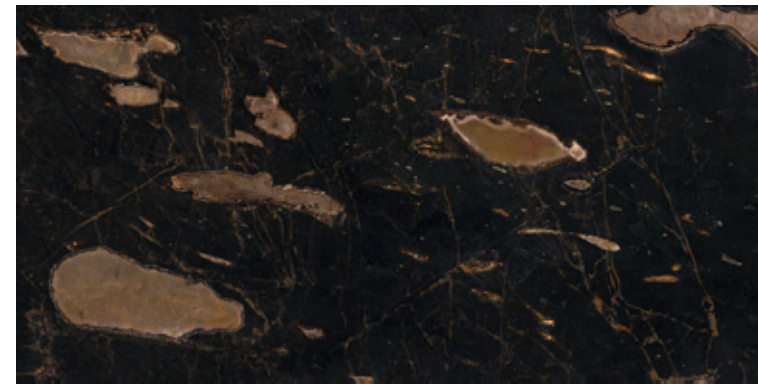

GEODE

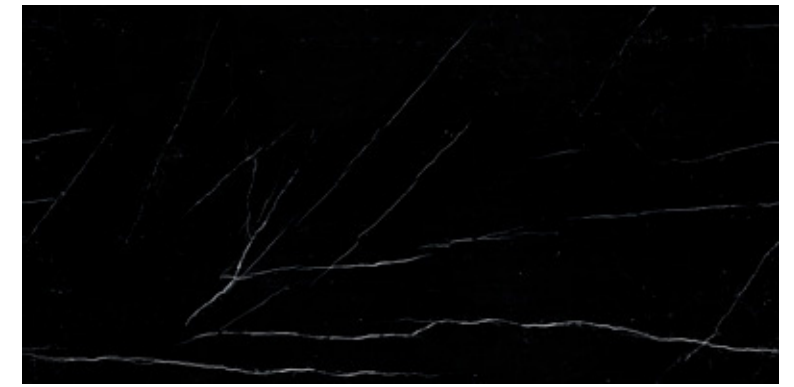

MARQUINA

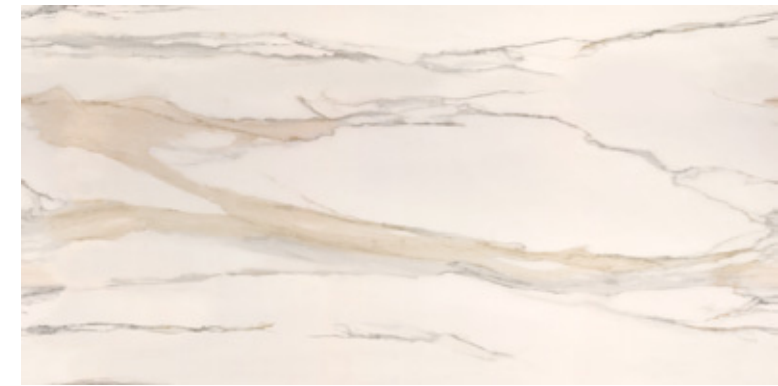

CALACATTA GOLD

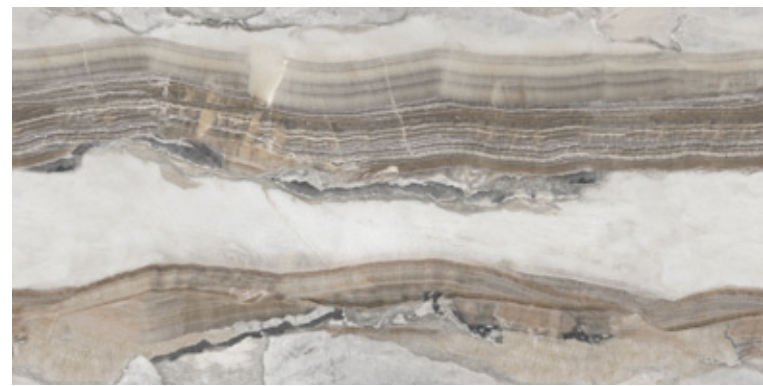

ONICE GRIGIO

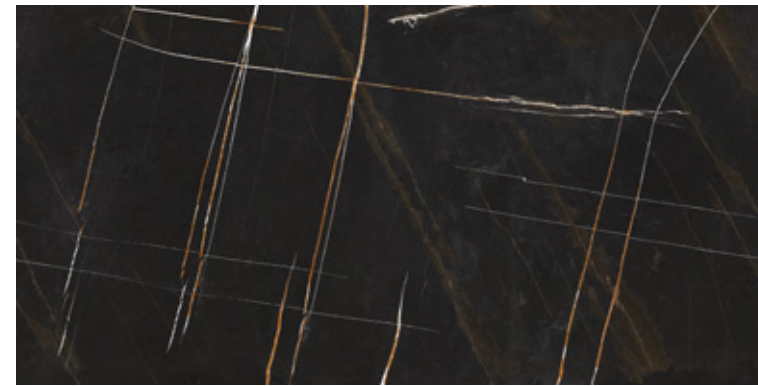

SAHARA NOIR

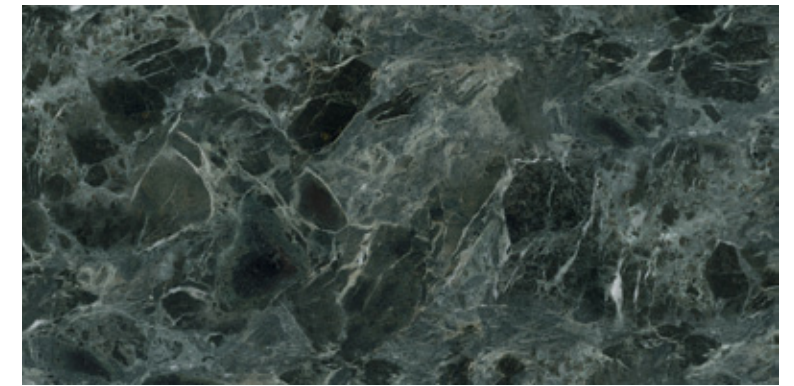

VERDE ALPI

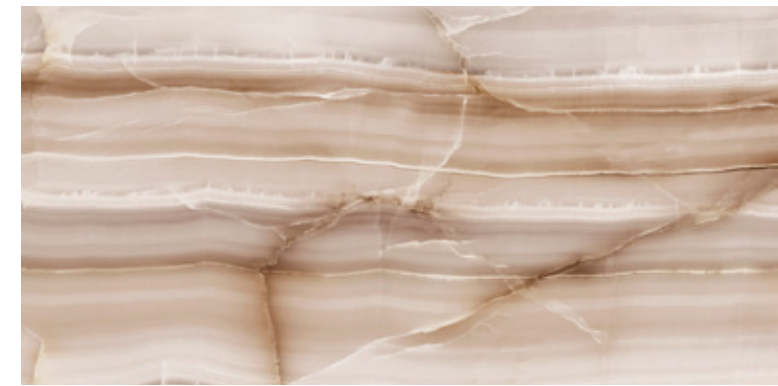

ONICE



ALABASTRO

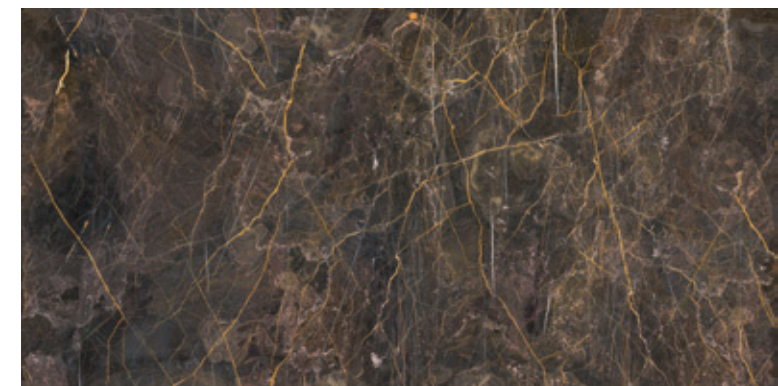

PORT SAINT LAURENT



EMPERADOR

METAL XGLASS



TITANIO

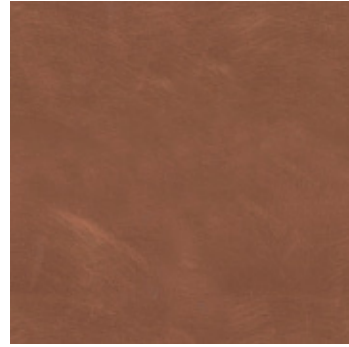

RAME

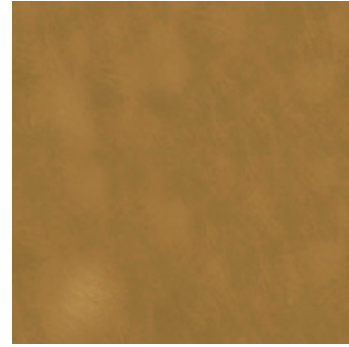

ORO



BRONZO



PELTRO

HOME COUTURE XGLASS

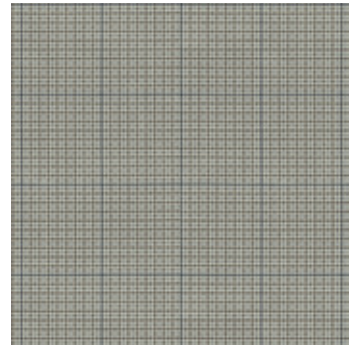

KISS WOOL

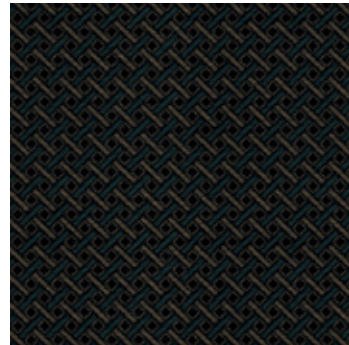

POP PANTS

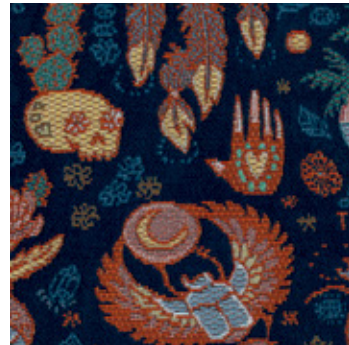

ART & CRAFT

ANIMAL ZERO XGLASS*

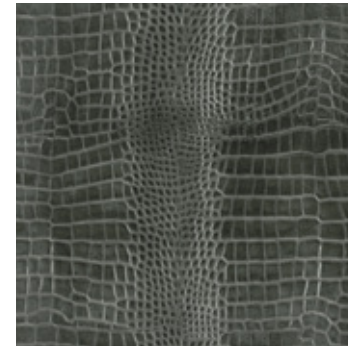

COCCODRILLO VERDE

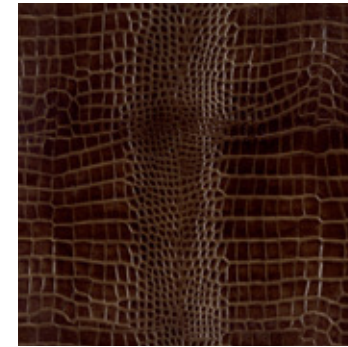

COCCODRILLO MARRONE

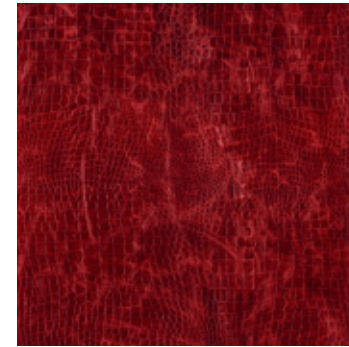

COBRA ROSSO

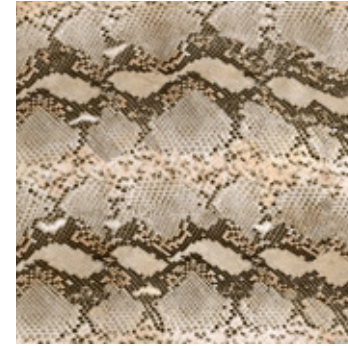

PITONE

**Disponibile solo nella versione lucida. / Available only in the polished version. / Disponible sólo en la versión brillante. / Disponible uniquement en version brillant. / Nur in der poliert Version erhältlich.*

WOOD XGLASS

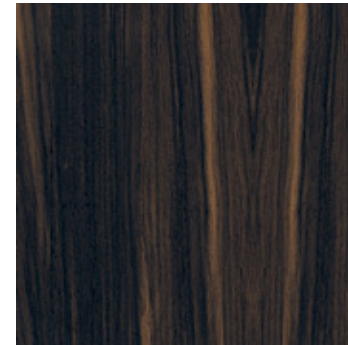

EBANO MACASSAR

Aqua

L'eleganza intrinseca del vetro opaco combinata alla sua raffinata lavorazione tridimensionale, dà vita a un materiale dalla piacevole sensazione tattile. Grazie a questa particolare tecnica decorativa del vetro, le luci trasformano le superfici, modificando anche la percezione visiva delle finiture, che spaziano dal laccato all'XGlass.

Intrinsically elegant matt glass combined with a sophisticated three-dimensional processing technique creates a pleasantly tactile material. With this special glass decoration technique, the surfaces transform in the light, altering the look of the finishes ranging from lacquer to XGlass.

L'élégance intrinsèque du verre mat, alliée à son usinage raffiné en trois dimensions, donne vie à un matériau offrant une agréable sensation tactile. Grâce à cette technique spécifique de décoration du verre, les lumières transforment les surfaces et modifient également la perception visuelle des finitions qui vont du laqué au XGlass.

La elegancia intrínseca del cristal mate combinada con su refinada elaboración tridimensional da vida a un material de agradable sensación táctil. Gracias a esta singular técnica decorativa del cristal las luces transforman las superficies, modificando también la percepción visual de los acabados, que van del lacado al XGlass.

Die inhärente Eleganz von opakem Glas schafft ein Material mit einer angenehmen Haptik. Dank dieser speziellen Glasdekorationstechnik verwandeln Lichter die Oberflächen und verändern auch die visuelle Wahrnehmung der Ausführungen, die von lackiert bis XGlass reichen.

Aqua Vetro Opaco

Aqua Matt glass / Aqua Cristal mate / Aqua Verre mat / Aqua Glas satiniert

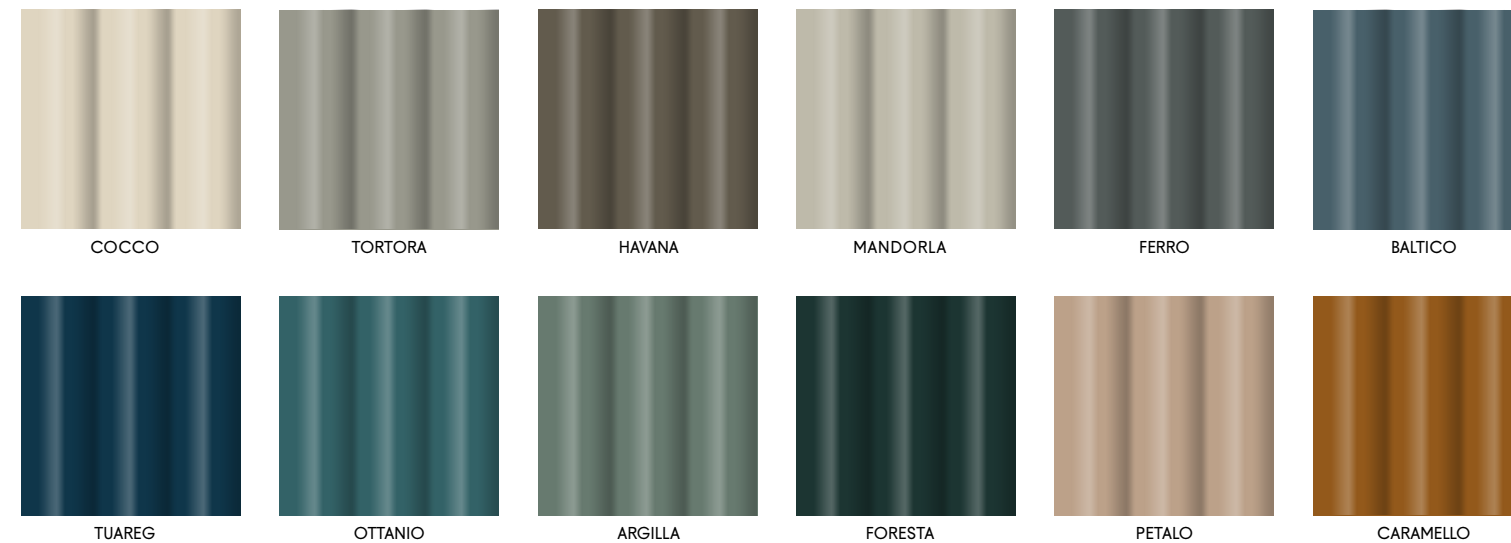

Aqua XGlass opaco

Aqua matt XGlass / Aqua XGlass mate / Aqua XGlass mat / Aqua XGlass satiniert

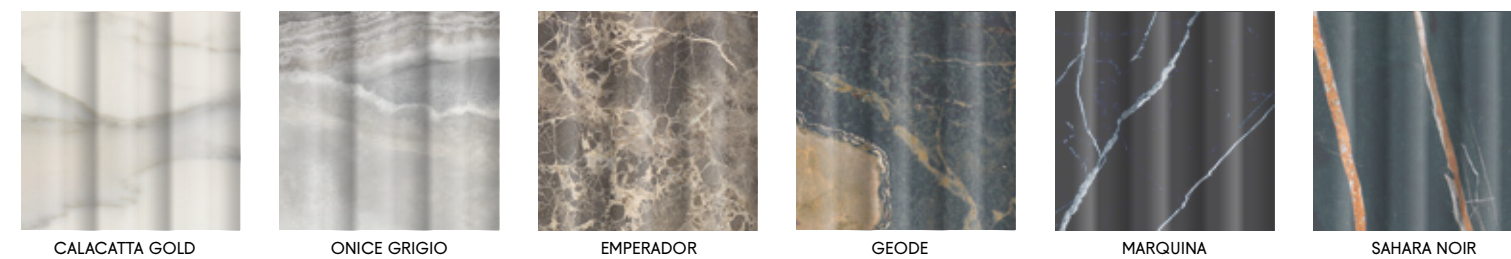

La rappresentazione dei colori ha valore indicativo / The colour representation is indicative / La representación de los colores tiene valor indicativo / La représentation des couleurs est indicative / Die abgebildeten Farben können vom Original abweichen.

Wildwood

Calore, ospitalità, senso del tempo, il legno sa essere primordiale ambasciatore di verità e, allo stesso tempo, di un lusso raffinato e tattile. Realizzato a partire da legno di rovere piallato a mano, il Wildwood è sottoposto a una lavorazione artigianale che ne esalta le naturali imperfezioni. I nodi e le fessure sono stuccati con prodotti speciali ad alta resistenza e una verniciatura protettiva limita la permeabilità della superficie ai liquidi e alle macchie.

Warmth, hospitality, a sense of time: wood is a primordial ambassador of truth and, at the same time, a refined, tactile luxury. Made with hand-planed oak, is artisanally processed to enhance its natural imperfections. The knots and fissures are stuccoed with special highly resistant products and a protective varnish increases the water and stain resistance of the surfaces.

Calor, hospitalidad, sentido del tiempo; la madera sabe ser primordial embajadora de la verdad y, al mismo tiempo, de un lujo refinado y táctil. Realizada a partir de madera de roble cepillada a mano, la madera Wildwood es trabajada artesanalmente resaltando sus imperfecciones naturales. Los nudos y las hendiduras son enmasilladas con productos especiales de alta resistencia y un barnizado protector reduce la permeabilidad de la superficie a los líquidos y las manchas.

Chaleur, hospitalité, sens du temps, le bois sait être le principal ambassadeur de la vérité et, parallèlement, d'un luxe raffiné et tactile. Fabriqué à partir de bois de chêne raboté à la main, Wildwood est un bois travaillé artisanalement: ses imperfections naturelles sont donc exaltées. Les nœuds et les fissures sont stuqués avec des produits spéciaux à haute résistance et la perméabilité de sa surface aux liquides et aux taches est limitée par un vernis protecteur.

Wärme, Gastfreundlichkeit, Zeitgefühl. Holz kann wirklich als der Ur-Botschafter der Wahrheit angesehen und zugleich als ausgearbeiteter und tastbarer Luxus eingesetzt werden. Es entsteht aus Eichenholz, das per Hand gehobelt wird. Das Wildwood wird einer traditionellen Bearbeitung per Hand unterworfen, die die natürliche Unvollkommenheit dieses Holzes rühmt und hervorhebt. Die Baumknoten und -ritzen sind mit speziellen Produkten für eine hohe Festigkeit gekittet. Ein Schutzlack versiegelt die Oberfläche, wodurch diese für Flüssigkeiten und Flecken undurchlässig werden.



CHIARO



NATURALE



TABACCO



SCURO

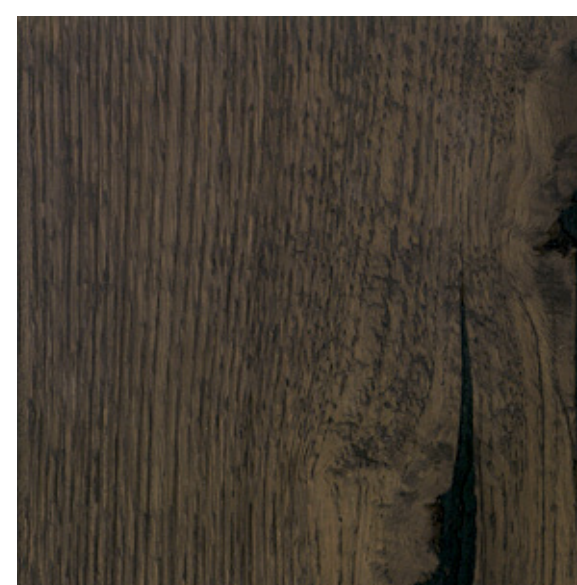

GRIGIO

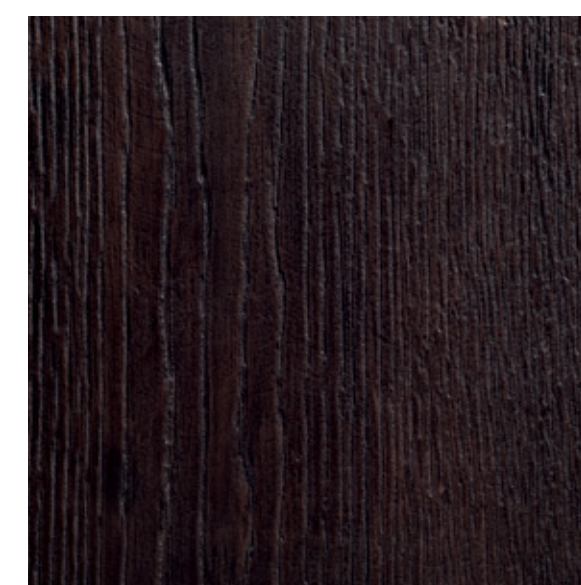

NERO