

# 36e8

Note tecniche// *Technical Notes*

67

**Contenitori NON riducibili in larghezza, altezza e profondità.**

**Per contenitori con due o più frontali di finiture diverse considerare il prezzo della finitura maggiore.**

**Ripiani interni in vetro inclusi. Contenitori con anta con ripiani removibili. Contenitori a giorno con ripiani fissi in fresata.**

**Contenitori affiancati o sovrapposti forniti con viti di giunzione. Se non richiedi specificarlo all'ordine.**

**Indicare sempre verso di apertura anta.**

**Se previsto da disegno verranno incluse le attaccaglie per la sospensione dei contenitori a muro. Senza disegno, richiederle se necessario.**

**Contenitori con profondità 51 cm da montare su pareti in calcestruzzo con tasselli chimici.**

*These storage units CANNOT be reduced in width, height or depth.*

*For storage units with two or more fronts in different finishes, take the higher finish price.*

*Internal glass shelves included. Storage units with door and removable shelves. Open storage units with fixed shelves.*

*Storage units side by side or stacked, supplied with connecting screws. If not required, please specify in the order.*

*Always indicate the door opening direction.*

*If indicated in the drawing, wall fittings will be included for hanging the storage units to the wall. If no drawing is provided, please ask for wall fittings when necessary.*

*Storage units, depth 51 cm, to be mounted on concrete walls with chemical anchors.*

## **STRUTTURA IN ROVERE GENTLE GENTLE OAK STRUCTURE**

I contenitori con struttura in Rovere Gentle hanno schienale e divisori interni laccati. È possibile specificarne il colore al momento dell'ordine. In assenza di indicazioni saranno forniti di colore spago.  
*Storage units with a Gentle oak structure have a lacquered back panel and internal partitions. Specify the colour when placing the order. Where not specified, they are supplied in colour spago.*

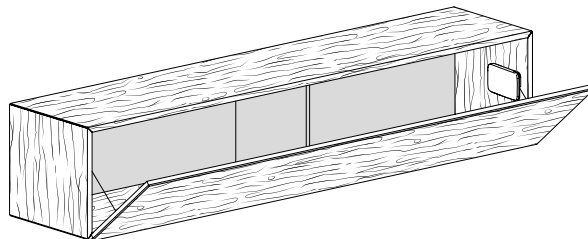

## **SIDE ROVERE GENTLE GENTLE OAK SIDE**

Per contenitori con struttura laccata e un solo lato in Rovere Gentle considerare il prezzo della struttura laccata.  
*For storage units with lacquered structure and one Gentle oak side, please consider the price of the lacquered structure.*

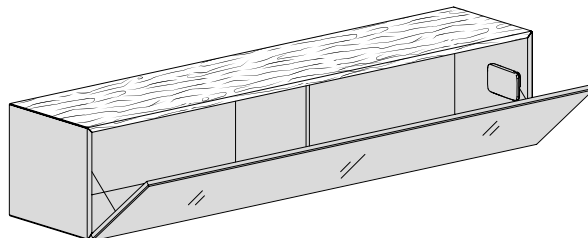

## **ANTE WILDWOOD WILDWOOD DOORS**

Non utilizzare pensili con ante Wildwood in ambienti cucina o bagno sopra fonti di umidità e calore.  
*Cabinets with doors in Wildwood are not suitable for kitchen and bathroom above moisture and heat sources*

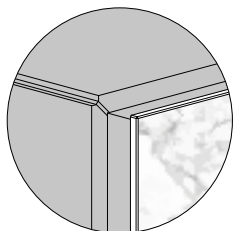
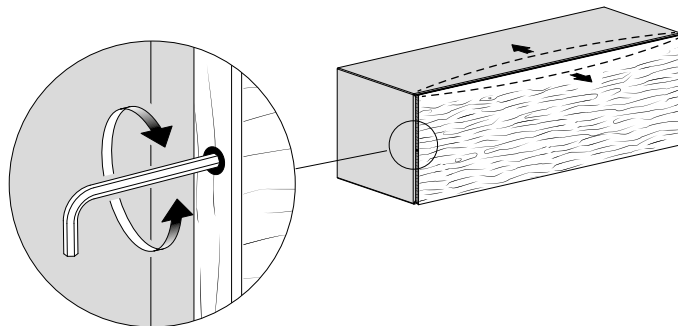

### **XGLASS CON STRUTTURA LACCATA XGLASS WITH LACQUERED STRUCTURE**

Per i frontali XGlass il pannello dell'anta che supporta il vetro prende il colore della struttura quando questa è laccata.  
*For the XGlass front doors, the panel of the door that supports the glass takes the colour of the structure when it is lacquered.*

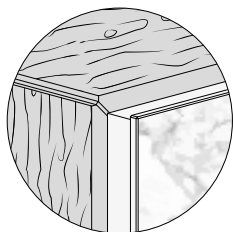

### **XGLASS CON STRUTTURA ROVERE GENTLE XGLASS WITH GENTLE OAK STRUCTURE**

Quando la struttura è Rovere Gentle il pannello dell'anta segue la finitura XGlass e prende il colore suggerito a listino. Per frontali a specchio il colore di default è spago se non diversamente specificato dal cliente. Si sconsiglia l'abbinamento della finitura XGlass legno con la struttura Rovere gentle.  
*When the structure is Gentle Oak, the door panel follows the XGlass finish and takes the suggested colour in the price list. For mirror fronts, the default color is spago unless otherwise specified by the customer. Combining the XGlass wood finish with the Gentle oak structure is not recommended.*

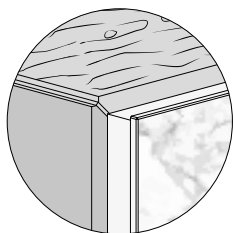

### **XGLASS CON STRUTTURA LACCATA E SIDE ROVERE GENTLE XGLASS WITH LACQUERED STRUCTURE AND GENTLE OAK SIDE**

Quando la struttura è laccata e un lato è Rovere Gentle il pannello dell'anta segue la finitura XGlass e prende il colore suggerito a listino (si consiglia di abbinare anche la struttura alla finitura XGlass). Per frontali a specchio il colore segue invece la struttura. Si sconsiglia l'abbinamento della finitura XGlass legno con un lato side in Rovere Gentle.  
*When the structure is lacquered and one side is Gentle Oak the door panel follows the XGlass finish and takes the suggested colour on the price list (we recommend also to match the structure to the XGlass finish). For mirror fronts, the colour follows the structure. Combining the XGlass wood finish with a Gentle oak side is not recommended.*

## FISSAGGIO SU CARTONGESSO FASTENING TO PLASTERBOARD

La sospensione degli elementi pensili è testata e verificata su pareti in mattone forato doppio UNI.

Le pareti in cartongesso presentano caratteristiche costruttive variabili in termini di spessore ed elementi strutturali, per cui non è possibile generalizzare un'indicazione di quali elementi sia opportuno installare.

È sempre necessaria una verifica preventiva da parte del venditore-progettista dell'idoneità della parete in funzione dell'elemento da installare.

Per i contenitori 36e8 è disponibile su richiesta una barra di sospensione intera fornita a misura del contenitore. Tasselli per cartongesso sono a cura del cliente. Per contenitori in vetro 36e8 Glass e pannelli a parete 36e8 Wall panels non è prevista la barra a misura.

Lago S.p.A. declina ogni responsabilità per danni causati a cose o persone che derivano da problemi di tenuta del muro o da una installazione non a regola d'arte.

*The wall unit hanging fixtures are checked and tested on UNI perforated double brick walls.*

*Plasterboard walls vary in thickness and in structural elements, therefore it is not possible to provide general indications on which units to install.*







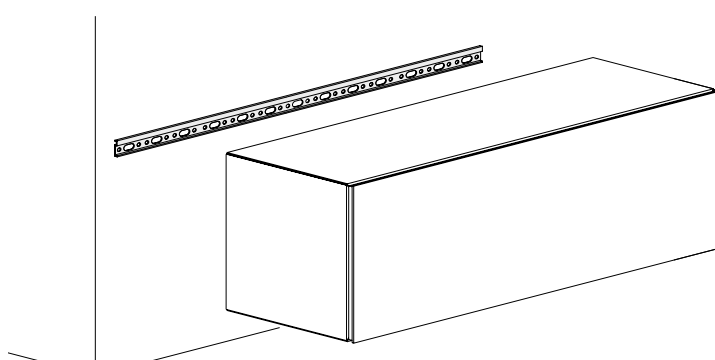

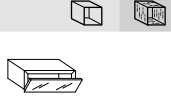
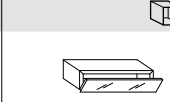

*The seller/designer must always check the suitability of the wall for the element to be installed in advance.*

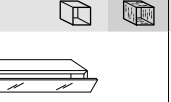
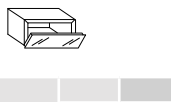
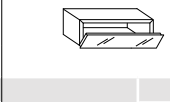
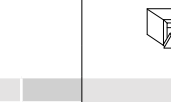
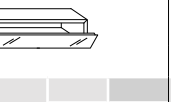
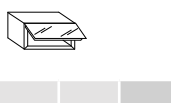
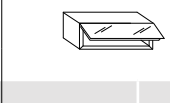
*For 36e8 storage units, a full suspension rod is available on request, supplied to fit the size of the storage unit. The plasterboard plugs are the customer's responsibility. For 36e8 Glass storage units and 36e8 Wall panels, there is no rod to size.*

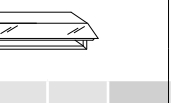
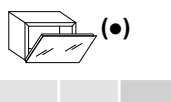
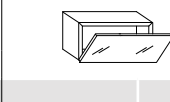
*Lago S.p.A. declines any liability for damage caused to people or property deriving from problems with the strength of the wall or installations that do not meet professional standards.*

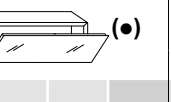
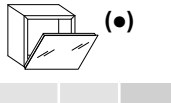
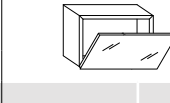
Descrizione//Description	Larghezza Width	Codice Code	
<b>Barra di sospensione intera per cartongesso</b> <i>Full suspension rod for plasterboard</i>   Non disponibile per profondità 51 cm. <i>Not available for depth 51 cm.</i>			
	36,8	TER7101	
	55,2	TER7102	
	73,6	TER7103	
	92	TER7104	
	110,4	TER7105	
	147,2	TER7106	
	184	TER7107	
	220,8	TER7108	

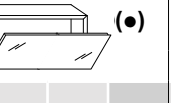
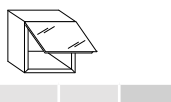
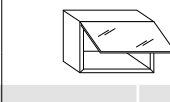
# P. 27 CONTENITORI//D. 27.0 STORAGE UNITS

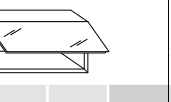
Altezza Height	Larghezza Width	36,8	55,2	73,6	92
Struttura laccata o Rovere Gentile//Lacquered or Gentle oak structure <b>13,8(••)</b> Ribalta//Bottom hung opening Frontale//Front Laccato//Lacquered Vetro lucido o specchio//Polished glass or mirror Vetro opaco//Matt glass XGlass lucido o opaco//Polished or matt XGlass Wildwood					
<b>18,4</b> Ribalta//Bottom hung opening Frontale//Front Laccato//Lacquered Vetro lucido o specchio//Polished glass or mirror Vetro opaco//Matt glass XGlass lucido o opaco//Polished or matt XGlass Wildwood					
<b>18,4</b> Vasistas//Top hung opening Frontale//Front Laccato//Lacquered Vetro lucido o specchio//Polished glass or mirror Vetro opaco//Matt glass XGlass lucido o opaco//Polished or matt XGlass Wildwood					
<b>27,6</b> Ribalta//Bottom hung opening Frontale//Front Laccato//Lacquered Vetro lucido o specchio//Polished glass or mirror Vetro opaco//Matt glass XGlass lucido o opaco//Polished or matt XGlass Wildwood					
<b>36,8</b> Ribalta//Bottom hung opening Frontale//Front Laccato//Lacquered Vetro lucido o specchio//Polished glass or mirror Vetro opaco//Matt glass XGlass lucido o opaco//Polished or matt XGlass Wildwood					
<b>36,8</b> Vasistas//Top hung opening Frontale//Front Laccato//Lacquered Vetro lucido o specchio//Polished glass or mirror Vetro opaco//Matt glass XGlass lucido o opaco//Polished or matt XGlass Wildwood					

(••) H 13,8 cm non sospendibile a parete.





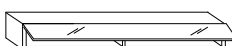

(••) H. 13,8 cm cannot be wall mounted.

(•) Il contenitore singolo a terra necessita di fissaggio a parete (no centrostanza). Di serie fornito con attaccaglie.

(•) The single floor-standing storage unit requires wall mounting (no stand-alone). Provided with wall fittings as standard.

110,4	147,2	184	220,8
 TEC211R	 TEC214R	 TEC218R	
 TEB211R	 TEB214R	 TEB218R	
 TEB211V	 TEB214V	 TEB218V	
 TED511R	 TED514R	 TED518R	 TED522R
 TEO511R	 TEO514R	 TEO518R	 TEO522R
 TEO511V	 TEO514V	 TEO518V	 TEO522V

# P. 27 CONTENITORI//D. 27.0 STORAGE UNITS

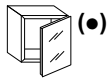
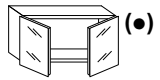
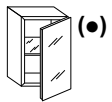
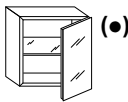
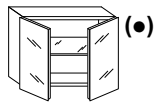
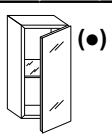
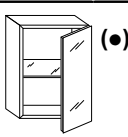
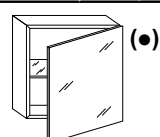
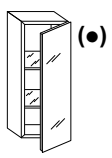
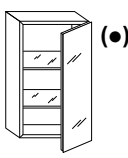
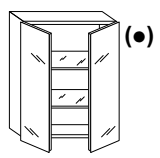
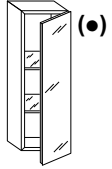
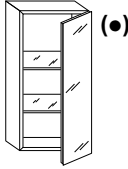
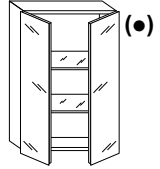
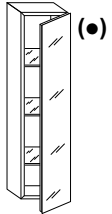
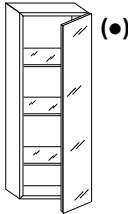
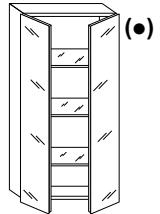











Altezza Height	Larghezza Width	36,8	55,2	73,6
Struttura laccata o Rovere Gentile//Lacquered or Gentle oak structure		 	 	 
<b>36,8</b> Anta battente Hinged door		 (●)		 (●)
Frontale//Front				
Laccato//Lacquered				
Vetro lucido o specchio//Polished glass or mirror				
Vetro opaco//Matt glass	TEV303			TEW303
XGlass lucido o opaco//Polished or matt XGlass				
Wildwood				
<b>55,2</b> Anta battente Hinged door		 (●)	 (●)	 (●)
Frontale//Front				
Laccato//Lacquered				
Vetro lucido o specchio//Polished glass or mirror				
Vetro opaco//Matt glass	TEV305	TV25055		TEW305
XGlass lucido o opaco//Polished or matt XGlass				
Wildwood				
<b>73,6</b> Anta battente Hinged door		 (●)	 (●)	 (●)
Frontale//Front				
Laccato//Lacquered				
Vetro lucido o specchio//Polished glass or mirror				
Vetro opaco//Matt glass	TEV307	TV25073	TEW307	TEW3075
XGlass lucido o opaco//Polished or matt XGlass				
Wildwood				
<b>92</b> Anta battente Hinged door		 (●)	 (●)	 (●)
Frontale//Front				
Laccato//Lacquered				
Vetro lucido o specchio//Polished glass or mirror				
Vetro opaco//Matt glass	TEV309	TV25092	TEW309	TEW3095
XGlass lucido o opaco//Polished or matt XGlass				
Wildwood				
<b>110,4</b> Anta battente Hinged door		 (●)	 (●)	 (●)
Frontale//Front				
Laccato//Lacquered				
Vetro lucido o specchio//Polished glass or mirror				
Vetro opaco//Matt glass	TEV311	TV25110	TEW311	TEW3115
XGlass lucido o opaco//Polished or matt XGlass				
Wildwood				
<b>147,2</b> Anta battente Hinged door		 (●)	 (●)	 (●)
Frontale//Front				
Laccato//Lacquered				
Vetro lucido o specchio//Polished glass or mirror				
Vetro opaco//Matt glass	TEV314	TV25147	TEW314	TEW3145
XGlass lucido o opaco//Polished or matt XGlass				
Wildwood				

(●) Il contenitore singolo a terra necessita di fissaggio a parete (no centrostanza). Di serie fornito con attaccaglie.  
 (●) The single floor-standing storage unit requires wall mounting (no stand-alone). Provided with wall fittings as standard.

# P. 27 CONTENITORI//D. 27 STORAGE UNITS

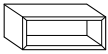
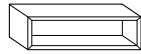
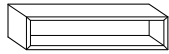
Altezza Height	Larghezza Width	36,8	55,2	73,6
Struttura laccata o Rovere Gentile//Lacquered or Gentle oak structure				
<b>184</b> Anta battente Hinged door				
	Frontale//Front	Push opzionale Optional push	Push opzionale Optional push	
Laccato//Lacquered				
Vetro lucido o specchio*//Polished glass or mirror*				
Vetro opaco//Matt glass	TEV318	TV25184	TEW318	TEW3185
XGlass lucido o opaco//Polished or matt XGlass				
Wildwood				
<b>220,8</b> Anta battente Hinged door				
	Frontale//Front	Push opzionale Optional push	Push opzionale Optional push	
Laccato//Lacquered				
Vetro lucido o specchio*//Polished glass or mirror*				
Vetro opaco//Matt glass	TEV322	TV25220	TEW322	
XGlass lucido o opaco//Polished or matt XGlass				
Wildwood				

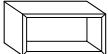
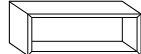
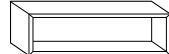

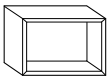
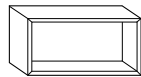
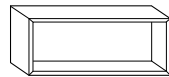











# P. 24,8 CONTENITORI A GIORNO//D. 24.8 OPEN STORAGE UNITS

Altezza Height	Larghezza Width	36,8	55,2	73,6	92
Struttura laccata o Rovere Gentile//Lacquered or Gentle oak structure		 	 	 	 
<b>18,4</b>					
Schiena laccata (tappi a vista)** Lacquered back (open caps)**		T2101	T2102	T2103	T2104
Maggiorazione per schiena vetro lucido o specchio Surcharge for polished glass or mirror back		SBN0001L	SBN0002L	SBN0003L	SBN0004L
Maggiorazione per schiena vetro opaco Surcharge for matt glass back		SBN0001O	SBN0002O	SBN0003O	SBN0004O
Maggiorazione per schiena XGlass lucido o opaco Surcharge for polished or matt XGlass back		SBN0001X	SBN0002X	SBN0003X	SBN0004X
<b>27,6</b>					
Schiena laccata (tappi a vista)** Lacquered back (open caps)**		T2151	T2152	T2153	T2154
Maggiorazione per schiena vetro lucido o specchio Surcharge for polished glass or mirror back		SBN0040L	SBN0041L	SBN0042L	SBN0043L
Maggiorazione per schiena vetro opaco Surcharge for matt glass back		SBN0040O	SBN0041O	SBN0042O	SBN0043O
Maggiorazione per schiena XGlass lucido o opaco Surcharge for polished or matt XGlass back		SBN0040X	SBN0041X	SBN0042X	SBN0043X
<b>36,8</b>					
Schiena laccata (tappi a vista)** Lacquered back (open caps)**		T2111	T2112	T2113	T2114
Maggiorazione per schiena vetro lucido o specchio Surcharge for polished glass or mirror back		SBN0009L	SBN0010L	SBN0011L	SBN0012L
Maggiorazione per schiena vetro opaco Surcharge for matt glass back		SBN0009O	SBN0010O	SBN0011O	SBN0012O
Maggiorazione per schiena XGlass lucido o opaco Surcharge for polished or matt XGlass back		SBN0009X	SBN0010X	SBN0011X	SBN0012X

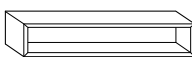

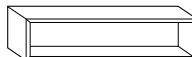



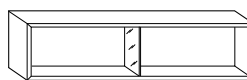
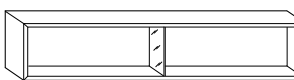
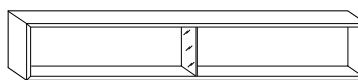

\*\* Vedi dettagli tecnici a pag. 78

\*\* See technical details on page 78



110,4		147,2		184		220,8	
							
							
T2105		T2107		T2108			
SBN0005L		SBN0006L		SBN0007L			
SBN0005O		SBN0006O		SBN0007O			
SBN0005X		SBN0006X		SBN0007X			
							
T2155		T2157		T2158		T2159	
SBN0044L		SBN0045L		SBN0046L		SBN0047L	
SBN0044O		SBN0045O		SBN0046O		SBN0047O	
SBN0044X		SBN0045X		SBN0046X		SBN0047X	
							
T2115		T2117		T2118		T2119	
SBN0013L		SBN0014L		SBN0015L		SBN0016L	
SBN0013O		SBN0014O		SBN0015O		SBN0016O	
SBN0013X		SBN0014X		SBN0015X		SBN0016X	

# P. 24,8 CONTENITORI A GIORNO//D. 24.8 OPEN STORAGE UNITS

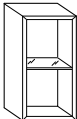
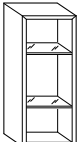
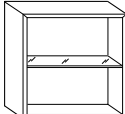
Larghezza Width	Altezza Height	36,8	55,2	73,6	92
Struttura laccata o Rovere Gentle//Lacquered or Gentle oak structure		 	 	 	 
<b>36,8</b> Ripiani non asportabili Non-removable shelves				 (●)	 (●)
Schiena laccata (tappi a vista)** Lacquered back (open caps)**				T2231	T2241
Maggiorazione per schiena vetro lucido o specchio Surcharge for polished glass or mirror back				SVT0307L	SVT0309L
Maggiorazione per schiena vetro opaco Surcharge for matt glass back				SVT0307O	SVT0309O
Maggiorazione per schiena XGlass lucido o opaco Surcharge for polished or matt XGlass back				SVT0307X	SVT0309X
<b>73,6</b> Ripiani non asportabili Non-removable shelves				 (●)	
Schiena laccata (tappi a vista)** Lacquered back (open caps)**				T2232	
Maggiorazione per schiena vetro lucido o specchio Surcharge for polished glass or mirror back				SVT0707L	
Maggiorazione per schiena vetro opaco Surcharge for matt glass back				SVT0707O	
Maggiorazione per schiena XGlass lucido o opaco Surcharge for polished or matt XGlass back				SVT0707X	







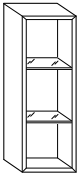
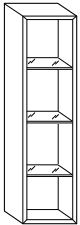
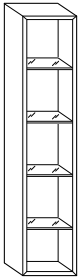
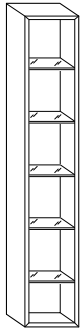
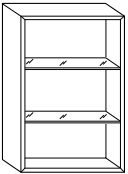
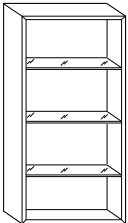
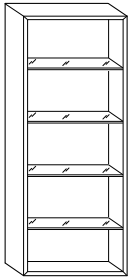
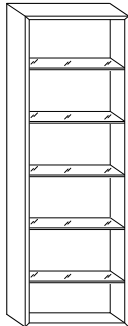







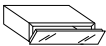

\*\* Vedi dettagli tecnici a pag. 78

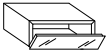
\*\* See technical details on page 78

(●) Il contenitore singolo a terra necessita di fissaggio a parete (no centrostanza). Di serie fornito con attaccaglie.  
(●) The single floor-standing storage unit requires wall mounting (no stand-alone). Provided with wall fittings as standard.

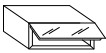
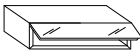
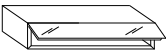

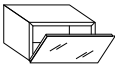
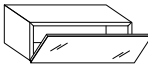
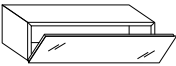
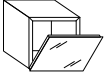
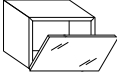

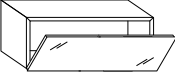
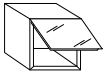
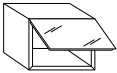
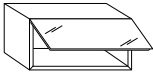
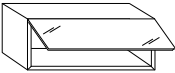





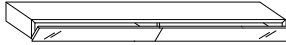

110,4		147,2		184		220,8	
							
T2251	T2271	T2281	T2291				
SVT0311L	SVT0314L	SVT0318L	SVT0322L				
SVT0311O	SVT0314O	SVT0318O	SVT0322O				
SVT0311X	SVT0314X	SVT0318X	SVT0322X				
							
T2252	T2272	T2282	T2292				
SVT0711L	SVT0714L	SVT0718L	SVT0722L				
SVT0711O	SVT0714O	SVT0718O	SVT0722O				
SVT0711X	SVT0714X	SVT0718X	SVT0722X				

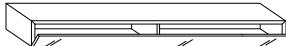
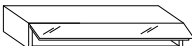
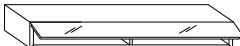
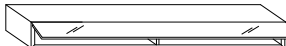
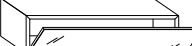
# P. 40,6 CONTENITORI//D. 40.6 STORAGE UNITS



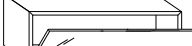

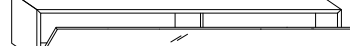
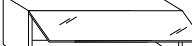
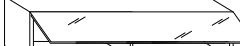

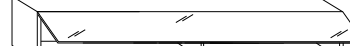















Altezza Height	Larghezza Width	36,8	55,2	73,6	92
Struttura laccata o Rovere Gentile//Lacquered or Gentle oak structure					
<b>13,8(••)</b> Ribalta//Bottom hung opening					
Frontale//Front					
Laccato//Lacquered					
Vetro lucido o specchio//Polished glass or mirror			TEC105R	TEC107R	TEC109R
Vetro opaco//Matt glass					
XGlass lucido o opaco//Polished or matt XGlass					
Wildwood					
<b>18,4</b> Ribalta//Bottom hung opening					
Frontale//Front					
Laccato//Lacquered					
Vetro lucido o specchio//Polished glass or mirror					
Vetro opaco//Matt glass		TEB103R	TEB105R	TEB107R	TEB109R
XGlass lucido o opaco//Polished or matt XGlass					
Wildwood					
<b>18,4</b> Vasistas//Top hung opening					
Frontale//Front					
Laccato//Lacquered					
Vetro lucido o specchio//Polished glass or mirror					
Vetro opaco//Matt glass		TEB103V	TEB105V	TEB107V	TEB109V
XGlass lucido o opaco//Polished or matt XGlass					
Wildwood					
<b>27,6</b> Ribalta//Bottom hung opening					
Frontale//Front					
Laccato//Lacquered					
Vetro lucido o specchio//Polished glass or mirror					
Vetro opaco//Matt glass		TED103R	TED105R	TED107R	TED109R
XGlass lucido o opaco//Polished or matt XGlass					
Wildwood					
<b>36,8</b> Ribalta//Bottom hung opening					
Frontale//Front					
Laccato//Lacquered					
Vetro lucido o specchio//Polished glass or mirror					
Vetro opaco//Matt glass		TEO103R	TEO105R	TEO107R	TEO109R
XGlass lucido o opaco//Polished or matt XGlass					
Wildwood					
<b>36,8</b> Vasistas//Top hung opening					
Frontale//Front					
Laccato//Lacquered					
Vetro lucido o specchio//Polished glass or mirror					
Vetro opaco//Matt glass		TEO103V	TEO105V	TEO107V	TEO109V
XGlass lucido o opaco//Polished or matt XGlass					
Wildwood					

(••) H 13,8 cm non sospendibile a parete.

(••) H. 13,8 cm cannot be wall mounted.

110,4	147,2	184	220,8
 TEC111R	 TEC114R	 TEC118R	
 TEB111R	 TEB114R	 TEB118R	
 TEB111V	 TEB114V	 TEB118V	
 TED511R	 TED114R	 TED118R	 TED122R
 TEO111R	 TEO114R	 TEO118R	 TEO122R
 TEO111V	 TEO114V	 TEO118V	 TEO122V

# P. 40,6 CONTENITORI//D. 40.6 STORAGE UNITS

Altezza Height	Larghezza Width	36,8	55,2	73,6
Struttura laccata o Rovere Gentle//Lacquered or Gentle oak structure		 	 	 
<b>13,8<sup>(**)</sup></b> 1 cassetto//1 drawer		 (●)	 (●)	 (●)
<b>Frontale//Front</b>				
Laccato//Lacquered				
Vetro lucido o specchio//Polished glass or mirror				
Vetro opaco//Matt glass	T4461		T4462	T4463
XGlass lucido o opaco//Polished or matt XGlass				
Wildwood				
<b>18,4</b> 1 cassetto//1 drawer		 (●)	 (●)	 (●)
<b>Frontale//Front</b>				
Laccato//Lacquered				
Vetro lucido o specchio//Polished glass or mirror				
Vetro opaco//Matt glass	T4401		T4402	T4403
XGlass lucido o opaco//Polished or matt XGlass				
Wildwood				
<b>27,6</b> Cestone//Deep drawer		 (●)	 (●)	 (●)
<b>Frontale//Front</b>				
Laccato//Lacquered				
Vetro lucido o specchio//Polished glass or mirror				
Vetro opaco//Matt glass	T4581		T4582	T4583
XGlass lucido o opaco//Polished or matt XGlass				
Wildwood				
<b>36,8</b> Cestone//Deep drawer		 (●)	 (●)	 (●)
<b>Frontale//Front</b>				
Laccato//Lacquered				
Vetro lucido o specchio//Polished glass or mirror				
Vetro opaco//Matt glass	T4511		T4512	T4513
XGlass lucido o opaco//Polished or matt XGlass				
Wildwood				
<b>36,8</b> 1 cassetto + vano a giorno 1 drawer + open compartment			 (●)	 (●)
<b>Frontale//Front</b>				
Laccato//Lacquered				
Vetro lucido o specchio//Polished glass or mirror				
Vetro opaco//Matt glass			T4612	T4613
XGlass lucido o opaco//Polished or matt XGlass				
Wildwood				
<b>36,8</b> 2 cassetti//2 drawers		 (●)	 (●)	 (●)
<b>Frontale//Front</b>				
Laccato//Lacquered				
Vetro lucido o specchio//Polished glass or mirror				
Vetro opaco//Matt glass	T4411		T4412	T4413
XGlass lucido o opaco//Polished or matt XGlass				
Wildwood				

92	110,4	147,2	184
 (●)	 (●)	 (●)	 (●)
T4464	T4465	T4467	T4468
 (●)	 (●)	 (***) (●)	 (***) (●)
T4404	T4405	T4407	T4408
 (●)	 (●)	 (***) (●)	 (***) (●)
T4584	T4585	T4587	T4588
 (●)	 (●)	 (***) (●)	 (***) (●)
T4514	T4515	T4517	T4518
 (●)	 (●)	 (●)	
T4614	T4615	T4617	
 (●)	 (●)	 (***) (●)	 (***) (●)
T4414	T4415	T4417	T4418

(●) Il contenitore singolo a terra necessita di fissaggio a parete (no centrostanza). Di serie fornito con attaccaglie.

(●) The single floor-standing storage unit requires wall mounting (no stand-alone). Provided with wall fittings as standard.













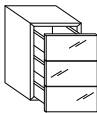
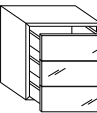
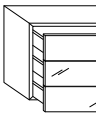
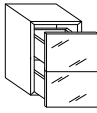
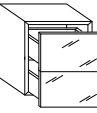
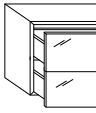
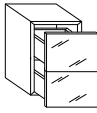
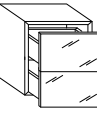
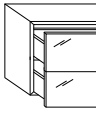
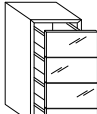
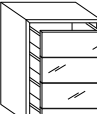

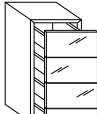
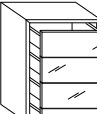







(●●) H 13,8 cm non sospendibile a parete.

(●●) H. 13,8 cm cannot be wall mounted.

(\*\*\*) Cassettiere con frontali unici di larghezza maggiore di 110,4 non sono utilizzabili a terra se il frontale non è accessibile dall'alto poiché l'apertura laterale non è efficace.

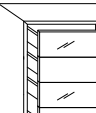

(\*\*\*) Chests of drawers with single fronts wider than 110,4 cannot be used as floor-standing units if the front is not accessible from above, as the side opening is not functional.

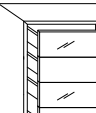
# P. 40,6 CONTENITORI//D. 40.6 STORAGE UNITS

Altezza Height	Larghezza Width	36,8	55,2	73,6
Struttura laccata o Rovere Gentle//Lacquered or Gentle oak structure				
<b>55,2</b> 3 cassetti//3 drawers		 (•)	 (•)	 (•)
<b>Frontale//Front</b>				
Laccato//Lacquered				
Vetro lucido o specchio//Polished glass or mirror				
Vetro opaco//Matt glass	T4421		T4422	T4423
XGlass lucido o opaco//Polished or matt XGlass				
Wildwood				
<b>55,2</b> 2 cestoni//2 deep drawers				
<b>Frontale//Front</b>				
Laccato//Lacquered				
Vetro lucido o specchio//Polished glass or mirror				
Vetro opaco//Matt glass	T4521		T4522	T4523
XGlass lucido o opaco//Polished or matt XGlass				
Wildwood				
<b>73,6</b> 4 cassetti//4 drawers		 (•)	 (•)	 (•)
<b>Frontale//Front</b>				
Laccato//Lacquered				
Vetro lucido o specchio//Polished glass or mirror				
Vetro opaco//Matt glass	T4431		T4432	T4433
XGlass lucido o opaco//Polished or matt XGlass				
Wildwood				
<b>92</b> 2 cassetti H 18,4 + 2 cestoni H 27,6//2 drawers H. 18,4 + 2 XL drawers H. 27,6		 (•)	 (•)	 (•)
<b>Frontale//Front</b>				
Laccato//Lacquered				
Vetro lucido o specchio//Polished glass or mirror				
Vetro opaco//Matt glass	T4391		T4392	T4393
XGlass lucido o opaco//Polished or matt XGlass				
Wildwood				
<b>110,4</b> 6 cassetti//6 drawers		 (•)	 (•)	 (•)
<b>Frontale//Front</b>				
Laccato//Lacquered				
Vetro lucido o specchio//Polished glass or mirror				
Vetro opaco//Matt glass	T4451		T4452	T4453
XGlass lucido o opaco//Polished or matt XGlass				
Wildwood				
<b>110,4</b> 3 cassetti H 18,4 + 2 cestoni H 27,6//3 drawers H. 18,4 + 2 XL drawers H. 27,6		 (•)	 (•)	 (•)
<b>Frontale//Front</b>				
Laccato//Lacquered				
Vetro lucido o specchio//Polished glass or mirror				
Vetro opaco//Matt glass	T4351		T4352	T4353
XGlass lucido o opaco//Polished or matt XGlass				
Wildwood				

(•) Il contenitore singolo a terra necessita di fissaggio a parete (no centrostanza). Di serie fornito con attaccaglie.  
 (•) The single floor-standing storage unit requires wall mounting (no stand-alone). Provided with wall fittings as standard.

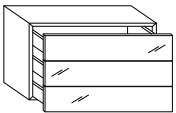
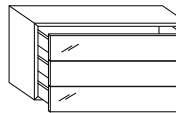
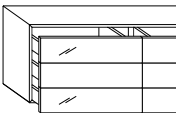
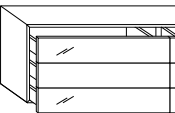
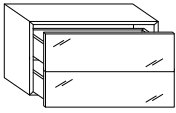
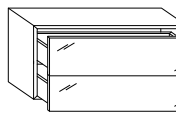
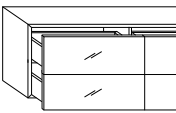
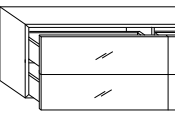
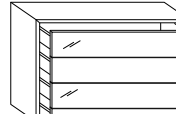
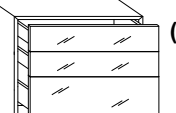
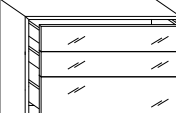
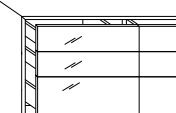
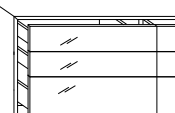
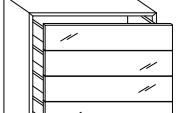

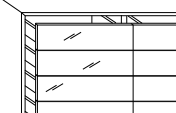
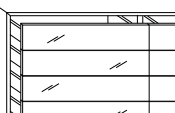
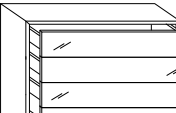
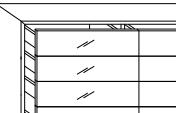
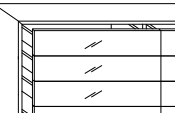
92	110,4	147,2	184
 (●)	 (●)	 (●)	 (●)
T4424	T4425	T4427	T4428
			 (●)
T4524	T4525	T4527	T4528
 (●)	 (●)	 (**) (●)	 (**) (●)
T4434	T4435	T4437	T4438
 (●)	 (●)	 (**) (●)	 (**) (●)
T4394	T4395	T4397	T4398
 (●)	 (●)	 (**) (●)	 (**) (●)
T4454	T4455	T4457	T4458
 (●)	 (●)	 (**) (●)	 (**) (●)
T4354	T4355	T4357	T4358

(\*\*) Utilizzabile solo in appoggio a terra.  
 (\*\*) Floor-standing only.

# P. 40,6 CONTENITORI//D. 40.6 STORAGE UNITS









Altezza Height	Larghezza Width	36,8	55,2	73,6
<b>36,8</b> Anta battente Hinged door  <b>Frontale//Front</b> Laccato//Lacquered Vetro lucido o specchio//Polished glass or mirror Vetro opaco//Matt glass XGlass lucido o opaco//Polished or matt XGlass Wildwood				
		TEV103		TEW1035
<b>55,2</b> Anta battente Hinged door  <b>Frontale//Front</b> Laccato//Lacquered Vetro lucido o specchio//Polished glass or mirror Vetro opaco//Matt glass XGlass lucido o opaco//Polished or matt XGlass Wildwood				
		TEV105	TV45055	TEW1055
			-	
<b>73,6</b> Anta battente Hinged door  <b>Frontale//Front</b> Laccato//Lacquered Vetro lucido o specchio//Polished glass or mirror Vetro opaco//Matt glass XGlass lucido o opaco//Polished or matt XGlass Wildwood				
		TEV107	TV45073	TEW107
			-	-
<b>92</b> Anta battente Hinged door  <b>Frontale//Front</b> Laccato//Lacquered Vetro lucido o specchio//Polished glass or mirror Vetro opaco//Matt glass XGlass lucido o opaco//Polished or matt XGlass Wildwood				
		TEV109	TV45092	TEW109
			-	-
<b>110,4</b> Anta battente Hinged door  <b>Frontale//Front</b> Laccato//Lacquered Vetro lucido o specchio//Polished glass or mirror Vetro opaco//Matt glass XGlass lucido o opaco//Polished or matt XGlass Wildwood				
		TEV111	TV45110	TEW111
			-	-
<b>147,2</b> Anta battente Hinged door  <b>Frontale//Front</b> Laccato//Lacquered Vetro lucido o specchio//Polished glass or mirror Vetro opaco//Matt glass XGlass lucido o opaco//Polished or matt XGlass Wildwood				
		TEV114	TV45147	TEW114
			-	-



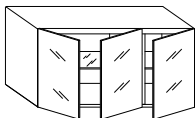
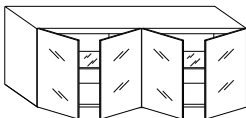

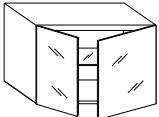
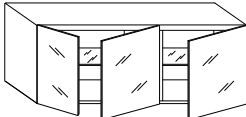
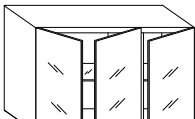
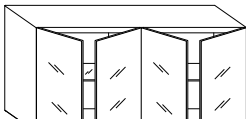
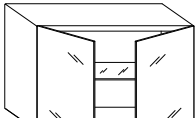
(●) Il contenitore singolo a terra necessita di fissaggio a parete (no centrostanza). Di serie fornito con attaccaglie.  
 (●) The single floor-standing storage unit requires wall mounting (no stand-alone). Provided with wall fittings as standard.

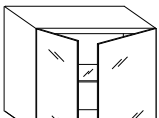
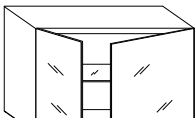
# P. 40,6 CONTENITORI//D. 40.6 STORAGE UNITS



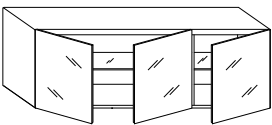

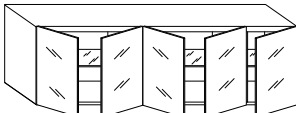

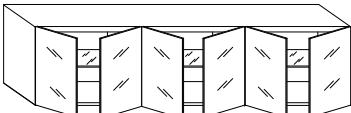
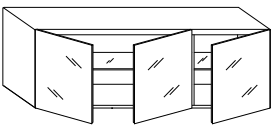
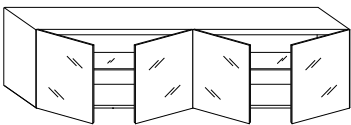
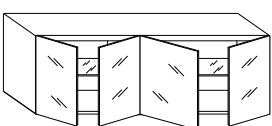
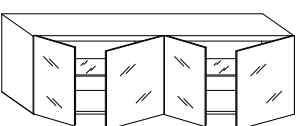
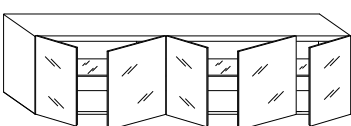
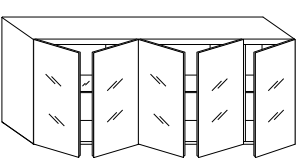
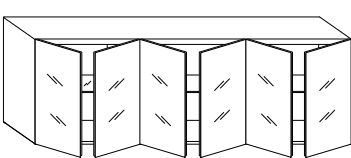
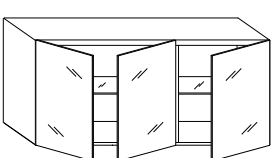
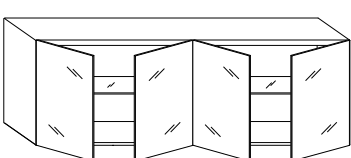
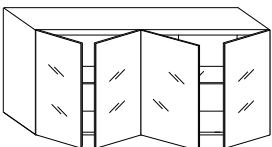
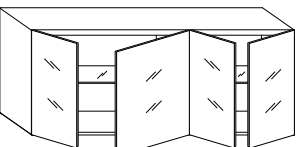
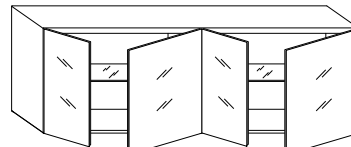





Altezza Height	Larghezza Width	36,8	55,2	73,6
<b>184</b> Anta battente Hinged door	Struttura laccata o Rovere Gentle// Lacquered or Gentle oak structure			
	Frontale//Front	Push opzionale Optional push	Push opzionale Optional push	
	Laccato//Lacquered			
	Vetro lucido o specchio//Polished glass or mirror*	TEV118	TV45184	TEW118
	Vetro opaco//Matt glass			TEW1185
XGlass lucido o opaco//Polished or matt XGlass				
Wildwood		-	-	
<b>220,8</b> Anta battente Hinged door	Struttura laccata o Rovere Gentle// Lacquered or Gentle oak structure			
	Frontale//Front	Push opzionale Optional push	Push opzionale Optional push	
	Laccato//Lacquered			
	Vetro lucido o specchio//Polished glass or mirror*	TEV122	TV45220	TEW122
	Vetro opaco//Matt glass			
XGlass lucido o opaco//Polished or matt XGlass				
Wildwood		-	-	



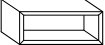
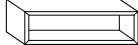
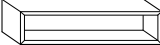

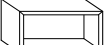
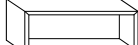
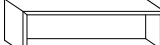

# P. 40,6 CONTENITORI//D. 40.6 STORAGE UNITS

Altezza Height	Larghezza Width	92	110,4	147,2
<b>55,2</b> <b>Anta battente</b> <b>Hinged door</b>				
<b>Struttura laccata o Rovere Gentle//</b> <b>Lacquered or Gentle oak structure</b>				
<b>Frontale//Front</b> Laccato//Lacquered Vetro lucido o specchio*//Polished glass or mirror* Vetro opaco//Matt glass XGlass lucido o opaco//Polished or matt XGlass Wildwood			TDE400	TEE560
<b>55,2</b> <b>Anta battente</b> <b>Hinged door</b>				
<b>Frontale//Front</b> Laccato//Lacquered Vetro lucido o specchio*//Polished glass or mirror* Vetro opaco//Matt glass XGlass lucido o opaco//Polished or matt XGlass Wildwood			TDE410	
<b>55,2</b> <b>Anta battente</b> <b>Hinged door</b>				
<b>Frontale//Front</b> Laccato//Lacquered Vetro lucido o specchio*//Polished glass or mirror* Vetro opaco//Matt glass XGlass lucido o opaco//Polished or matt XGlass Wildwood		TDE100		TDE420
<b>73,6</b> <b>Anta battente</b> <b>Hinged door</b>				
<b>Frontale//Front</b> Laccato//Lacquered Vetro lucido o specchio*//Polished glass or mirror* Vetro opaco//Matt glass XGlass lucido o opaco//Polished or matt XGlass Wildwood			TDE230	TDE550
<b>73,6</b> <b>Anta battente</b> <b>Hinged door</b>				
<b>Frontale//Front</b> Laccato//Lacquered Vetro lucido o specchio*//Polished glass or mirror* Vetro opaco//Matt glass XGlass lucido o opaco//Polished or matt XGlass Wildwood			TDE220	TDE311
<b>73,6</b> <b>Anta battente</b> <b>Hinged door</b>				
<b>Frontale//Front</b> Laccato//Lacquered Vetro lucido o specchio*//Polished glass or mirror* Vetro opaco//Matt glass XGlass lucido o opaco//Polished or matt XGlass Wildwood		TDE110	TDE212	TDE540

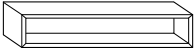
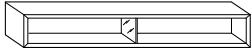
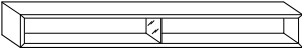
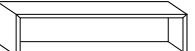
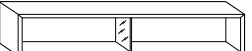



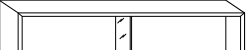

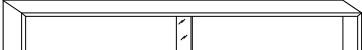

165,6	184	220,8
  TDE430	  TDE450	  TDE500
 TDE440		 TDE510
 TDE440	 TDE460	 TDE515
	 TDE535	 TDE521
 TDE320		 TDE522
 TDE330	 TDE530	 TDE520

# P. 38,4 CONTENITORI A GIORNO//D. 38.4 OPEN STORAGE UNITS

Altezza Height	Larghezza Width		36,8	55,2	73,6	92
Struttura laccata o Rovere Gentle//Lacquered or Gentle oak structure						
<b>18,4</b>						
Schiena laccata (tappi a vista)** Lacquered back (open caps)**	T4101		T4102		T4103	T4104
Maggiorazione per schiena vetro lucido o specchio Surcharge for polished glass or mirror back	SBN0001L		SBN0002L		SBN0003L	SBN0004L
Maggiorazione per schiena vetro opaco Surcharge for matt glass back	SBN0001O		SBN0002O		SBN0003O	SBN0004O
Maggiorazione per schiena XGlass lucido o opaco Surcharge for polished or matt XGlass back	SBN0001X		SBN0002X		SBN0003X	SBN0004X
<b>27,6</b>						
Schiena laccata (tappi a vista)** Lacquered back (open caps)**	T4151		T4152		T4153	T4154
Maggiorazione per schiena vetro lucido o specchio Surcharge for polished glass or mirror back	SBN0040L		SBN0041L		SBN0042L	SBN0043L
Maggiorazione per schiena vetro opaco Surcharge for matt glass back	SBN0040O		SBN0041O		SBN0042O	SBN0043O
Maggiorazione per schiena XGlass lucido o opaco Surcharge for polished or matt XGlass back	SBN0040X		SBN0041X		SBN0042X	SBN0043X
<b>36,8</b>						
Schiena laccata (tappi a vista)** Lacquered back (open caps)**	T4111		T4112		T4113	T4114
Maggiorazione per schiena vetro lucido o specchio Surcharge for polished glass or mirror back	SBN0009L		SBN0010L		SBN0011L	SBN0012L
Maggiorazione per schiena vetro opaco Surcharge for matt glass back	SBN0009O		SBN0010O		SBN0011O	SBN0012O
Maggiorazione per schiena XGlass lucido o opaco Surcharge for polished or matt XGlass back	SBN0009X		SBN0010X		SBN0011X	SBN0012X

110,4			147,2			184			220,8		
											
T4105			T4107			T4108					
SBN0005L			SBN0006L			SBN0007L					
SBN0005O			SBN0006O			SBN0007O					
SBN0005X			SBN0006X			SBN0007X					
											
T4155			T4157			T4158			T4159		
SBN0044L			SBN0045L			SBN0046L			SBN0047L		
SBN0044O			SBN0045O			SBN0046O			SBN0047O		
SBN0044X			SBN0045X			SBN0046X			SBN0047X		
											
T4115			T4117			T4118			T4119		
SBN0013L			SBN0014L			SBN0015L			SBN0016L		
SBN0013O			SBN0014O			SBN0015O			SBN0016O		
SBN0013X			SBN0014X			SBN0015X			SBN0016X		

# P. 38,4 CONTENITORI A GIORNO//D. 38.4 OPEN STORAGE UNITS

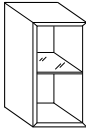
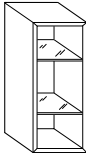
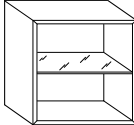
Larghezza Width	Altezza Height	36,8	55,2	73,6	92
Struttura laccata o Rovere Gentle//Lacquered or Gentle oak structure		 	 	 	 
<b>36,8</b> Ripiani non asportabili Non-removable shelves					
Schiena laccata (tappi a vista)** Lacquered back (open caps)**				T4231	T4241
Maggiorazione per schiena vetro lucido o specchio Surcharge for polished glass or mirror back				SVT0307L	SVT0309L
Maggiorazione per schiena vetro opaco Surcharge for matt glass back				SVT0307O	SVT0309O
Maggiorazione per schiena XGlass lucido o opaco Surcharge for polished or matt XGlass back				SVT0307X	SVT0309X
<b>73,6</b> Ripiani non asportabili Non-removable shelves					
Schiena laccata (tappi a vista)** Lacquered back (open caps)**				T4232	
Maggiorazione per schiena vetro lucido o specchio Surcharge for polished glass or mirror back				SVT0707L	
Maggiorazione per schiena vetro opaco Surcharge for matt glass back				SVT0707O	
Maggiorazione per schiena XGlass lucido o opaco Surcharge for polished or matt XGlass back				SVT0707X	

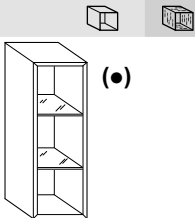
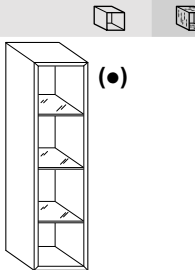
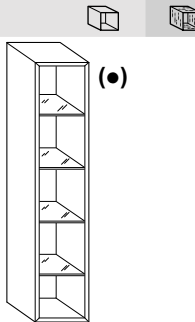
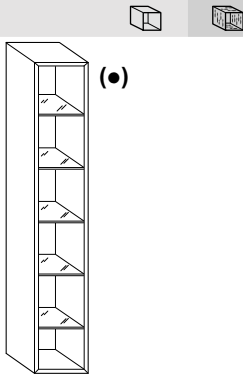
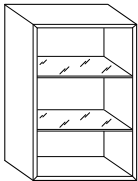
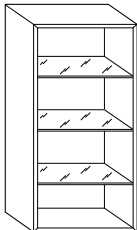
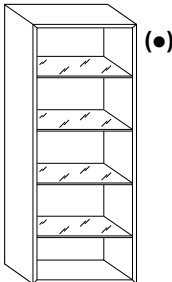
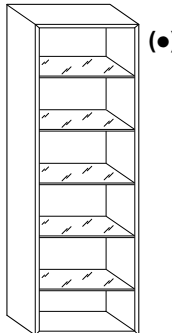

110,4	147,2	184	220,8
			
T4251	T4271	T4281	T4291
SVT0311L	SVT0314L	SVT0318L	SVT0322L
SVT0311O	SVT0314O	SVT0318O	SVT0322O
SVT0311X	SVT0314X	SVT0318X	SVT0322X
			
T4252	T4272	T4282	T4292
SVT0711L	SVT0714L	SVT0718L	SVT0722L
SVT0711O	SVT0714O	SVT0718O	SVT0722O
SVT0711X	SVT0714X	SVT0718X	SVT0722X

(●) Il contenitore singolo a terra necessita di fissaggio a parete (no centrostanza). Di serie fornito con attaccaglie.  
 (●) The single floor-standing storage unit requires wall mounting (no stand-alone). Provided with wall fittings as standard.

\*\* Vedi dettagli tecnici a pag. 78  
 \*\* See technical details on page 78

# P. 51 CONTENITORI//D. 51.0 STORAGE UNITS

Altezza Height	Larghezza Width	36,8	55,2	73,6	
Struttura laccata o Rovere Gentile//Lacquered or Gentle oak structure					
<b>13,8(••)</b> Ribalta//Bottom hung opening					
<b>Frontale//Front</b>					
Laccato//Lacquered					
Vetro lucido o specchio//Polished glass or mirror					
Vetro opaco//Matt glass					
XGlass lucido o opaco//Polished or matt XGlass					
Wildwood					
<b>18,4</b> Ribalta//Bottom hung opening					
<b>Frontale//Front</b>					
Laccato//Lacquered					
Vetro lucido o specchio//Polished glass or mirror					
Vetro opaco//Matt glass					
XGlass lucido o opaco//Polished or matt XGlass					
Wildwood					
<b>27,6</b> Ribalta//Bottom hung opening					
<b>Frontale//Front</b>					
Laccato//Lacquered					
Vetro lucido o specchio//Polished glass or mirror					
Vetro opaco//Matt glass					
XGlass lucido o opaco//Polished or matt XGlass					
Wildwood					
<b>36,8</b> Ribalta//Bottom hung opening					
<b>Frontale//Front</b>					
Laccato//Lacquered					
Vetro lucido o specchio//Polished glass or mirror					
Vetro opaco//Matt glass					
XGlass lucido o opaco//Polished or matt XGlass					
Wildwood					
<b>55,2</b> Anta battente//Hinged door					
<b>Frontale//Front</b>					
Laccato//Lacquered					
Vetro lucido o specchio//Polished glass or mirror					
Vetro opaco//Matt glass					
XGlass lucido o opaco//Polished or matt XGlass					
Wildwood					
<b>73,6</b> Anta//Door					
<b>Frontale//Front</b>					
Laccato//Lacquered					
Vetro lucido o specchio//Polished glass or mirror					
Vetro opaco//Matt glass					
XGlass lucido o opaco//Polished or matt XGlass					
Wildwood					

(••) H 13,8 cm non sospendibile a parete.

(••) H. 13,8 cm cannot be wall mounted.

92

110,4

147,2

184

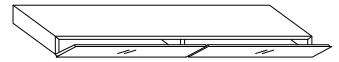
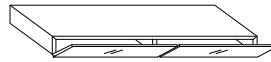

TEC609R

TEC611R

TEC614R

TEC618R

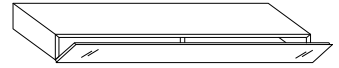
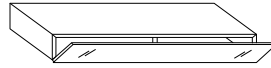
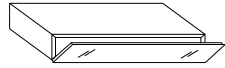
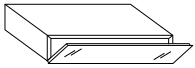

TEB609R

TEB611R

TEB614R

TEB618R

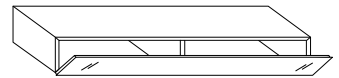
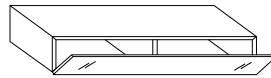
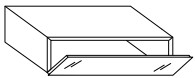

TED609R

TED611R

TED614R

TED618R

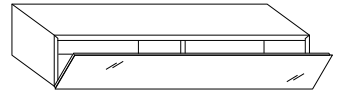
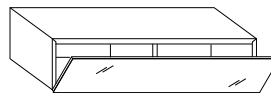
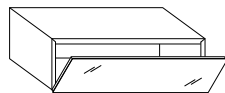
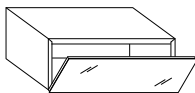



TEO609R

TEO611R

TEO614R



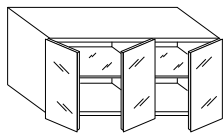
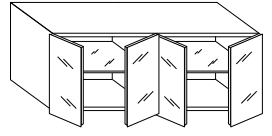
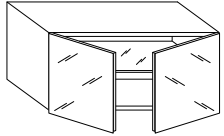
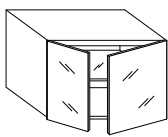
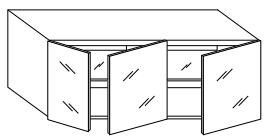
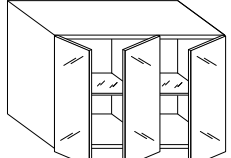
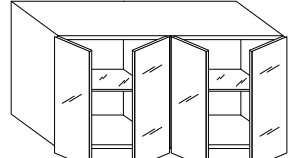
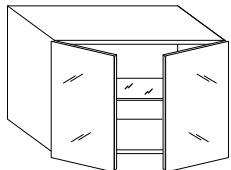
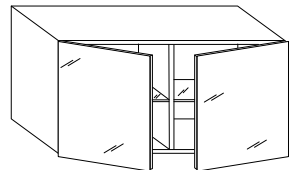
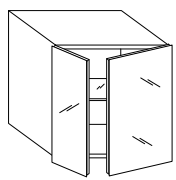
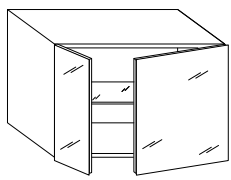
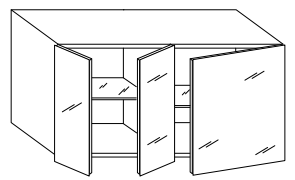

TEO618R

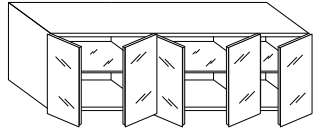
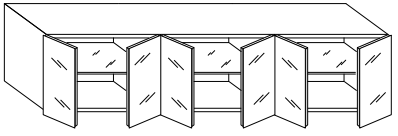
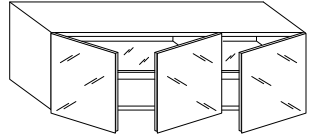
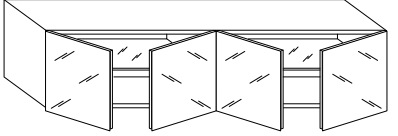
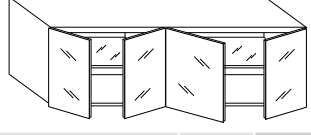
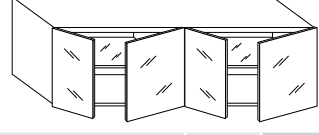
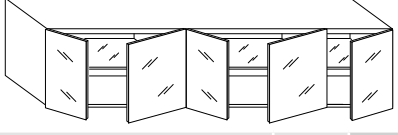
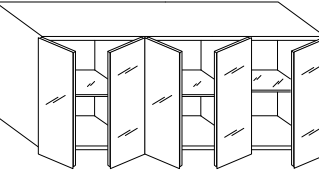
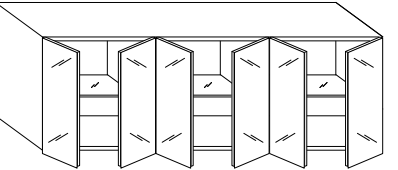
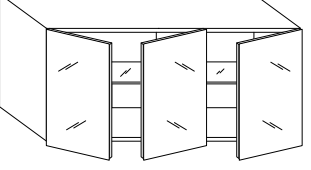
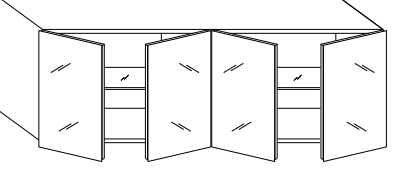
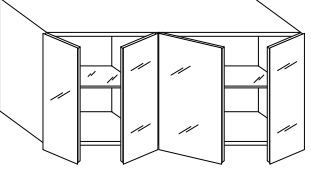
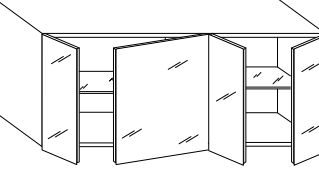
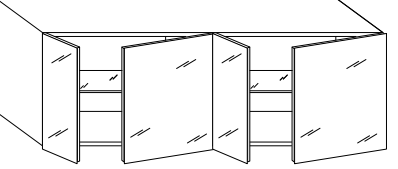
# P. 51 CONTENITORI//D. 51.0 STORAGE UNITS

Altezza Height	Larghezza Width	92	110,4	147,2
<b>55,2</b> <b>Anta battente</b> <b>Hinged door</b>  <b>Frontale//Front</b> Laccato//Lacquered Vetro lucido o specchio*//Polished glass or mirror* Vetro opaco//Matt glass XGlass lucido o opaco//Polished or matt XGlass Wildwood				
				
			TCW050	TCW060
<b>55,2</b> <b>Anta battente</b> <b>Hinged door</b>  <b>Frontale//Front</b> Laccato//Lacquered Vetro lucido o specchio*//Polished glass or mirror* Vetro opaco//Matt glass XGlass lucido o opaco//Polished or matt XGlass Wildwood				
			TCV050	
<b>55,2</b> <b>Anta battente</b> <b>Hinged door</b>  <b>Frontale//Front</b> Laccato//Lacquered Vetro lucido o specchio*//Polished glass or mirror* Vetro opaco//Matt glass XGlass lucido o opaco//Polished or matt XGlass Wildwood				
		TCA040		TCA060
<b>73,6</b> <b>Anta battente</b> <b>Hinged door</b>  <b>Frontale//Front</b> Laccato//Lacquered Vetro lucido o specchio*//Polished glass or mirror* Vetro opaco//Matt glass XGlass lucido o opaco//Polished or matt XGlass Wildwood				
			TCW051	TCW061
<b>73,6</b> <b>Anta battente</b> <b>Hinged door</b>  <b>Frontale//Front</b> Laccato//Lacquered Vetro lucido o specchio*//Polished glass or mirror* Vetro opaco//Matt glass XGlass lucido o opaco//Polished or matt XGlass Wildwood				
			TCV051	TCV061
<b>73,6</b> <b>Anta battente</b> <b>Hinged door</b>  <b>Frontale//Front</b> Laccato//Lacquered Vetro lucido o specchio*//Polished glass or mirror* Vetro opaco//Matt glass XGlass lucido o opaco//Polished or matt XGlass Wildwood				
		TCA041	TCA051	TCA061

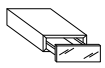
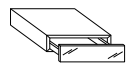
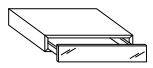
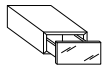
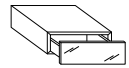
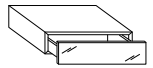

165,6	184	220,8
  TCW080	 TCW090	 TCV070
 TCV090	 TCA070	 TCA080
 TCA090	 TCW080	 TCW090
 TCV071	 TCV091	 TCA071
 TCA081	 TCA091	

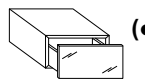
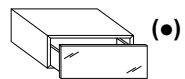
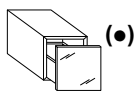
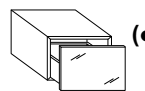
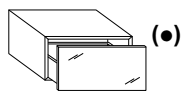
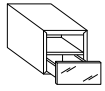
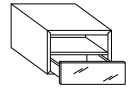
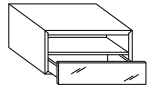
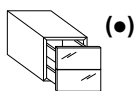
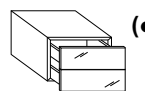
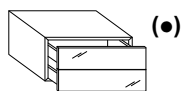
# P. 51 CONTENITORI//D. 51.0 STORAGE UNITS

Altezza Height	Larghezza Width	36,8	55,2	73,6
Struttura laccata o Rovere Gentile//Lacquered or Gentile oak structure				
<b>13,8(••)</b> 1 cassetto//1 drawer				
<b>Frontale//Front</b> Laccato//Lacquered Vetro lucido o specchio//Polished glass or mirror Vetro opaco//Matt glass XGlass lucido o opaco//Polished or matt XGlass Wildwood		T6461	T6462	T6463
<b>18,4</b> 1 cassetto//1 drawer				
<b>Frontale//Front</b> Laccato//Lacquered Vetro lucido o specchio//Polished glass or mirror Vetro opaco//Matt glass XGlass lucido o opaco//Polished or matt XGlass Wildwood		T6401	T6402	T6403
<b>27,6</b> Cestone//Deep drawer				
<b>Frontale//Front</b> Laccato//Lacquered Vetro lucido o specchio//Polished glass or mirror Vetro opaco//Matt glass XGlass lucido o opaco//Polished or matt XGlass Wildwood		T6581	T6582	T6583
<b>36,8</b> Cestone//Deep drawer				
<b>Frontale//Front</b> Laccato//Lacquered Vetro lucido o specchio//Polished glass or mirror Vetro opaco//Matt glass XGlass lucido o opaco//Polished or matt XGlass Wildwood		T6511	T6512	T6513
<b>36,8</b> 1 cassetto + vano a giorno 1 drawer + open compartment				
<b>Frontale//Front</b> Laccato//Lacquered Vetro lucido o specchio//Polished glass or mirror Vetro opaco//Matt glass XGlass lucido o opaco//Polished or matt XGlass Wildwood		T6611	T6612	T6613
<b>36,8</b> 2 cassetti//2 drawers				
<b>Frontale//Front</b> Laccato//Lacquered Vetro lucido o specchio//Polished glass or mirror Vetro opaco//Matt glass XGlass lucido o opaco//Polished or matt XGlass Wildwood		T6411	T6412	T6413

(••) H 13,8 cm non sospendibile a parete.

(••) H. 13,8 cm cannot be wall mounted.

92	110,4	147,2	184
 T6464	 T6465	 T6467	 T6468
 T6404	 T6405	 T6407	 T6408
 T6584	 T6585	 T6587	 T6588
 T6514	 T6515	 T6517	 T6518
 T6614	 T6615	 T6617	 T6618
 T6414	 T6415	 T6417	 T6418

(●) Il contenitore singolo a terra necessita di fissaggio a parete (no centrostanza). Di serie fornito con attaccaglie.

(●) The single floor-standing storage unit requires wall mounting (no stand-alone). Provided with wall fittings as standard.

(\*\*) Utilizzabile solo in appoggio a terra.

(\*\*) Floor-standing only.

(\*\*\*) Cassettiere con frontali unici di larghezza maggiore di 110,4 non sono utilizzabili a terra se il frontale non è accessibile dall'alto poiché l'apertura laterale non è efficace.

(\*\*\*) Chests of drawers with single fronts wider than 110,4 cannot be used as floor-standing units if the front is not accessible from above, as the side opening is not functional.

# P. 51 CONTENITORI//D. 51.0 STORAGE UNITS

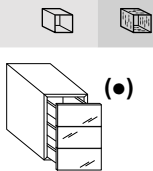
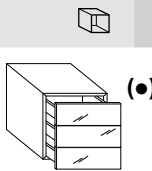
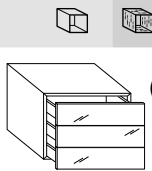
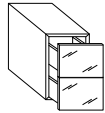
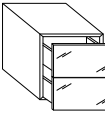
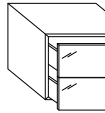
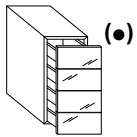
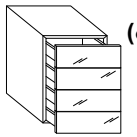
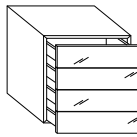
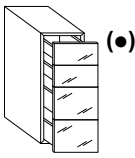
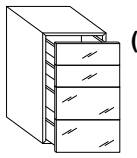
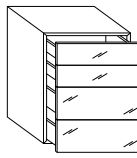
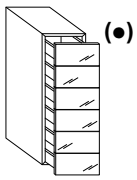
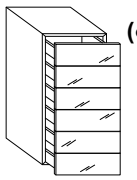
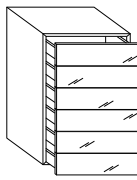
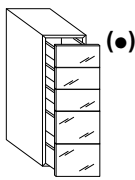
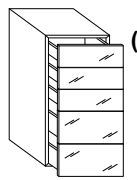
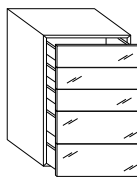
Altezza Height	Larghezza Width	36,8	55,2	73,6
Struttura laccata o Rovere Gentle//Lacquered or Gentle oak structure				
<b>55,2</b> 3 cassetti//3 drawers				
<b>Frontale//Front</b>				
Laccato//Lacquered				
Vetro lucido o specchio//Polished glass or mirror				
Vetro opaco//Matt glass	T6421	T6422	T6423	
XGlass lucido o opaco//Polished or matt XGlass				
Wildwood				
<b>55,2</b> 2 cestoni//2 deep drawers				
<b>Frontale//Front</b>				
Laccato//Lacquered				
Vetro lucido o specchio//Polished glass or mirror				
Vetro opaco//Matt glass	T6521	T6522	T6523	
XGlass lucido o opaco//Polished or matt XGlass				
Wildwood				
<b>73,6</b> 4 cassetti//4 drawers				
<b>Frontale//Front</b>				
Laccato//Lacquered				
Vetro lucido o specchio//Polished glass or mirror				
Vetro opaco//Matt glass	T6431	T6432	T6433	
XGlass lucido o opaco//Polished or matt XGlass				
Wildwood				
<b>92</b> 2 cassetti H 18,4 + 2 cestoni H 27,6 2 drawers H. 18,4 + 2 XL drawers H. 27,6				
<b>Frontale//Front</b>				
Laccato//Lacquered				
Vetro lucido o specchio//Polished glass or mirror				
Vetro opaco//Matt glass	T6391	T6392	T6393	
XGlass lucido o opaco//Polished or matt XGlass				
Wildwood				
<b>110,4</b> 6 cassetti//6 drawers				
<b>Frontale//Front</b>				
Laccato//Lacquered				
Vetro lucido o specchio//Polished glass or mirror				
Vetro opaco//Matt glass	T6451	T6452	T6453	
XGlass lucido o opaco//Polished or matt XGlass				
Wildwood				
<b>110,4</b> 3 cassetti H 18,4 + 2 cestoni H 27,6 3 drawers H. 18,4 + 2 XL drawers H. 27,6				
<b>Frontale//Front</b>				
Laccato//Lacquered				
Vetro lucido o specchio//Polished glass or mirror				
Vetro opaco//Matt glass	T6351	T6352	T6353	
XGlass lucido o opaco//Polished or matt XGlass				
Wildwood				

(●) Il contenitore singolo a terra necessita di fissaggio a parete (no centrostanza). Di serie fornito con attaccaglie.  
 (●) The single floor-standing storage unit requires wall mounting (no stand-alone). Provided with wall fittings as standard.

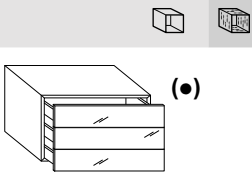
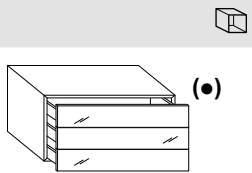
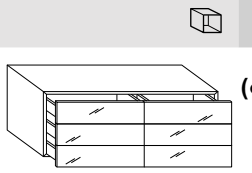
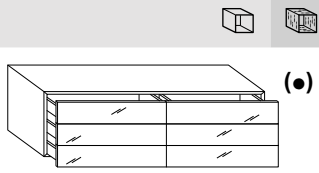
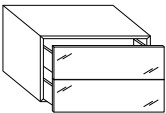
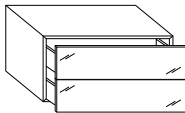
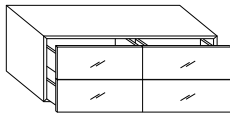
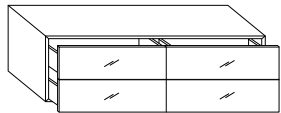
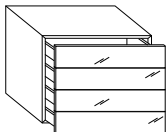
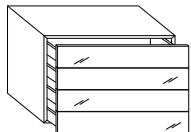
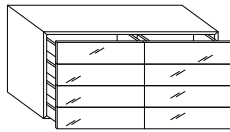
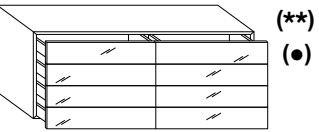
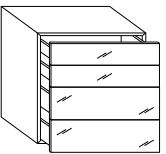
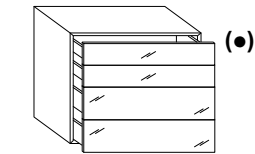
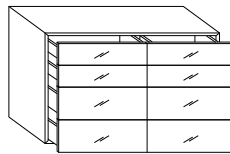
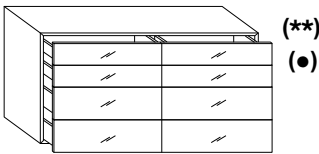
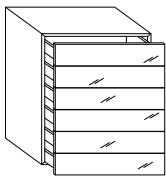
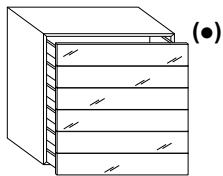
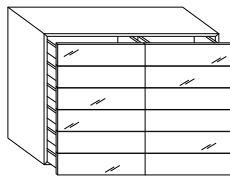
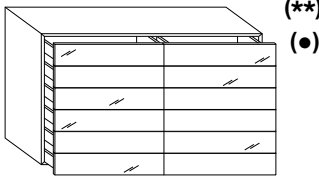
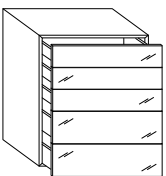
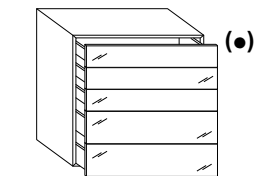
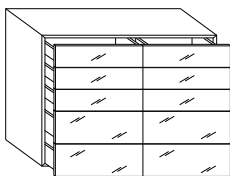
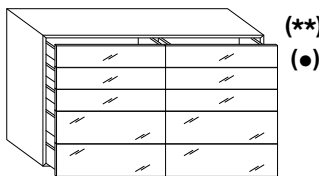

92	110,4	147,2	184
			
T6424	T6425	T6427	T6428
			
T6524	T6525	T6527	T6528
			
T6434	T6435	T6437	T6438
			
T6394	T6395	T6397	T6398
			
T6454	T6455	T6457	T6458
			
T6354	T6355	T6357	T6358

(\*\*) Utilizzabile solo in appoggio a terra.  
 (\*\*) Floor-standing only.

# RACCORDO ANGOLARE//CORNER CONNECTOR

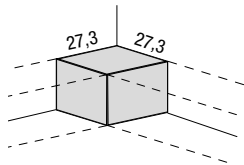
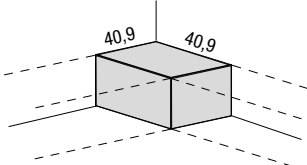
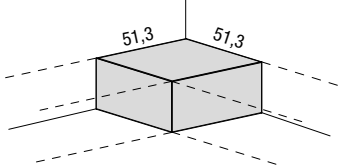
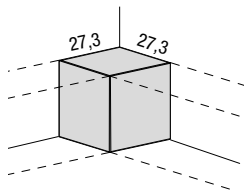
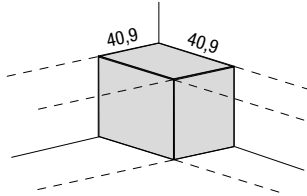
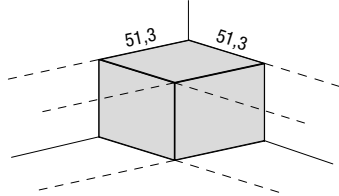
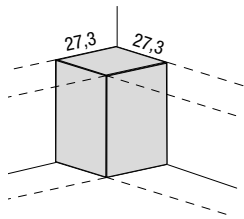
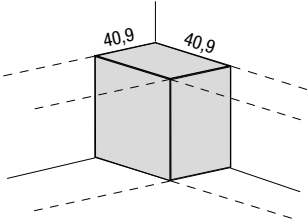
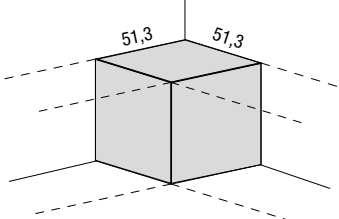
Altezza Height	Per modulo da 27 x 27 For unit measuring 27.0 x 27.0	Per modulo da 40,6 x 40,6 For unit measuring 40.6 x 40.6	Per modulo da 51 x 51 For unit measuring 51.0 x 51.0
<b>18,4</b>			
Laccato//Lacquered	TEA122	TEA144	TEA155
<b>27,6</b>			
Laccato//Lacquered	TEA222	TEA244	TEA255
<b>36,8</b>			
Laccato//Lacquered	TEA322	TEA344	TEA355

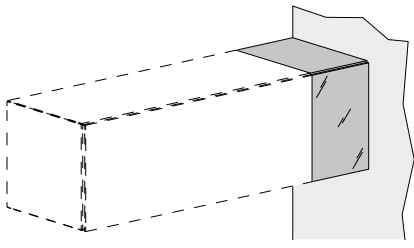
Descrizione//Description	Larghezza Width	Altezza Height	Codice Code	Laccato Lacquered	Vetro lucido o specchio* Polished glass or mirror*	Vetro opaco Matt glass	XGlass lucido o opaco polished or matt
<b>Contenitore di tamponamento con anta fissa</b> <i>Filler storage unit with fixed door</i> 	Min 20 Max 36,7	Min 18,4 Max 73,6	TEA90W				

Per modulo da 27 x 40,6  
For unit measuring 27.0 x 40.6

Per modulo da 27 x 51  
For unit measuring 27.0 x 51.0

Per modulo da 40,6 x 51  
For unit measuring 40.6 x 51.0

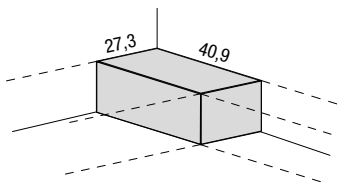

TEA124

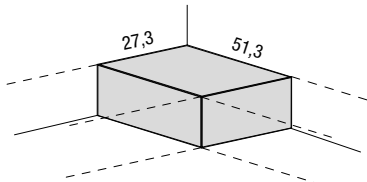

TEA125

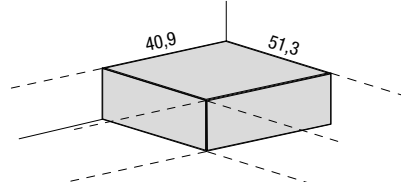

TEA145

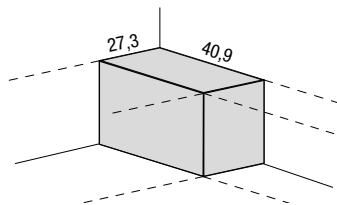

TEA224

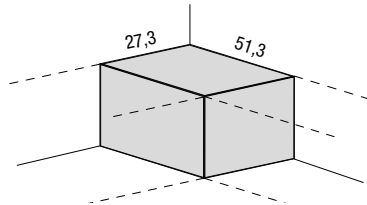

TEA225

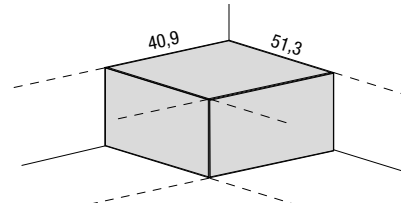

TEA245

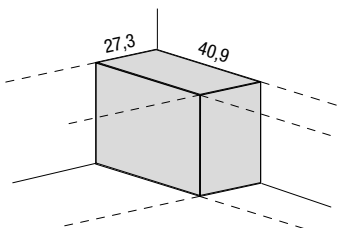

TEA324

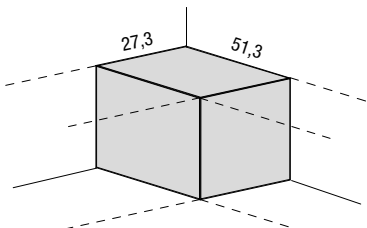

TEA325

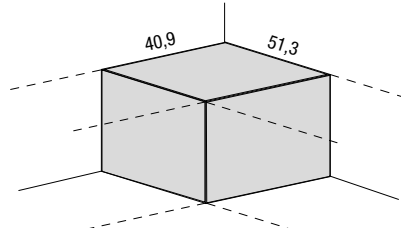

TEA345

**Contenitore sospeso o a terra**  
Corner connector can be used  
either as floor-standing or wall  
hung

# P. 24,8 36e8 GLASS

## Contenitori a giorno in vetro. Struttura:

A: vetro extra-chiaro, B: vetro fumè grigio o vetro fumè bronzo

## Glass open-fronted storage units. Structure:

A: extra-clear glass, B: Grey smoked glass or Bronze smoked glass

Altezza Height	Larghezza Width	36,8		55,2		73,6	
Struttura//Structure		A	B	A	B	A	B
<b>36,8</b>			**				
<b>Schiena//Back</b>							
Vetro lucido o specchio*/Polished glass or mirror*							
Vetro opaco//Matt glass	GSD001			GSD002		GSD003	
XGlass lucido o opaco//Polished or matt XGlass							
<b>36,8</b>					**		
<b>Schiena//Back</b>							
Vetro lucido o specchio*/Polished glass or mirror*							
Vetro opaco//Matt glass				GSD101		GSD102	
XGlass lucido o opaco//Polished or matt XGlass							
<b>36,8</b>					**		
<b>Schiena//Back</b>							
Vetro lucido o specchio*/Polished glass or mirror*							
Vetro opaco//Matt glass				GSD201		GSD202	
XGlass lucido o opaco//Polished or matt XGlass							
<b>36,8</b>					**		
<b>Schiena//Back</b>							
Vetro lucido o specchio*/Polished glass or mirror*							
Vetro opaco//Matt glass				GSD301		GSD302	
XGlass lucido o opaco//Polished or matt XGlass							
<b>36,8</b>					**		
<b>Schiena//Back</b>							
Vetro lucido o specchio*/Polished glass or mirror*							
Vetro opaco//Matt glass				GSD401		GSD402	
XGlass lucido o opaco//Polished or matt XGlass							

\* Specchio: disponibile nelle finiture naturale, fumè grigio o fumè bronzo.









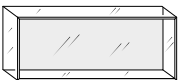

\* Mirror: available in the Naturale, Smoked grey or Smoked bronze finishes.

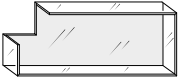
## ILLUMINAZIONE PER CONTENITORI 36E8 GLASS//LIGHTING FOR 36E8 GLASS STORAGE UNITS

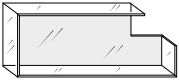
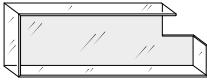
Descrizione//Description	Larghezza Width	Watt	Codice Code	Illuminazione LED LED lighting
<b>Illuminazione LED 3.000°K</b> <b>Applicabile sopra e/o sotto.</b> <b>Alimentatore non incluso.</b> <i>LED lighting 3.000°K</i> <i>Can be applied above and/or below.</i> <i>Power unit not included.</i>	36,8	4,2	CU1605	
	55,2	6,3	CU1610	
	73,6	8,4	CU1615	
	92	10,5	CU1620	
	110,4	12,6	CU1625	
	128,8	14,7	CU1630	
	147,2	16,8	CU1635	
	<b>Alimentatore 24V, 4 uscite</b> <b>Prevedere un alimentatore e un punto luce per ogni LED.</b> <b>Non sono predisposti passaggi di cavi.</b> <i>Power unit 24V, 4 outputs</i> <i>Consider one power unit and one light point for each LED.</i> <i>Not set up for cables to pass through.</i>	<b>Watt</b>		<b>Codice Code</b>
15		CU1715		
30		CU1703		
100		CU1710		
80 W a 110V per mercato USA 80 W with 110V for US market		CU1711		
<b>Radiocomando dimmer</b> <i>Dimmer remote</i>	24V max 144W		CU1801	

42 \*\* Illuminazione non disponibile per mercato USA

\*\* Lighting not available for the American market

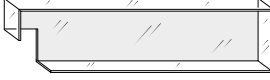
92			110,4			147,2		
A	B		A	B		A	B	
								
GSD004			GSD005			GSD006		
								
GSD103			GSD104			GSD105		
								
GSD203			GSD204			GSD205		
								
GSD303			GSD304			GSD305		
								
GSD403			GSD404			GSD405		

# P. 24,8 36e8 GLASS

## Contenitori a giorno in vetro. Struttura:

A: vetro extra-chiaro, B: vetro fumè grigio o vetro fumè bronzo

## Glass open-fronted storage units. Structure:

A: extra-clear glass, B: Grey smoked glass or Bronze smoked glass

Altezza Height	Larghezza Width	110,4		147,2	
Struttura//Structure		A	B	A	B
<b>55,2</b>					
<b>Schiena//Back</b>					
Vetro lucido o specchio*///Polished glass or mirror*					
Vetro opaco//Matt glass	GSS620			GSS720	
XGlass lucido o opaco//Polished or matt XGlass					
<b>55,2</b>					
<b>Schiena//Back</b>					
Vetro lucido o specchio*///Polished glass or mirror*					
Vetro opaco//Matt glass	GSS621			GSS721	
XGlass lucido o opaco//Polished or matt XGlass					
<b>55,2</b>					
<b>Schiena//Back</b>					
Vetro lucido o specchio*///Polished glass or mirror*					
Vetro opaco//Matt glass	GSS623			GSS723	
XGlass lucido o opaco//Polished or matt XGlass					
<b>55,2</b>					
<b>Schiena//Back</b>					
Vetro lucido o specchio*///Polished glass or mirror*					
Vetro opaco//Matt glass	GSS622			GSS722	
XGlass lucido o opaco//Polished or matt XGlass					

\* Specchio: disponibile nelle finiture naturale, fumè grigio o fumè bronzo.

\* Mirror: available in the Naturale, Smoked grey or Smoked bronze finishes.

## ILLUMINAZIONE PER CONTENITORI 36E8 GLASS//LIGHTING FOR 36E8 GLASS STORAGE UNITS

Descrizione//Description	Larghezza Width	Watt	Codice Code	Illuminazione LED LED lighting
<b>Illuminazione LED 3.000°K</b> <b>Applicabile sopra e/o sotto.</b> <b>Alimentatore non incluso.</b> LED lighting 3.000°K Can be applied above and/or below. Power unit not included.				
		55,2	6,3	CU1610
	110,4	12,6	CU1625	
	147,2	16,8	CU1635	
<b>Alimentatore 24V, 4 uscite</b> <b>Prevedere un alimentatore e un punto luce per ogni LED.</b> <b>Non sono predisposti passaggi di cavi.</b> Power unit 24V, 4 outputs Consider one power unit and one light point for each LED. Not set up for cables to pass through.		<b>Watt</b>	<b>Codice Code</b>	
		15	CU1715	
		30	CU1703	
		100	CU1710	
	80 W a 110V per mercato USA 80 W with 110V for US market		CU1711	
<b>Radiocomando dimmer</b> Dimmer remote		24V max 144W	CU1801	

# P. 24,8 36e8 GLASS

**Contenitori a giorno in vetro. Struttura:**

**A:** vetro extra-chiaro, **B:** vetro fumè grigio o vetro fumè bronzo

**Glass open-fronted storage units. Structure:**

**A:** extra-clear glass, **B:** Grey smoked glass or Bronze smoked glass

Strutturale // Structure	Larghezza Width		36,8		55,2		73,6		92		110,4	
	A	B	A	B	A	B	A	B	A	B	A	B
<b>Altezza Height</b>	<b>55,2</b>											
<b>Schiena // Back</b>												
Vetro lucido o specchio* // Polished glass or mirror*												
Vetro opaco // Matt glass	GSC006		GSC007		GSC008		GSC009		GSC010			
XGlass lucido o opaco // Polished or matt XGlass												
<b>Altezza Height</b>	<b>73,6</b>											
<b>Schiena // Back</b>												
Vetro lucido o specchio* // Polished glass or mirror*												
Vetro opaco // Matt glass	GSC001		GSC003		GSC005							
XGlass lucido o opaco // Polished or matt XGlass												
<b>Altezza Height</b>	<b>110,4</b>											
<b>Schiena // Back</b>												
Vetro lucido o specchio* // Polished glass or mirror*												
Vetro opaco // Matt glass	GSC002		GSC004									
XGlass lucido o opaco // Polished or matt XGlass												

\* Specchio: disponibile nelle finiture naturale, fumè grigio o fumè bronzo.

\* Mirror: available in the Naturale, Smoked grey or Smoked bronze finishes.

## ILLUMINAZIONE PER CONTENITORI 36E8 GLASS // LIGHTING FOR 36E8 GLASS STORAGE UNITS

Descrizione // Description	Larghezza Width	Watt	Codice Code	Illuminazione LED LED lighting
<b>Illuminazione LED 3.000°K</b> Applicabile sopra e/o sotto. Alimentatore non incluso. LED lighting 3.000°K Can be applied above and/or below. Power unit not included.		36,8	4,2	CU1605
	55,2	6,3	CU1610	
	73,6	8,4	CU1615	
	92	10,5	CU1620	
	110,4	12,6	CU1625	
	147,2	16,8	CU1635	
<b>Alimentatore 24V, 4 uscite</b> Prevedere un alimentatore e un punto luce per ogni LED. Non sono predisposti passaggi di cavi. Power unit 24V, 4 outputs Consider one power unit and one light point for each LED. Not set up for cables to pass through.		15	CU1715	
		30	CU1703	
		100	CU1710	
		80 W a 110V per mercato USA 80 W with 110V for US market	CU1711	
<b>Radiocomando dimmer</b> Dimmer remote	24V max 144W		CU1801	

\*\* Illuminazione non disponibile per mercato USA

\*\* Lighting not available for the American market



# P. 38,4 36e8 GLASS

## Contenitori a giorno in vetro. Struttura:

A: vetro extra-chiaro, B: vetro fumè grigio o vetro fumè bronzo

## Glass open-fronted storage units. Structure:

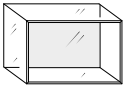

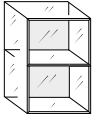
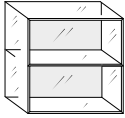
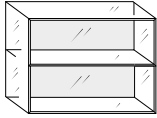
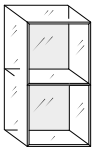
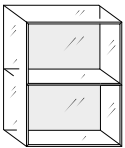
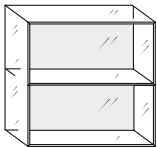
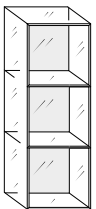
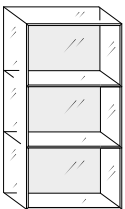
A: extra-clear glass, B: Grey smoked glass or Bronze smoked glass

Altezza Height	Larghezza Width	36,8		55,2		73,6	
Struttura//Structure		A	B	A	B	A	B
<b>36,8</b>	<b>Schiena//Back</b>						
	Vetro lucido o specchio*///Polished glass or mirror*						
	Vetro opaco//Matt glass	GSD801		GSD802		GSD803	
	XGlass lucido o opaco//Polished or matt XGlass						
<b>55,2</b>	<b>Schiena//Back</b>						
	Vetro lucido o specchio*///Polished glass or mirror*						
	Vetro opaco//Matt glass	GSC106		GSC107		GSC108	
	XGlass lucido o opaco//Polished or matt XGlass						
<b>73,6</b>	<b>Schiena//Back</b>						
	Vetro lucido o specchio*///Polished glass or mirror*						
	Vetro opaco//Matt glass	GSC101		GSC103		GSC105	
	XGlass lucido o opaco//Polished or matt XGlass						
<b>110,4</b>	<b>Schiena//Back</b>						
	Vetro lucido o specchio*///Polished glass or mirror*						
	Vetro opaco//Matt glass	GSC102		GSC104			
	XGlass lucido o opaco//Polished or matt XGlass						

\* Specchio: disponibile nelle finiture naturale, fumè grigio o fumè bronzo.

\* Mirror: available in the Naturale, Smoked grey or Smoked bronze finishes.

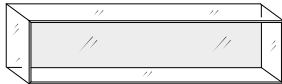

92		110,4		147,2	
A	B	A	B	A	B
					
GSD804		GSD805		GSD806	

### ILLUMINAZIONE PER CONTENITORI 36E8 GLASS//LIGHTING FOR 36E8 GLASS STORAGE UNITS

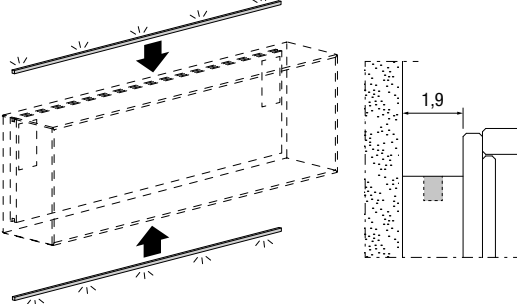
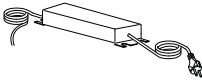
Descrizione//Description	Larghezza Width	Watt	Codice Code	Illuminazione LED LED lighting
<p><b>Illuminazione LED 3.000°K</b>  <b>Applicabile sopra e/o sotto.</b>  <b>Alimentatore non incluso.</b>  <i>LED lighting 3.000°K</i>  <i>Can be applied above and/or below.</i>  <i>Power unit not included.</i></p> 	36,8	4,2	CU1605	
	55,2	6,3	CU1610	
	73,6	8,4	CU1615	
	92	10,5	CU1620	
	110,4	12,6	CU1625	
	147,2	16,8	CU1635	
	<p><b>Alimentatore 24V, 4 uscite</b>  <b>Prevedere un alimentatore e un punto luce per ogni LED.</b>  <b>Non sono predisposti passaggi di cavi.</b>  <i>Power unit 24V, 4 outputs</i>  <i>Consider one power unit and one light point for each LED.</i>  <i>Not set up for cables to pass through.</i></p> 		15	CU1715
		30	CU1703	
		100	CU1710	
		80 W a 110V per mercato USA 80 W with 110V for US market	CU1711	
<p><b>Radiocomando dimmer</b>  <i>Dimmer remote</i></p>		24V max 144W	CU1801	

# 36e8 WALL PANEL

Indicare finitura specchio: naturale, fumè grigio o fumè bronzo  
Please specify the mirror finish: Naturale, Smoked Grey or Smoked Bronze

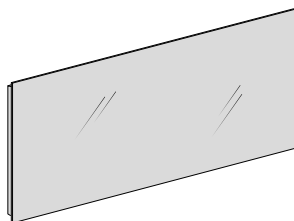

Le misure sono nominali in quanto prevedono un montaggio con fuga di 0,3 cm tra i pannelli  
The sizes are nominal since they require an installation with a 0,3 cm gap between the panels

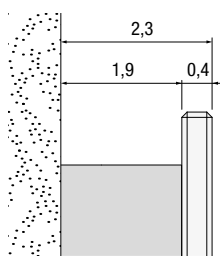

Vetro/XGlass  
Glass/XGlass

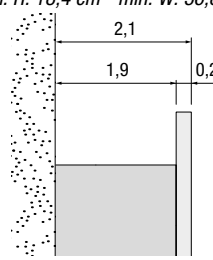

Metallo laccato  
Lacquered metal

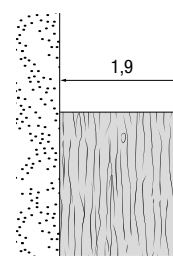

Rovere Gentle  
Gentle Oak

Riduzione in larghezza e altezza senza maggiorazione di prezzo  
H min 18,4 cm - L min 36,8 cm  
Width and height reduction at no extra cost  
Min. H. 18,4 cm - min. W. 36,8 cm

Descrizione//Description	Altezza Height	Larghezza Width	Codice Code	Specchio Mirror	Metallo laccato Lacquered metal	Vetro lucido Polished glass	Vetro opaco Matt glass	XGlass lucido o opaco polished or matt	Rovere Gentle Gentle Oak
	18,4	36,8**	TF0012						
		55,2*	TF0013						
		73,6	TF0014						
		92	TF0015						
		110,4	TF0016						
		147,2	TF0017						
		184	TF0018						
	27,6	220,8	TF0019						
		36,8*	TF0072						
		55,2	TF0073						
		73,6	TF0074						
		92	TF0075						
		110,4	TF0076						
		147,2	TF0077						
	36,8	184	TF0078						
		220,8	TF0079						
		36,8*	TF0022						
		55,2	TF0023						
		73,6	TF0024						
		92	TF0025						
		110,4	TF0026						
	55,2	147,2	TF0027						
		184	TF0028						
		220,8	TF0029						
		36,8*	TF0032						-
		55,2	TF0033						-
		73,6	TF0034						-
		92	TF0035						-
	73,6	110,4	TF0036					-	
		147,2	TF0037					-	
		184	TF0038					-	
		220,8	TF0039					-	
		36,8*	TF0042					-	
		55,2	TF0043					-	
		73,6	TF0044					-	
	92	92	TF0045					-	
		110,4	TF0046					-	
		147,2	TF0047					-	
		184	TF0048					-	
		220,8	TF0049					-	
		36,8	TF0052					-	
		55,2	TF0053					-	
	110,4	73,6	TF0054					-	
		92	TF0055					-	
		110,4	TF0056					-	
		147,2	TF0057					-	
		36,8	TF0062					-	
		55,2	TF0063					-	
		73,6	TF0064					-	

# 36e8\_WALL PANEL

Descrizione//Description	Altezza Height	Larghezza Width	Codice Code	Specchio* Mirror*	Metallo laccato Lacquered metal	Vetro lucido Polished glass	Vetro opaco Matt glass	XGlass lucido o opaco Polished or matt XGlass
<p>Larghezza//Width</p> <p>147,2</p>	147,2	36,8	TF0102					
		55,2	TF0103					
		73,6	TF0104					
<p>Larghezza//Width</p> <p>184</p>	184	36,8	TF0112					
		55,2	TF0113					
		73,6	TF0114					
<p>Larghezza//Width</p> <p>220,8</p>	220,8	36,8	TF0122					
		55,2	TF0123					
		73,6	TF0124					
Maggiorazione per foro grezzo Surcharge for rough holes			RID263					
<b>Appendiabiti</b> Clotheshanger  **LED non disponibile per H 18,4 **LED not available for H 18,4	2,1			<b>Altezza</b> Height	<b>Larghezza</b> Width	<b>Codice</b> Code	<b>Metallo laccato</b> Lacquered metal	<b>Metallo verniciato Peltro/Titanio</b> Metal painted Peltro/Titanio
		18,4**	36,8	TH3001				
			55,2	TH3002				
			73,6	TH3003				

## ILLUMINAZIONE PER 36e8 WALL PANEL//LIGHTING FOR 36e8 WALL PANEL

Descrizione//Description	Larghezza Width	Watt	Codice Code	Illuminazione LED LED lighting
<p><b>Illuminazione LED 3.000°K</b> Applicabile sopra e/o sotto. Il LED si applica al pannello strutturale. Non applicabile a 36e8 Wall Panel in Rovere Gentile. Alimentatore non incluso. LED lighting 3.000°K Can be applied above and/or below. The LED is applied to the structural panel. Cannot be applied to 36e8 Wall Panel in Gentle oak. Power unit not included.</p> <p><b>LED</b> Vetro, XGlass, Specchio Glass, XGlass, Mirror</p> <p><b>Pannello strutturale bordo Titanio</b> Structural panel Titanio edge</p> <p><b>LED</b> Metallo Metal</p> <p><b>Pannello strutturale bordo Titanio</b> Structural panel Titanio edge</p>	36,8	4,2	CU1605	
	55,2	6,3	CU1610	
	73,6	8,4	CU1615	
	92	10,5	CU1620	
	110,4	12,6	CU1625	
	147,2	16,8	CU1635	
	184	21	CU1645	
	220,8	25,2	CU1655	
<p><b>Alimentatore 24V, 4 uscite</b> Prevedere un alimentatore e un punto luce per ogni pannello. Non sono predisposti passaggi di cavi. Power unit 24V, 4 outputs Consider one power unit and one light point for each panel. Not set up for cables to pass through.</p>	<b>Watt</b>		<b>Codice</b> Code	<b>Illuminazione LED</b> LED lighting
	15		CU1715	
	30		CU1703	
	100		CU1710	
	80 W a 110V per mercato USA 80 W with 110V for US market		CU1711	
<p><b>Radiocomando dimmer</b> Dimmer remote</p>	24V max 144W		CU1801	

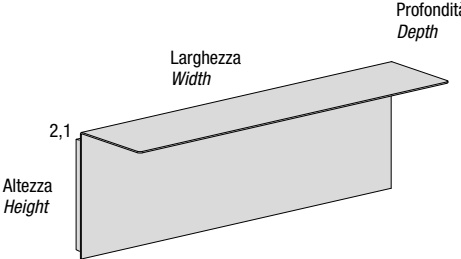
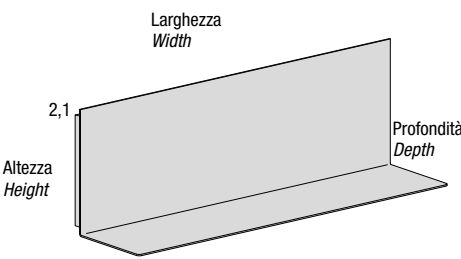
Descrizione//Description	Profondità Depth	Altezza Height	Larghezza Width	Codice Code	Metallo laccato Lacquered metal	Metallo verniciato Peltro/Titanio Metal painted Peltro/Titanio	
<b>Mensola alta</b> High shelf  	13,6	18,4	36,8*	TH2010			
			55,2*	TH2011			
			73,6	TH2012			
			92	TH2013			
			110,4	TH2014			
			147,2	TH2015			
			184	TH2016			
		220,8	TH2017				
		36,8*	TH2110				
		55,2	TH2111				
		73,6	TH2112				
		92	TH2113				
		110,4	TH2114				
		147,2	TH2115				
	184	TH2116					
	220,8	TH2117					
	24,8	36,8	36,8*	TH5110			
	55,2		TH5111				
	73,6		TH5112				
	92		TH5113				
	110,4		TH5114				
	147,2		TH5115				
	184		TH5116				
	220,8	TH5117					
	Maggiorazione per taglio in larghezza Surcharge for cutting in width					+30%	
	LED non disponibile per H 18,4 x L 36,8 LED not available for H 18,4 x W 36,8						
	<b>Mensola bassa</b> Low shelf  	13,6	18,4	36,8*	TH2210		
				55,2*	TH2211		
73,6				TH2212			
92				TH2213			
110,4				TH2214			
147,2				TH2215			
184				TH2216			
220,8			TH2217				
36,8*			TH2310				
55,2			TH2311				
73,6			TH2312				
92			TH2313				
110,4			TH2314				
147,2			TH2315				
184		TH2316					
220,8		TH2317					
24,8		36,8	36,8*	TH5310			
55,2			TH5311				
73,6			TH5312				
92			TH5313				
110,4			TH5314				
147,2			TH5315				
184			TH5316				
220,8		TH5317					
Maggiorazione per taglio in larghezza Surcharge for cutting in width					+30%		
LED non disponibile per H 18,4 x L 36,8 LED not available for H 18,4 x W 36,8							

\* Illuminazione non disponibile per mercato USA  
 \* Lighting not available for the American market

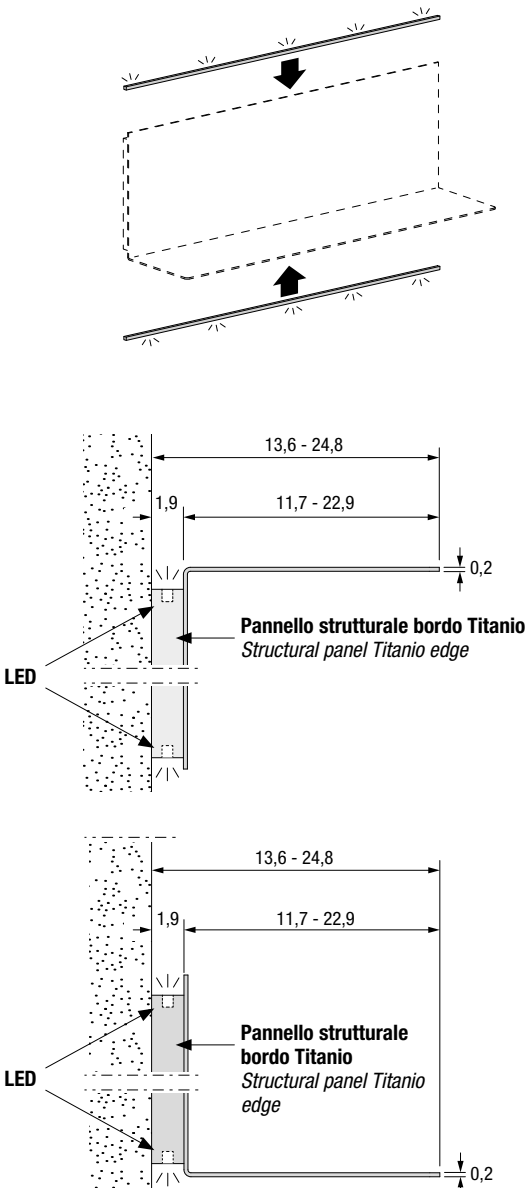
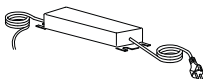
Descrizione//Description	Larghezza Width	Watt	Codice Code	Illuminazione LED LED lighting																								
<p><b>illuminazione LED 3.000°K</b>  <b>Applicabile sopra e/o sotto.</b>  <b>Il LED si applica al pannello strutturale.</b>  <b>Alimentatore non incluso.</b>  <i>LED lighting 3.000°K</i>  <i>Can be applied above and/or below.</i>  <i>The LED is applied to the structural panel.</i>  <i>Power unit not included.</i></p> 	<table border="1"> <tr><td>36,8</td><td>4,2</td><td>CU1605</td></tr> <tr><td>55,2</td><td>6,3</td><td>CU1610</td></tr> <tr><td>73,6</td><td>8,4</td><td>CU1615</td></tr> <tr><td>92</td><td>10,5</td><td>CU1620</td></tr> <tr><td>110,4</td><td>12,6</td><td>CU1625</td></tr> <tr><td>147,2</td><td>16,8</td><td>CU1635</td></tr> <tr><td>184</td><td>21</td><td>CU1645</td></tr> <tr><td>220,8</td><td>25,2</td><td>CU1655</td></tr> </table>	36,8	4,2	CU1605	55,2	6,3	CU1610	73,6	8,4	CU1615	92	10,5	CU1620	110,4	12,6	CU1625	147,2	16,8	CU1635	184	21	CU1645	220,8	25,2	CU1655			
36,8	4,2	CU1605																										
55,2	6,3	CU1610																										
73,6	8,4	CU1615																										
92	10,5	CU1620																										
110,4	12,6	CU1625																										
147,2	16,8	CU1635																										
184	21	CU1645																										
220,8	25,2	CU1655																										
<p><b>Alimentatore 24V, 4 uscite</b>                      Prevedere un alimentatore e un punto luce per ogni LED.                      Non sono predisposti passaggi di cavi.  <i>Power unit 24V, 4 outputs</i>  <i>Consider one power unit and one light point for each LED.</i>  <i>Not set up for cables to pass through.</i></p> 	<table border="1"> <tr> <th>Watt</th> <th>Codice Code</th> <th>Alimentatore Power supply</th> </tr> <tr> <td>30</td> <td>CU1703</td> <td></td> </tr> <tr> <td>100</td> <td>CU1710</td> <td></td> </tr> </table>	Watt	Codice Code	Alimentatore Power supply	30	CU1703		100	CU1710																			
Watt	Codice Code	Alimentatore Power supply																										
30	CU1703																											
100	CU1710																											
<p><b>Radiocomando dimmer</b>                      Dimmer remote</p>	<p>24V max 144W</p>		<p>CU1801</p>																									

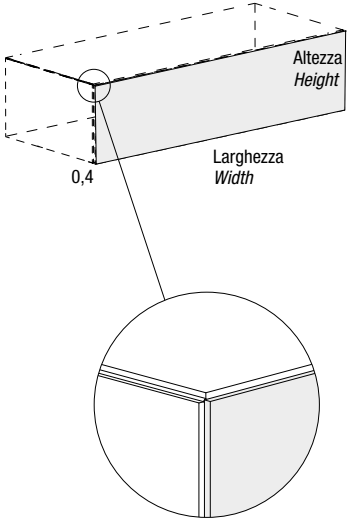
Descrizione//Description	Altezza Height	Larghezza Width	Codice Code	Laccato Lacquered	Vetro lucido o specchio* Polished glass or mirror*	Vetro opaco Matt glass	XGlass lucido o opaco polished or matt	Rovere Gentle Gentle Oak
<b>Pannello bifacciale sp. 0,4 cm</b> <i>Double-sided panel thk 0,4 cm</i> 	13,8	36,8	ATY081					
		55,2	ATY083					
		73,6	ATY084					
		92	ATY085					
		110,4	ATY086					
		147,2	ATY087					
		184	ATY088					
	18,4	36,8	ATY010					
		55,2	ATY011					
		73,6	ATY012					
		92	ATY013					
		110,4	ATY014					
		147,2	ATY015					
		184	ATY016					
	27,6	36,8	ATY089					
		55,2	ATY090					
		73,6	ATY091					
		92	ATY092					
		110,4	ATY093					
		147,2	ATY094					
		184	ATY095					
	36,8	36,8	ATY020					
		55,2	ATY021					
		73,6	ATY022					
		92	ATY023					
		110,4	ATY024					
		147,2	ATY025					
		184	ATY026					
	55,2	220,8	ATY027					
		36,8	ATY030					
		55,2	ATY031					
		73,6	ATY032					
		110,4	ATY034					
		147,2	ATY035					
		184	ATY036					
	73,6	220,8	ATY037					
		36,8	ATY040					
		55,2	ATY041					
		73,6	ATY042					
		110,4	ATY043					
		147,2	ATY044					
		184	ATY046					
		220,8	ATY047					

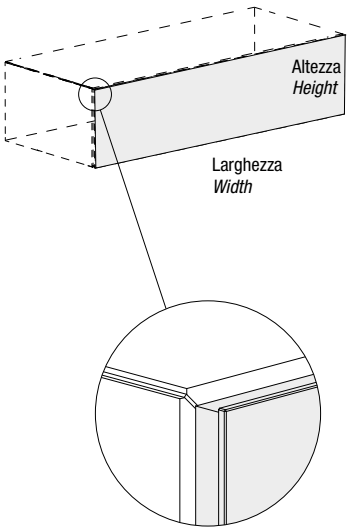
Descrizione//Description	Altezza Height	Larghezza Width	Codice Code	Laccato Lacquered	Vetro lucido o specchio* Polished glass or mirror*	Vetro opaco Matt glass	XGlass lucido o opaco polished or matt	Wildwood
<b>Anta fissa per elemento bifacciale - sp. 2 cm</b> Fixed door for double-sided unit - thk 2 cm  	18,4	36,8	ATX011					
		55,2	ATX012					
		73,6	ATX013					
		92	ATX014					
		110,4	ATX015					
		147,2	ATX016					
	27,6	184	ATX017					
		36,8	ATX094					
		55,2	ATX095					
		73,6	ATX096					
		92	ATX097					
		110,4	ATX098					
	36,8	147,2	ATX099					
		184	ATX100					
		36,8	ATX021					
		55,2	ATX022					
		73,6	ATX023					
		92	ATX024					
	55,2	110,4	ATX025					
		147,2	ATX026					
		184	ATX027					
		220,8	ATX028					
		36,8	ATX031					
		55,2	ATX032					
	73,6	73,6	ATX033					
		110,4	ATX035					
		36,8	ATX041					
		55,2	ATX042					
		73,6	ATX043					
		110,4	ATX045					
	92	147,2	ATX046					
		36,8	ATX051					
		55,2	ATX052					
		73,6	ATX053					
		36,8	ATX061					
		55,2	ATX062					
	110,4	73,6	ATX063					
		36,8	ATX071					
		147,2	ATX072					
		73,6	ATX073					
		36,8	ATX081					
		55,2	ATX082					
147,2	73,6	ATX083						
	36,8	ATX091						
	55,2	ATX092						
	73,6	ATX093						
	36,8	ATX091						
	55,2	ATX092						
220,8	73,6	ATX093						
	36,8	ATX091						

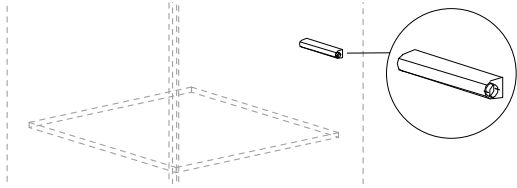
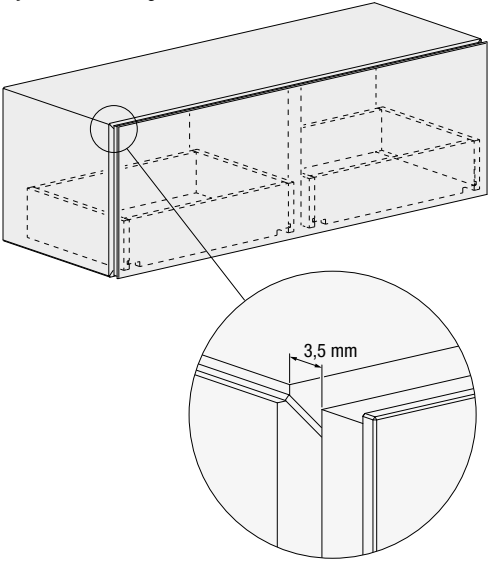
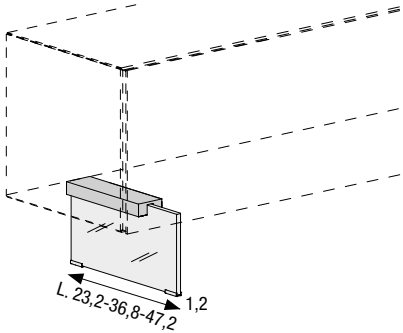
Descrizione//Description				Codice Code	Maggiorazione Extra Cost	
<p><b>Meccanismo di apertura push-pull per contenitori orizzontali vasistas/ribalta e per contenitori verticali</b>  <i>Push-pull opening mechanism for top hung/bottom hung horizontal storage units and for vertical storage units</i></p> 				TER053		
<p><b>Maggiorazione per apertura push-pull per un cassetto o un cestone</b>  <b>Solo per 36e8_storage</b>  <i>Surcharge for push-pull opening for drawer or deep drawer</i>  <i>Only for 36e8_storage</i></p>  <p><b>* Solo nei cestoni H 36,8 L 110,4 viene aggiunto un divisorio</b>  <i>* A partition is added only to H 36.8 W 110.4 deep drawers</i></p>	<p><b>Larghezza contenitore</b>  <i>Storage unit width</i></p>	<p><b>Codice Code</b></p>	<p><b>Maggiorazione Extra Cost</b></p>	<p>Per 1 cassetto o cestone 36,8 - 55,2 - 73,6  <i>For 1 drawer or deep drawer 36.8 - 55.2 - 73.6</i></p>	RID264	
<p>Per 1 cassetto o cestone 110,4 *  <i>For 1 drawer or deep drawer 110.4 *</i></p>				RID265		
<p>Per 1 cassetto o cestone 147,2  <i>For 1 drawer or deep drawer 147.2</i></p>				RID266		
<p><b>Sostegno vetro</b>  <i>Glass support</i></p>  <p>Le altezze reali dei sostegni sono maggiorate di 1,7 cm  <i>The supports' real heights are increased by 1.7 cm</i></p>	<p><b>P. contenitore</b>  <i>Storage unit D.</i></p>	<p><b>Larghezza</b>  <i>Width</i></p>	<p><b>Altezza</b>  <i>Height</i></p>	<p><b>Codice Code</b></p>	<p><b>Vetro extra-chiaro o fumè grigio</b>  <i>Extra-clear or smoked grey glass</i></p>	
<p>27</p>	<p>23,2</p>	<p>9,2 18,4 27,6 36,8</p>	<p>TER530 TER495 TER496 TER497</p>			
<p>40,6</p>	<p>36,8</p>	<p>9,2 18,4 27,6 36,8</p>	<p>TER531 TER505 TER506 TER507</p>			
<p>51</p>	<p>47,2</p>	<p>9,2 18,4 27,6 36,8</p>	<p>TER533 TER535 TER536 TER537</p>			

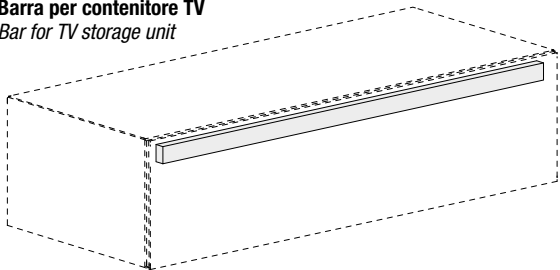
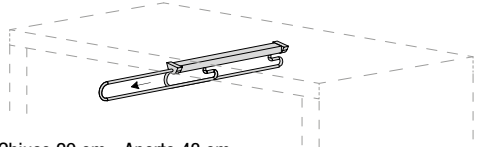
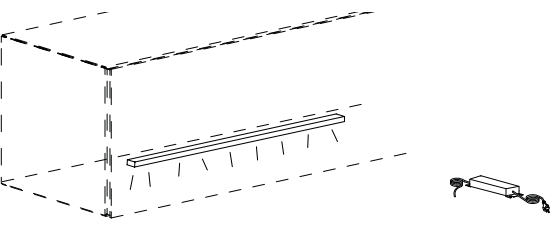

Descrizione/Description	Altezza Height	Larghezza Width	Codice Code	Alluminio Aluminium	
<p><b>Barra per contenitore TV</b> <i>Bar for TV storage unit</i></p>  <p>(*) Fornite a coppia per contenitori a ribalta H36,8 (*) <i>Supplied in pairs for bottom-hung storage units, H36,8</i></p>	3	73,6	TER6090		
		92	TER6091		
		110,4	TER6092		
		147,2 (*)	TER6093		
		184 (*)	TER6094		
		220,8 (*)	TER6095		
<p><b>Appendiabiti estraibile per contenitore verticale P. 40,6</b> <i>Pull-out clothes hanger in aluminium for D. 40,6</i></p>  <p>Chiuso 29 cm - Aperto 43 cm <i>Closed 29 cm - Open 43 cm</i></p>			Codice Code	Alluminio Aluminium	
			TER005		
<p><b>Illuminazione sottopensile</b> <b>LED da incasso, accensione touch system, luce dimerabile 3000°K</b> <i>Lighting under cabinet</i> <i>Recessed LEDs, touch system for switching on/off, 3000°K dimmable light</i></p>  <p>Alimentatore 24V, 6 uscite, max 30 Watt (non incluso) <i>Power unit 24V, 6 outputs, max 30 Watt (not included)</i></p>		Larghezza Width	Potenza Power	Codice Code	Alluminio Aluminium
		50	2,4 Watt	CU0634	
		75	4,1 Watt	CU0635	
		100	5,8 Watt	CU0636	
		Alimentatore <i>Power supply</i>	30 Watt	CU0625	

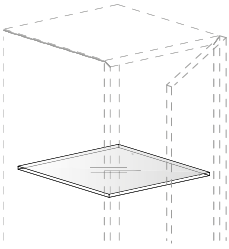
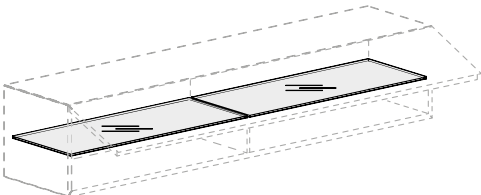
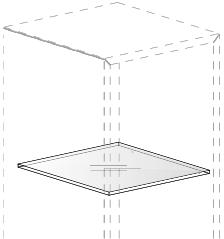
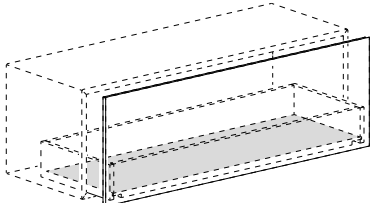
Descrizione//Description	P. contenitore Storage unit D.	L. contenitore Storage unit W.	P. ripiano Shelf D.	Codice Code	Vetro trasparente Clear glass	
<b>Ripiani in appoggio per contenitori verticali con anta</b> <i>Propped shelving for vertical storage units with door</i> 	27	36,8	21,3	TER071		
		55,2	21,3	TER085		
		73,6	21,3	TER072		
	40,6	36,8	34,9	TER011		
		55,2	34,9	TER086		
		73,6	34,9	TER012		
	<b>Ripiani in appoggio per contenitori orizzontali con anta</b> <i>Propped shelving for horizontal storage units with door</i>  <p><b>Non utilizzabile in contenitori a ribalta</b>  <i>Not available for bottom hung opening units</i>  <b>*2 ripiani interni</b>  <i>*2 internal shelves</i></p>	27	36,8	12	TER075	
55,2			12	TER082		
73,6			12	TER076		
92			12	TER077		
110,4			12	TER078		
147,2*			12	TER079		
184*			12	TER080		
40,6		220,8*	12	TER081		
		36,8	25	TER065		
		55,2	25	TER095		
		73,6	25	TER066		
		92	25	TER073		
		110,4	25	TER067		
		147,2*	25	TER068		
51		184*	25	TER069		
		220,8*	25	TER070		
		36,8	40	TER090		
		55,2	40	TER096		
		73,6	40	TER091		
		110,4	40	TER092		
<b>Ripiani fissi per contenitori a giorno verticali</b> <i>Fixed shelves for open vertical storage units</i>  <p>ATTENZIONE: per contenitori con schiene in vetro prevedere un costo extra di max:  <i>WARNING: for storage units with glass backs, consider an extra cost of max:</i></p>	18	36,8	14,5	SBM0018		
		55,2	14,5	SBM0019		
		73,6	14,5	SBM0020		
	24,8	36,8	19,3	SBM0022		
		73,6	19,3	SBM0023		
	38,4	36,8	28,9	SBM0025		
		73,6	28,9	SBM0026		
	RID016					
	<b>Fondi in vetro per interno cassetto e/o cestone</b> <i>Glass bottoms for standard/large drawer inside</i>  <p><b>*Previsti 1 o 2 fondi in base all'articolo</b>  <i>*Consider 1 or 2 bottoms, depending on the item</i>  <b>**Previsti 2 fondi</b>  <i>**Consider 2 bottoms</i></p>	40,6	36,8	TER7201		
			55,2	TER7202		
51		73,6	TER7203			
		110,4*	TER7204			
		147,2**	TER7205			
		184**	TER7206			
		36,8	TER7211			
		55,2	TER7212			
51		73,6	TER7213			
		110,4*	TER7214			
		147,2**	TER7215			
		184**	TER7216			

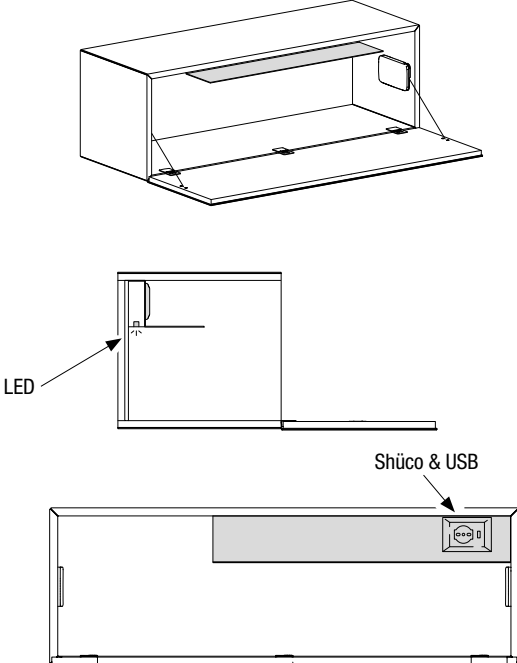
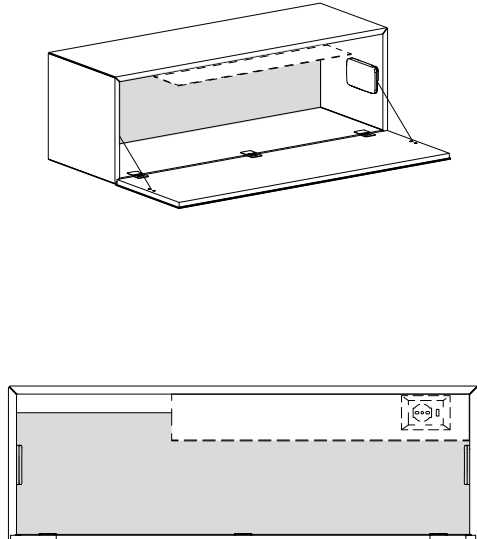
Descrizione//Description	Altezza Height	Larghezza Width	Profondità Depth	Codice Code	Metallo** Metal**
<p><b>Ripiano accessorizzato per scrittoio 36e8</b>                      Il ripiano include:                      - illuminazione interna (LED da incasso, accensione touch system, luce dimmerabile 3000°K),                      - alimentatore (12V, 6 uscite max 30W),                      - plug presa elettrica (uscita USB 5V e Schuko, max 5W).                      Utilizzabile in contenitori da 92 - 110,4 - 147,2 - 184 - 220,8</p> <p><b>Accessorised shelf for 36e8 desk</b>                      The shelf includes:                      - internal lighting (built-in LED, touch system, dimmable light 3000°K),                      - power unit (12V, 6 outputs, max 30W),                      - plug electric socket (USB 5V and Schuko, max 5W).                      Usable in storage units measuring 92 - 110,4 - 147,2 - 184 - 220,8</p>  <p><b>**Disponibile nelle finiture Peltro steel o Titanio steel</b>                      **Available in the Peltro Steel or Titanio Steel finishes</p>	11	70,7	19,8	TER7301	
<p><b>Schienale vetro</b>                      Glass back</p>  <p><b>***Prezzo schiena singola, prevedere 2 schiene per contenitore completo</b>                      ***Price for single back, consider 2 backs for full storage unit</p>	36,8			<p><b>Altezza Height</b></p> <p><b>Larghezza Width</b></p> <p><b>Codice Code</b></p> <p><b>Vetro lucido o specchio* Polished glass or mirror*</b></p> <p><b>Vetro opaco Matt glass</b></p> <p><b>XGlass</b></p>	
		36,8		TER7401	
		55,2		TER7402	
		73,6		TER7403	
		92		TER7404	
		110,4		TER7405	
		147,2***		TER7406	
		184***		TER7407	
		220,4***		TER7408	

\*Specchio: disponibile nelle finiture naturale, fumè grigio o fumè bronzo.  
 \*Mirror: available in the Naturale, Smoked grey or Smoked bronze finishes.

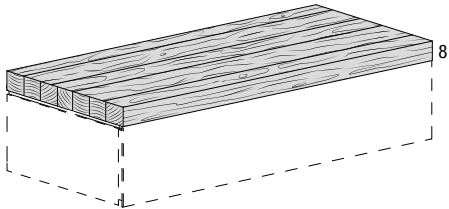
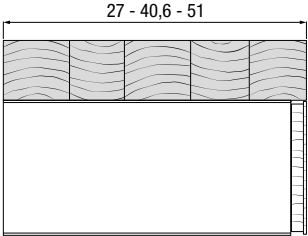
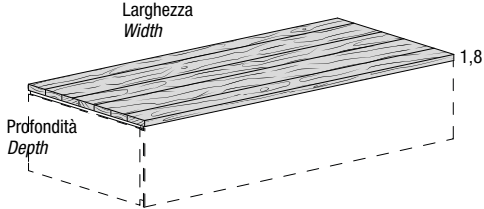
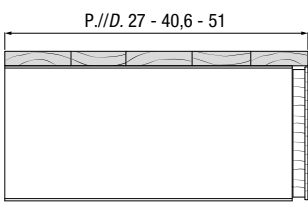
Descrizione//Description	Profondità Depth	Larghezza Width	Codice Code	Wildwood
<p><b>Top Wildwood sp. 8 cm</b> Wildwood top, thk 8 cm</p>  	27	55,2	TBW2001	
		73,6	TBW2002	
		92	TBW2003	
		110,4	TBW2004	
		128,8	TBW2005	
		147,2	TBW2006	
		165,6	TBW2007	
		184	TBW2008	
		202,4	TBW2009	
		220,8	TBW2010	
		239,2	TBW2011	
		257,6	TBW2012	
		276	TBW2013	
		294,4	TBW2014	
		40,6	55,2	TBW2101
	73,6		TBW2102	
	92		TBW2103	
	110,4		TBW2104	
	128,8		TBW2105	
	147,2		TBW2106	
	165,6		TBW2107	
	184		TBW2108	
	202,4		TBW2109	
	220,8		TBW2110	
	239,2		TBW2111	
	257,6		TBW2112	
	276		TBW2113	
	294,4		TBW2114	
	51		55,2	TBW2201
		73,6	TBW2202	
		92	TBW2203	
		110,4	TBW2204	
		128,8	TBW2205	
147,2		TBW2206		
165,6		TBW2207		
184		TBW2208		
202,4		TBW2209		
220,8		TBW2210		
239,2		TBW2211		
257,6		TBW2212		
276		TBW2213		
294,4		TBW2214		
				<b>Maggiorazione Extra Cost</b>
Fori grezzi incasso//Built-in rough holes			RID251	
<p><b>Top Wildwood sp. 1,8 cm</b> Wildwood top, thk 1,8 cm Prezzi al metro lineare Prices per linear metre</p>  	<b>Profondità Depth</b>	<b>Larghezza Width</b>	<b>Codice Code</b>	<b>Wildwood</b>
	27	Fino a//up to 294,4	TBW32	
	40,6	Fino a//up to 294,4	TBW34	
	51	Fino a//up to 294,4	TBW35	
				<b>Maggiorazione Extra Cost</b>
Fori grezzi incasso//Built-in rough holes			RID251	

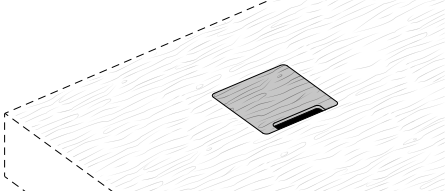
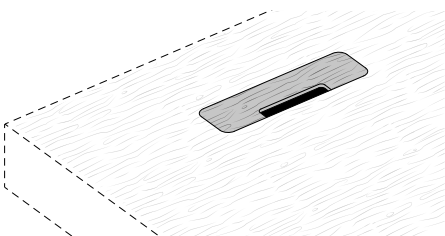
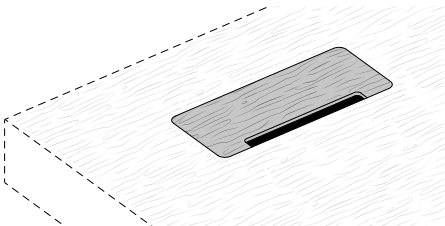
Descrizione/Description	Larghezza Width	Profondità Depth	Codice Code	Wildwood
<p><b>Passacavi quadrato in Wildwood per top sp. 1,8 e 8 cm, tavoli e mensole.</b>  <i>Square cableway in Wildwood for tops 1.8 and 8 cm thick, tables and shelves.</i></p> <p>Il tappo non è ricavato dal top o dal tavolo quindi la venatura e la tinta non corrispondono.  <i>The plug is not cut from the top or the table so the grain and stain do not match.</i></p> 	10	10	TER035	
<p><b>Passacavi rettangolare in Wildwood per top sp. 1,8 e 8 cm, tavoli e mensole.</b>  <i>Rectangular cableway in Wildwood for tops 1.8 and 8 cm thick, tables and shelves.</i></p> <p>Il tappo non è ricavato dal top o dal tavolo quindi la venatura e la tinta non corrispondono.  <i>The plug is not cut from the top or the table so the grain and stain do not match.</i></p> 	18	5	TER036	
<p><b>Passacavi rettangolare in Wildwood per top sp. 1,8 e 8 cm, tavoli e mensole.</b>  <i>Rectangular cableway in Wildwood for tops 1.8 and 8 cm thick, tables and shelves.</i></p> <p>Il tappo non è ricavato dal top o dal tavolo quindi la venatura e la tinta non corrispondono.  <i>The plug is not cut from the top or the table so the grain and stain do not match.</i></p> 	24	10	TER037	

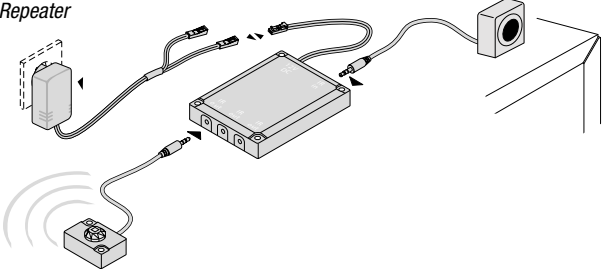
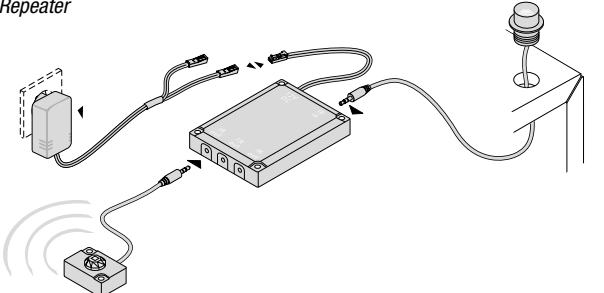
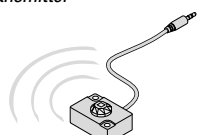
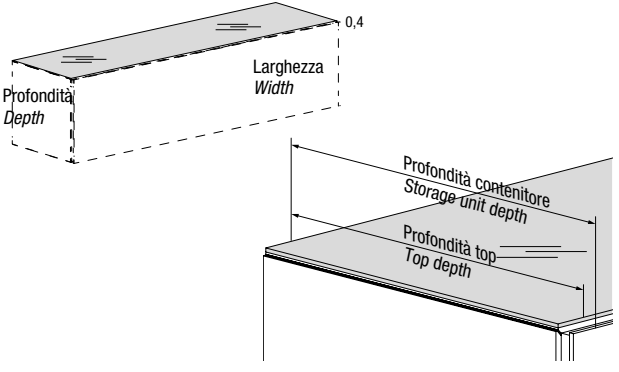
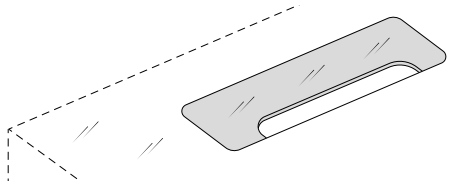
Descrizione//Description			Codice Code	Kit Kit		
<p><b>Ripetitore IR</b> <i>IR Repeater</i></p> 			TER0070			
<p><b>Ripetitore IR</b> <i>IR Repeater</i></p> 			TER0072			
<p><b>Trasmettitore</b> <i>Transmitter</i></p> 			TER0071			
<p><b>Top in vetro sp. 0,4 cm</b> <b>Prezzi al metro lineare</b> Larghezza max 320 cm</p> <p><i>Glass top, 0.4 cm thick</i> <i>Prices per linear metre</i> <i>Max. width 320 cm</i></p>  <p>Il top in vetro ha una larghezza di 0,3 cm minore del contenitore <i>The glass top is 0,3 cm narrower than the storage unit</i></p>	<b>Profondità contenitore</b> <i>Storage unit depth</i>	<b>Profondità top</b> <i>Top depth</i>	<b>Codice Code</b>	<b>Vetro lucido o specchio*</b> <i>Polished glass or mirror*</i>	<b>Vetro opaco</b> <i>Matt glass</i>	<b>XGlass lucido o opaco</b> <i>polished or matt</i>
	27	24,8	TER703			
	40,6	38,4	TER704			
	51	48,8	TER705			
	Maggiorazione per foro passacavi <i>Extra cost for cable hole</i>		RID018			
<p><b>Passacavi in vetro integrato al top</b> <i>Glass cableway built into the top</i></p> 	<b>Larghezza</b> <i>Width</i>	<b>Profondità</b> <i>Depth</i>	<b>Codice Code</b>	<b>Vetro Glass</b>		
	20,5	7	D21006			

## ACCESSORI//ACCESSORIES

Passacavi non posizionabile sopra divisori interni.//Cableways cannot be placed on top of internal partitions.

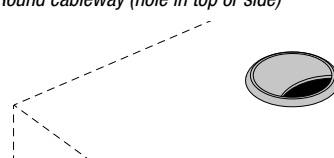
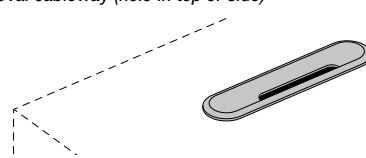
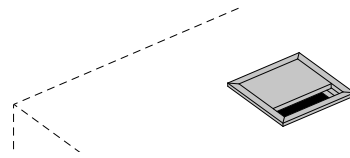
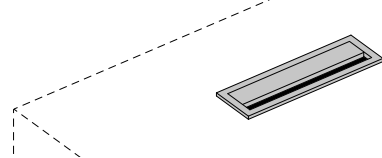
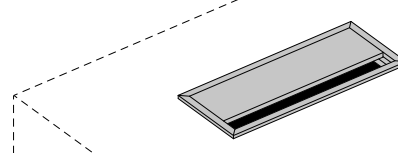
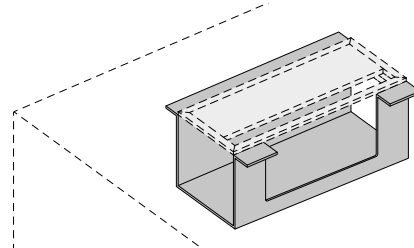
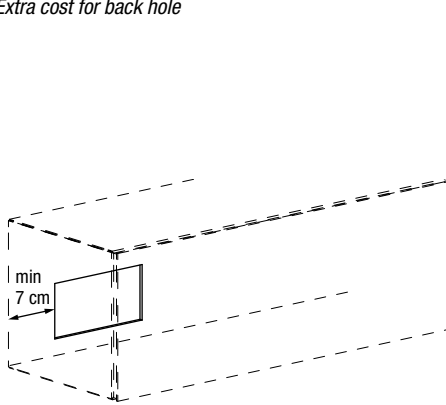
Descrizione//Description	Diametro Diameter		Codice Code	Plastica colore alluminio Aluminium-effect plastic
<b>Passacavi rotondo (foro su top o fianco)</b> <i>Round cableway (hole in top or side)</i> 	Ø 6, 7 (foro//hole Ø 6)		TER052	
<b>Passacavi ovale (foro su top o fianco)</b> <i>Oval cableway (hole in top or side)</i> 	Larghezza Width	Profondità Depth	Codice Code	Plastica colore alluminio Aluminium-effect plastic
	20,5	4,5	TER050	
<b>Passacavi quadrato (foro su top o fianco)</b> <i>Square cableway (hole in top or side)</i> 	Larghezza Width	Profondità Depth	Codice Code	Alluminio Aluminium
	10	10	TER030	
<b>Passacavi rettangolare (foro su top)</b> <i>Rectangular cableway (hole in top)</i> 	Larghezza Width	Profondità Depth	Codice Code	Alluminio Aluminium
	18	5	TER031	
<b>Passacavi rettangolare (foro su top)</b> <i>Rectangular cableway (hole in top)</i> 	Larghezza Width	Profondità Depth	Codice Code	Alluminio Aluminium
	24	10	TER032	
<b>Vaschetta metallica porta ciabatta</b> <i>Metal tray for cables and multiple sockets</i> 	Altezza Height	Profondità Depth	Codice Code	Alluminio Aluminium
	9	16	TER033	
<b>Maggiorazione per foro su schiena</b> <i>Extra cost for back hole</i> 	Codice Code		Maggiorazione Extra Cost	
	RID019			

ATTENZIONE: indicare la posizione del passacavi al momento dell'ordine.  
 IMPORTANT: indicate the position of the cableway when placing the order.

# ILLUMINAZIONE PER CONTENITORI 36E8 E COMPOSIZIONI//STORAGE-UNIT LIGHTING 36E8 AND COMPOSITIONS

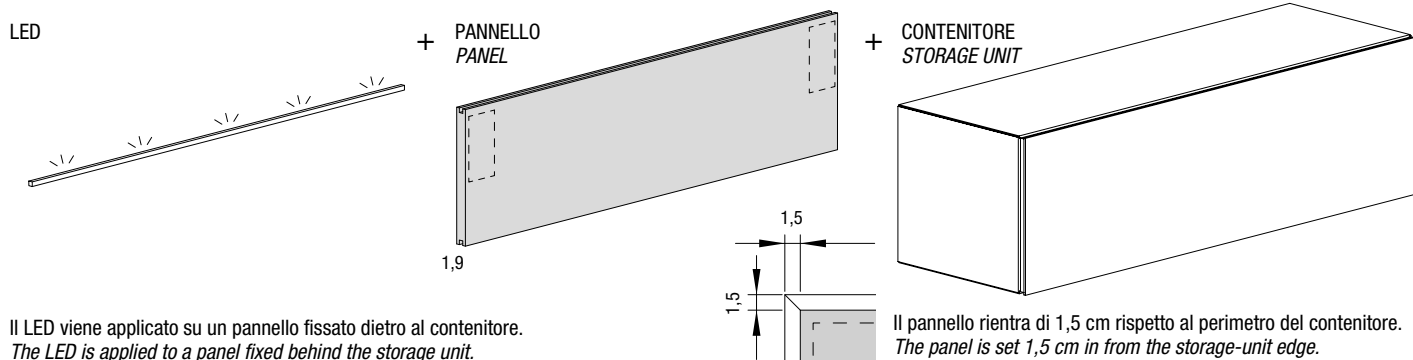

Descrizione/Description	Altezza contenitore Storage-unit height	Larghezza contenitore Storage unit width	Codice Code	Pannello Panel	
<b>Pannello per illuminazione LED per contenitori 36e8 con anta</b> Panel for LED lighting for 36e8 storage units with door  Pannello per illuminazione LED sopra e/o sotto Panel for LED lighting above and/or below  * <b>ATTENZIONE:</b> H 18,4 - 27,6 - 36,8 non disponibili per contenitori P. 51 cm * <b>NOTE:</b> H 18,4 - 27,6 - 36,8 not available for storage units D. 51 cm  Alloggio per alimentatore Power supply housing	18,4 *	36,8	TER7501		
		55,2	TER7502		
		73,6	TER7503		
		92	TER7504		
		110,4	TER7505		
		147,2	TER7507		
		184	TER7508		
		27,6 *	36,8	TER7553	
			55,2	TER7554	
	73,6		TER7555		
	92		TER7556		
	110,4		TER7557		
	147,2		TER7558		
	184		TER7559		
	36,8 *		36,8	TER7509	
			55,2	TER7510	
		73,6	TER7511		
		92	TER7512		
		110,4	TER7513		
		147,2	TER7515		
		184	TER7516		
		55,2	220,8	TER7517	
			36,8	TER7518	
	55,2		TER7519		
	73,6		TER7520		
	92		TER7521		
	110,4		TER7522		
147,2	TER7524				
184	TER7525				
220,8	TER7526				
73,6	36,8	TER7527			
	55,2	TER7528			
	73,6	TER7529			
	92	TER7530			
	110,4	TER7531			
	147,2	TER7533			
	184	TER7534			
	220,8	TER7535			
	92	36,8	TER7536		
55,2		TER7537			
73,6		TER7538			
110,4		36,8	TER7539		
		55,2	TER7540		
		73,6	TER7541		
		110,4	TER7542		
		147,2	36,8	TER7543	
			55,2	TER7544	
	73,6		TER7545		
	184		36,8	TER7546	
			55,2	TER7547	
73,6			TER7548		
36,8			TER7549		
220,8			55,2	TER7550	
			73,6	TER7551	

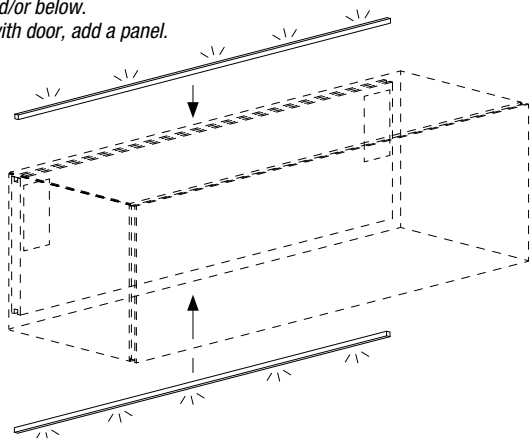
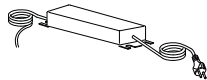

Descrizione//Description	Larghezza Width	Watt	Codice Code	Illuminazione LED LED lighting
<p><b>Illuminazione LED 3.000°K</b>  <b>Applicabile sopra e/o sotto.</b>  <b>Per contenitori 36e8 con anta aggiungere pannello.</b>  <b>Alimentatore non incluso.</b>  <i>LED lighting 3.000°K</i>  <i>Can be applied above and/or below.</i>  <i>For 36e8 storage units with door, add a panel.</i>  <i>Power unit not included.</i></p> 	36,8	4,2	CU1605	
	55,2	6,3	CU1610	
	73,6	8,4	CU1615	
	92	10,5	CU1620	
	110,4	12,6	CU1625	
	128,8	14,7	CU1630	
	147,2	16,8	CU1635	
	165,6	18,9	CU1640	
	184	21	CU1645	
	202,4	23,1	CU1650	
	220,8	25,2	CU1655	
	239,2	27,3	CU1660	
	257,6	29,4	CU1665	
	276	31,5	CU1670	
294,4	33,6	CU1675		
312,8	35,7	CU1680		
<p><b>Alimentatore 24V, 4 uscite</b>                      Prevedere un alimentatore e un punto luce per ogni LED.                      Non sono predisposti passaggi di cavi.  <i>Power unit 24V, 4 outputs</i>  <i>Consider one power unit and one light point for each LED.</i>  <i>Not set up for cables to pass through.</i></p> 	Watt	Codice Code	Alimentatore Power supply	
	30	CU1703		
	100	CU1710		
<p><b>Radiocomando dimmer</b>                      Dimmer remote</p>	24V max 144W	CU1801		

**Contenitori 36e8 affiancati**

Per composizioni con più contenitori prevedere pannelli singoli e barra illuminazione LED unica con un unico alimentatore.  
 Nel caso in cui la larghezza totale superi i 312,8 cm vengono fornite 2 barre illuminazione LED e 2 alimentatori. L'alimentatore viene alloggiato nell'elemento più esterno.  
 Si consiglia di applicare l'illuminazione solo sotto, oppure sotto e sopra, per evitare che l'interruzione tra pannelli sia visibile.

**36e8 storage units side by side**

*For compositions with multiple storage units, consider individual panels and one LED strip light with one power unit.*  
*If the overall width exceeds 312,8 cm, 2 LED strip lights and 2 power units will be supplied. The power unit is housed in the end unit.*  
*We suggest fitting the lighting on the lower part of the unit only, or alternatively on both the upper and lower part to avoid seeing the interruption between panels.*

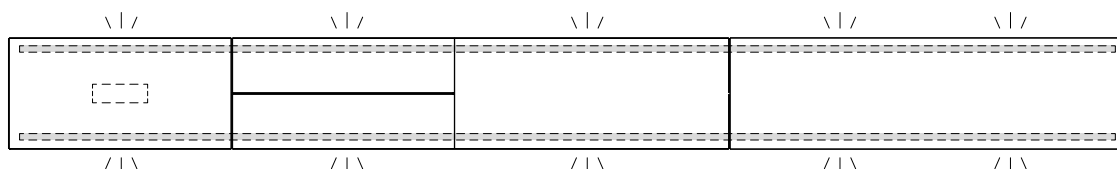

**Contenitori 36e8 affiancati a 36e8 Glass**

È sconsigliato applicare il pannello per illuminazione LED ai contenitori 36e8 per non perdere l'allineamento in profondità.

**36e8 storage units next to 36e8 Glass**

*We do not recommend applying the LED lighting panel to 36e8 storage units as this would misalign the unit depths.*

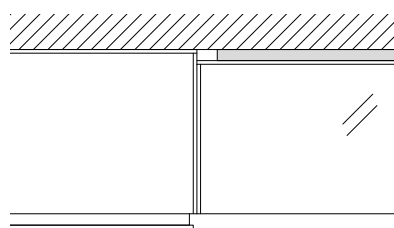

**36e8 Wall panels affiancati**

Due o più 36e8 Wall panels affiancati oppure 36e8 Wall panels affiancati a contenitori 36e8 e/o 36e8 Glass devono prevedere barre illuminazione LED singole e non una barra unica.

**36e8 Wall Panels side by side**

*Two or more 36e8 Wall Panels side by side, or 36e8 Wall Panels next to 36e8 storage units and/or 36e8 Glass must have individual LED strip lights and not one single strip light.*

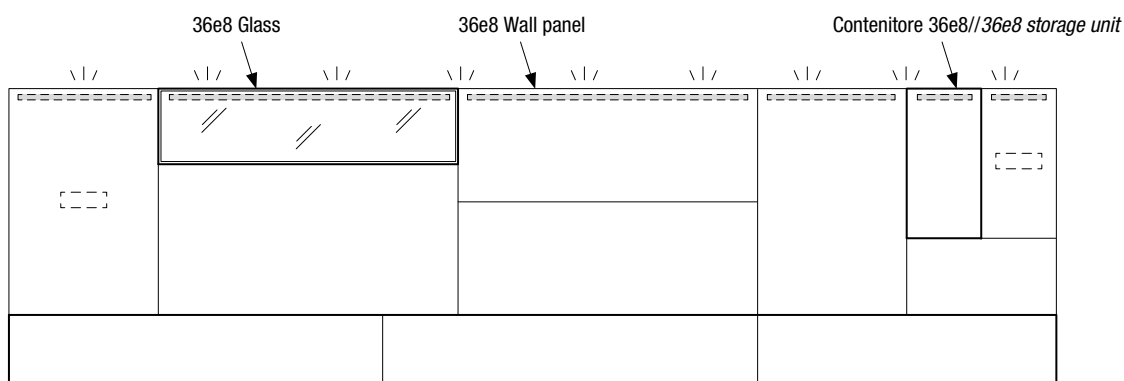

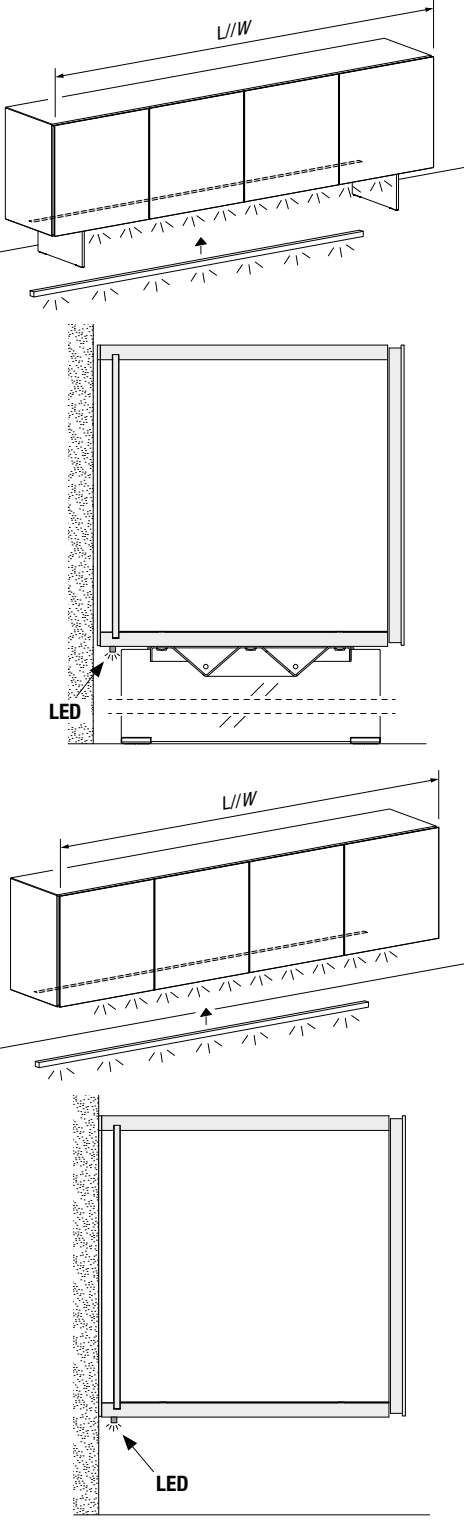
Descrizione//Description	Larghezza Width	Watt	Codice Code	LED
<p><b>Illuminazione LED sottobase</b>                      3000° K, fissaggio con clip, accensione con sensore (incluso). Alimentatore non incluso.  <b>LED lighting under base</b>                      3000° K, clip, control with sensor (included). Power unit not included.</p> 	<p>36,8 73,6 110,4 147,2 184 202,4 220,8 239,2 257,6 276 294,4 312,8</p>	<p>4,2 8,8 13,2 17,7 22,1 24,3 26,5 28,7 30,9 32 35,3 36</p>	<p>D20079 D20078 D20061 D20063 D20065 D20066 D20067 D20068 D20069 D20080 D20070 D20081</p>	
<p><b>Alimentatore 24V, 4 uscite</b>                      Prevedere almeno un punto luce.                      Non sono predisposti passaggi di cavi.  <b>Power unit 24V, 4 outputs</b>                      At least one light required.                      Not set up for cables to pass through.</p>		<p><b>Watt</b>  30 60 W a 110V per mercato USA 60 W with 110V for US market</p>	<p><b>Codice Code</b>  D20008</p>	<p><b>Alimentatore Power supply</b></p>

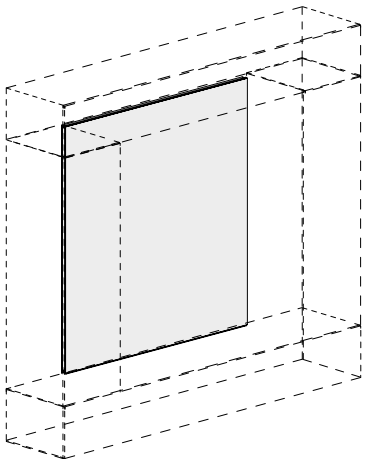
Descrizione//Description	Larghezza Width	Altezza Height	Codice Code	Laccato Lacquered	Vetro lucido o specchio* Polished glass or mirror*	Vetro opaco Matt glass	XGlass lucido o opaco polished or matt	Rovere Gentle Gentle Oak
<p><b>Schienale per vani interni</b> <i>Back for closed niches</i></p>  <p>Bordi con guarnizione e retro non finiti Schienale laccato sp. 1,9 cm Schienale Rovere Gentle sp. 1,9 cm Schienale vetro/specchio sp. 2 cm <i>Edging with seal without finish Lacquered back thickness 1.9 cm Gentle oak back, 1,9 cm thick Glass/mirror back, 2 cm thick</i></p> <p>Taglio in larghezza e altezza senza sovrapprezzo. <i>Cut in width and height with no surcharge.</i></p>	36,8	36,8	SBP003					
		73,6	SBP007					
		110,4	SBP011					
		184	SBP018					
		257,6	SBP025					
	73,6	36,8	SBP103					
		73,6	SBP107					
		110,4	SBP111					
		184	SBP118					
		257,6	SBP125					
	110,4	36,8	SBP203					
		73,6	SBP207					
		110,4	SBP211					
		184	SBP218					
	147,2	220,8	SBP222					
		36,8	SBP303					
		73,6	SBP307					
	184	110,4	SBP311					
		36,8	SBP403					
		73,6	SBP407					
	220,8	110,4	SBP411					
		36,8	SBP503					
73,6		SBP507						
		110,4	SBP511					

\*\* Con specchio specificare colore pannello  
\*\* For the mirror finish specify the colour of the panel

\* Specchio: disponibile nelle finiture naturale, fumè grigio o fumè bronzo.  
\* Mirror: available in the Naturale, Smoked grey or Smoked bronze finishes.

**INFORMAZIONI GENERALI  
GENERAL INFORMATION**

Tutti i pannelli di particelle di legno nobilitati con carte melaminiche sono a bassa emissione di formaldeide e certificati Carb e TSCA title VI con bordi in ABS in tinta.  
Per la laccatura di pannelli e vetri vengono utilizzate solo vernici all'acqua.  
*All MDF panels are low formaldehyde CARB and TSCA Title VI certified, faced with melamine and with ABS edges in a matching colour.  
Only water-based paints are used on the panels and glass.*

**STRUTTURA LACCATA  
LACQUERED STRUCTURE**

Pannello nobilitato spessore 1,9 cm, laccato con vernici all'acqua, con giunzione a 45° mediante un giunto di alluminio anodizzato.  
*Melamine panel 1,9 cm thick, lacquered with water-based paints, with a 45° join using an anodised aluminium joint.*

**STRUTTURA ROVERE GENTLE  
GENTLE OAK STRUCTURE**

Pannello di particelle di legno certificato Carb e TSCA title VI, rivestito con impiallacciatura di rovere, spessore totale 1,9 cm. Bordi in rovere su supporto in ABS, con giunzione a 45° mediante un giunto di alluminio anodizzato.  
*MDF panel, CARB and TSCA Title VI certified, faced in oak veneer, total thickness 1,9 cm, Edges in oak on ABS support, with a 45° join using an anodised aluminium joint.*

**SCHIENA  
BACK**

Pannello nobilitato spessore 0,8 cm laccato con vernici all'acqua.  
*Melamine panel 0,8 cm thick, lacquered with water-based paints.*

**FRONTALI  
FRONTS**

Laccato: fibra di legno a media densità MDF spessore 1,9 cm, laccato su fondo poliestere.

Vetro lucido o vetro opaco o specchio: vetro temperato spessore 0,4 cm, acidato per la versione vetro opaco, laccato con vernici all'acqua, accoppiato ad un pannello nobilitato spessore 1,6 cm, laccato con vernici all'acqua.

XGlass: vetro temperato spessore 0,4 cm finito con una verniciatura acrilica UV e retro-verniciatura all'acqua.  
Pannello nobilitato spessore 1,9 cm.

Wildwood: pannello di legno listellare con uno strato di rovere spessore 0,4 cm, rivestito internamente con impiallacciatura di rovere, spessore totale 1,8 cm.

*Lacquered: MDF 1,9 cm thick, lacquered on polyester base.*

*Polished glass or matt glass or mirror: tempered glass 0,4 cm thick, etched for the matt glass version, lacquered with water-based paints, paired with a melamine panel 1,6 cm thick, lacquered with water-based paints.*

*XGlass: tempered glass 0,4 cm thick, finished with a UV acrylic paint and painted on the back with a water-based paint.  
Melamine panel 1,9 cm thick.*

*Wildwood: blockboard wood panel with a layer of oak 0,4 cm thick, internally faced with oak veneer, total thickness 1,8 cm.*

**RIPIANI VETRO  
GLASS SHELVES**

Vetro trasparente temperato spessore 0,8 cm per contenitori con anta.  
Vetro trasparente extrachiaro temperato sp. 0,8 cm per contenitori a giorno.  
*Clear tempered glass 0,8 cm thick for storage units with door.  
Shelves made of extra-clear tempered glass, 0,8 cm thick for open compartment storage units.*

**CASSETTI INTERNI  
INTERNAL DRAWERS**

Pannello nobilitato spessore: 1,6 cm, fondo spessore 0,8 cm.  
*Melamine panel 1,6 cm thick, bottom 0,8 cm thick.*

**36e8 GLASS**

Fianchi, coperchio e fondo: vetro extrachiaro o vetro fumé temperato spessore 0,8 cm, uniti a 45°.  
Schiena: vetro extrachiaro temperato spessore 0,6.  
Tutti le parti sono incollate con incollaggio UV.  
Schiena interna vetro lucido, vetro opaco, XGlass o specchio spessore 0,4 cm incollata.  
Pannello nobilitato spessore 1,9 cm con attaccaglie regolabili in 3 direzioni.  
*Sides, top and bottom: tempered Extrachiaro glass or smoked glass, 0,8 cm thick, joined at 45°.  
Back: Extrachiaro tempered glass 0,6 thick.  
All parts are glued with UV gluing.  
Internal back panel in polished glass, matt glass, XGlass or mirror 0,4 cm thick, glued.  
Melamine panel 1,9 cm thick with adjustable hangers in 3 directions.*

**PORTATA  
CAPACITY**

**Elementi sospesi o a terra  
Wall or floor units**

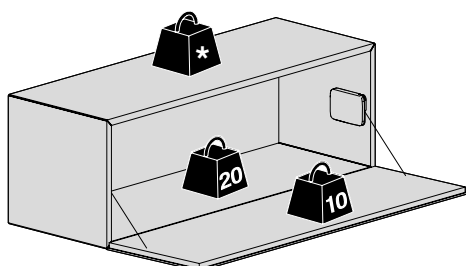

	P 27	P 40,6	P 51
* Senza barra TV carico distribuito <i>Without TV rack, distributed load</i>	20	20	25
* Con barra TV carico concentrato <i>With TV rack, concentrated load</i>	25	25	30

**Portata interna cassetti: 15 kg  
Drawer capacity: 15 kg**

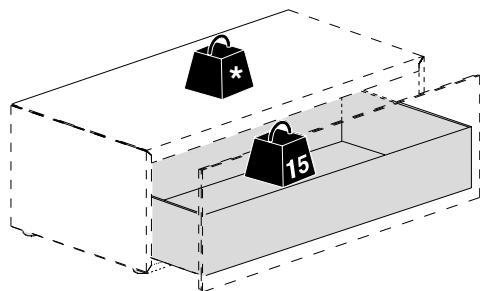

	P 40,6	P 51
* Senza barra TV carico distribuito <i>Without TV rack, distributed load</i>	20	25
* Con barra TV carico concentrato <i>With TV rack, concentrated load</i>	25	30

**Portata ripiani (vetro): 10 kg  
Shelf capacity (glass): 10 kg**

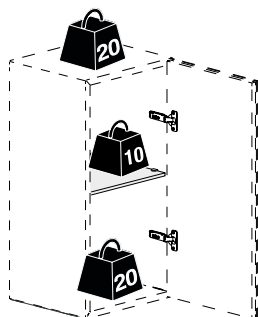

**36e8 Glass\_storage**

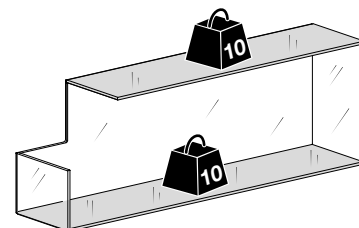
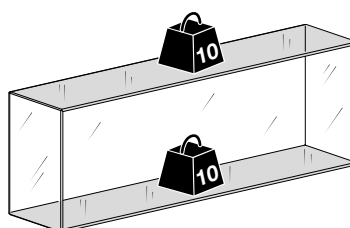

## CONSIGLI DI PROGETTAZIONE//PLANNING SUGGESTIONS











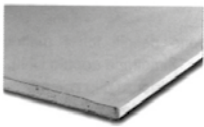

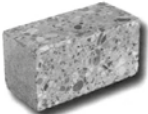

**ATTENZIONE!** Alcune tipologie di pareti non sono adatte al fissaggio di prodotti di questo tipo, ma necessitano dell'aggiunta di rinforzi interni in corrispondenza dei punti di fissaggio. La verifica dell'idoneità del muro e dei tasselli resta a carico del progettista, si invita ad effettuare sempre tale verifica preventivamente. Lago S.p.A. declina ogni responsabilità per danni causati a cose o persone che derivano da problemi di tenuta del muro.

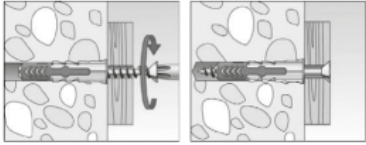
**WARNING!** Some walls are not suitable for mounting products like this to and require internal reinforcement at the points where the product is attached. The architect/designer is responsible for checking the suitability of the wall and plugs and we invite you to always check this first. Lago S.p.A. declines any liability for damage caused to people or property deriving from problems with the strength of the wall.

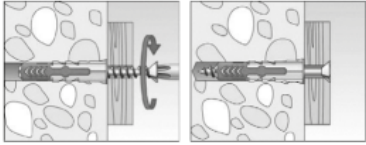
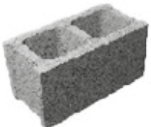
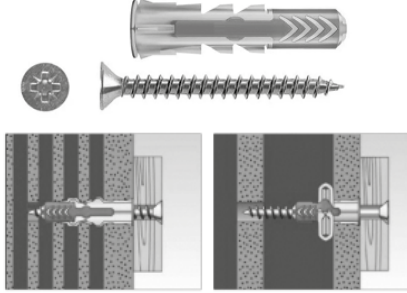
### La qualità del fissaggio a parete dipende da://The quality of the fixing to wall depends on:

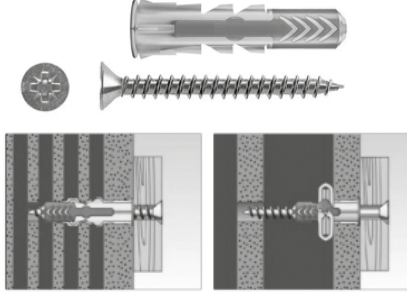
FERRAMENTA E STRUTTURA MOBILE// <i>HARDWARE AND FURNITURE'S STRUCTURE</i>	▶	Garanzia LAGO// <i>LAGO guarantee</i>
TASSELLI E VITI// <i>RAWLPLUGS AND SCREWS</i>	▶	Responsabilità del progettista e del montatore// <i>Project architect's and assembler's responsibility</i>
PARETE// <i>WALL</i>	▶	Responsabilità del progettista e del montatore// <i>Project architect's and assembler's responsibility</i>
QUALITÀ MONTAGGIO// <i>ASSEMBLY QUALITY</i>	▶	Responsabilità del montatore// <i>Assembler's responsibility</i>

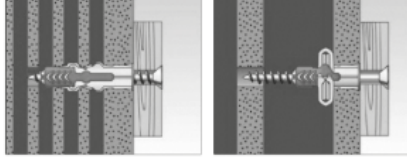
### Alcuni esempi di pareti e consuetudine di fissaggio//Examples of walls and types of fixing

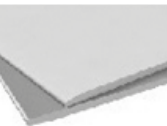
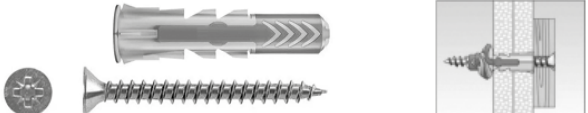
TIPO DI PARETE// <i>WALL STRUCTURE</i>	TIPO DI FISSAGGIO// <i>FIXING TYPE</i>
<b>CARTONGESSO SINGOLA LASTRA</b> <b>SINGLE PLASTERBOARD SHEET</b> Pannelli in gesso rivestiti da fogli di cartone. <i>Plaster panels covered in cartboards.</i> 	 <b>NON REALIZZABILE</b> <b>NOT FEASIBLE</b>
<b>MATTONI IN LATERIZIO FORATO Sp. 8 cm</b> <b>HOLLOW BRICK 8 cm thick</b> È principalmente in argilla con oltre il 55% di parti vuote, sp. 8 cm. <i>Made mainly of clay with over 55% hollow, 8 cm thick.</i> 	 <b>NON REALIZZABILE</b> <b>NOT FEASIBLE</b>
<b>CALCESTRUZZO//CONCRETE</b> Composto di cemento, acqua e inerti privo di vuoti. <i>Made from cement, water and aggregates. There are no holes.</i> 	 
<b>MATTONI PIENO//SOLID BRICK</b> È principalmente in argilla fino al 15% di parti vuote. <i>Made from clay volume of perforation: up to 15% of the total volume.</i> 	
<b>CALCESTRUZZO AREATO AUTOCLAVATO ≥ PB4, PP2 (G4)</b> <b>AUTOCLAVED AERATED CONCRETE ≥ PB4, PP2 (G4)</b> Composto di cemento, acqua e inerti con aperture per il passaggio dell'aria. <i>Composed of cement, water and aggregates with air vents.</i> 	
<b>MATTONI FORATI//HOLLOW BRICK</b> È principalmente in argilla con oltre il 55% di parti vuote, sp. 8 cm. <i>Made mainly of clay with over 55% hollow, 8 cm thick.</i> 	
<b>MATTONI SEMIPIENO (DOPPIO UNI 19) IN LATERIZIO</b> <b>PERFORATED BRICK (DOUBLE UNI 19)</b> È principalmente in argilla con oltre il 55% di parti vuote, sp. 8 cm. <i>Made mainly of clay with over 55% hollow, 8 cm thick.</i> 	
<b>BLOCCO FORATO POROTON//HOLLOW POROTON BLOCK</b> Impasto di argilla alleggerito da polistirolo espanso fino a 45% di parti vuote. <i>Mix of clay and expanded polystyrene volume of perforation: up to 45% of the total volume.</i> 	
<b>CARTONGESSO SOLO DOPPIA LASTRA</b> <b>DOUBLE PLASTERBOARD SHEET ONLY</b> Doppio strato di pannelli in gesso rivestiti da fogli di cartone. <i>Double layer of gypsum boards faced with sheets of paper.</i> 	

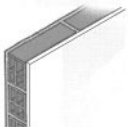
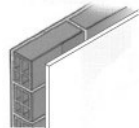
TIPO DI PARETE//WALL STRUCTURE	TIPO DI FISSAGGIO//FIXING TYPE
<p><b>PARETE PORTANTE RIVESTITA IN CARTONGESSO.</b>  <b>LOAD-BEARING WALL COVERED IN PLASTERBOARD.</b></p> 	<p>Considerare la parete portante tra i casi esposti sopra.  <i>List the load-bearing wall among the above-mentioned cases.</i></p>
<p><b>PARETE PORTANTE RIVESTITA IN CARTONGESSO CON INTERCAPEDINE.</b>  <b>LOAD-BEARING WALL COVERED IN PLASTERBOARD WITH CAVITY.</b></p> 	<p>Può risultare utile interporre un materiale tra i tasselli inseriti nel muro portante ed il mobile.  <i>It might be useful to interpose a material among the fittings inserted between the load-bearing wall and the piece of furniture</i></p>

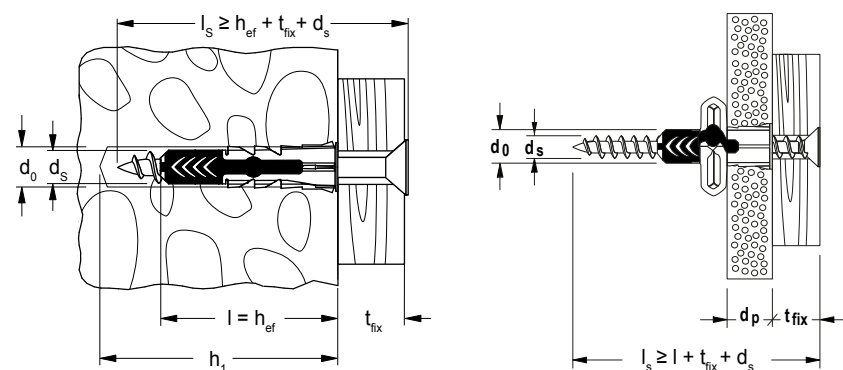

LEGENDA//KEY	
l <sub>s</sub>	▶ lunghezza vite Screw length
d <sub>s</sub>	▶ diametro filetto della vite Screw thread diameter
l = h <sub>ef</sub>	▶ lunghezza tassello Plug length
h <sub>1</sub>	▶ profondità foro Hole depth
t <sub>fix</sub>	▶ spessore da fissare Thickness to be fixed

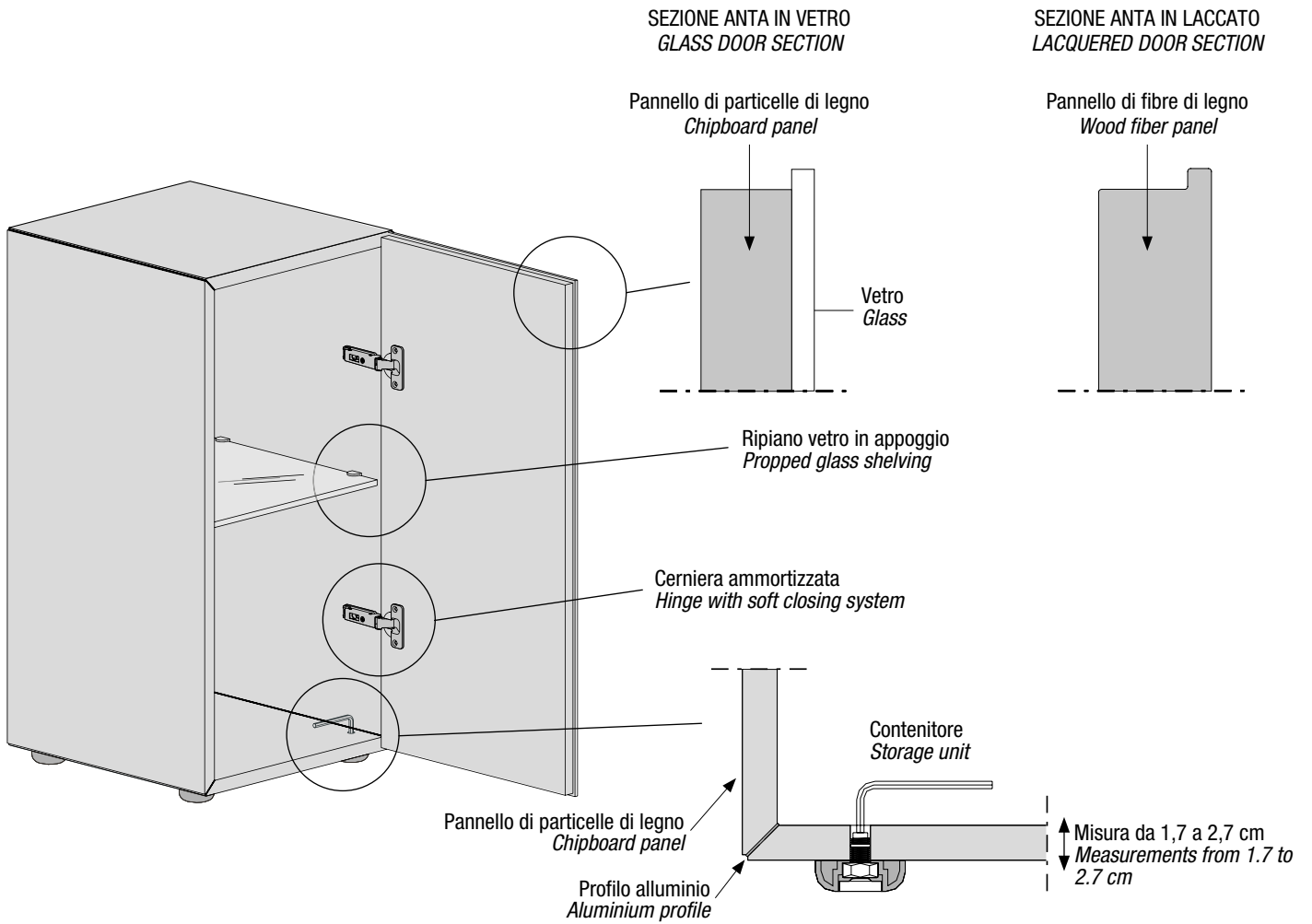

**ESEMPIO APERTURA ANTE E CASSETTI//DOORS AND DRAWERS OPENING - EXAMPLE**

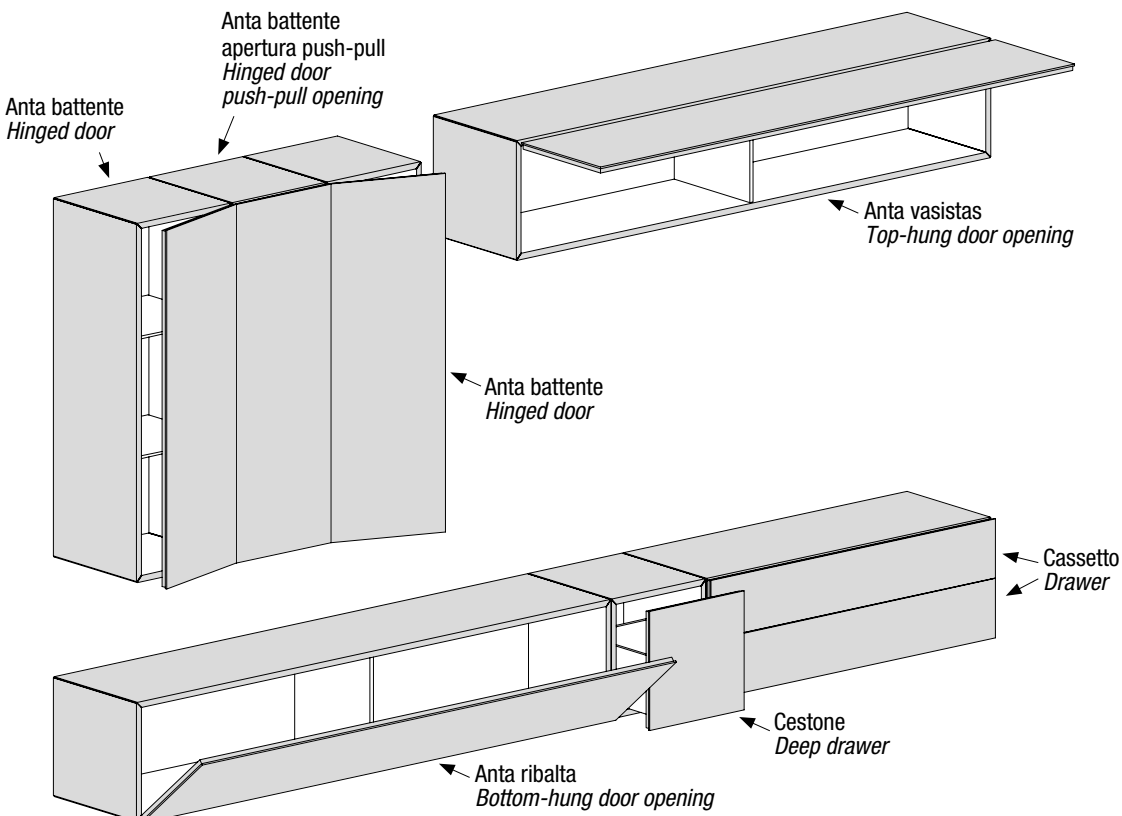



## FISSAGGIO CONTENITORE A MURO//ATTACHING STORAGE UNIT TO THE WALL

P. 27-40,6//P. 27-40,6

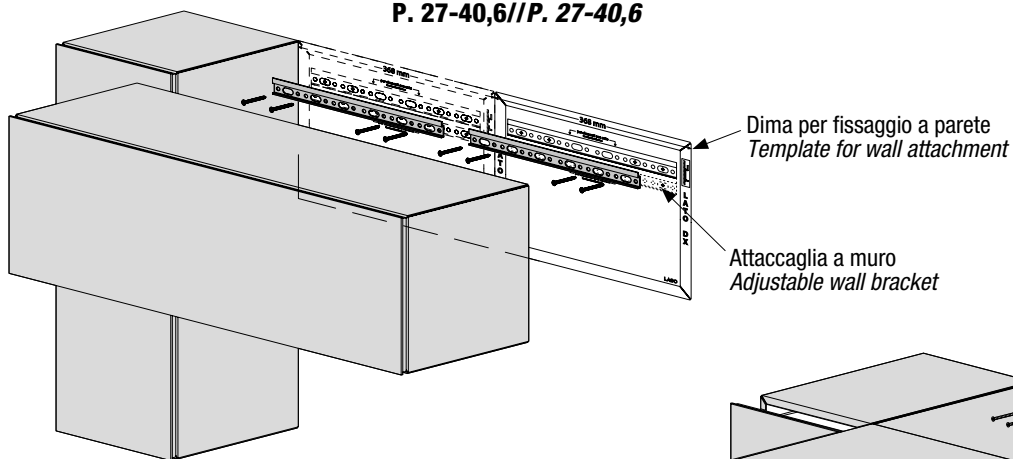

ATTENZIONE: Per pareti in cartongesso su richiesta viene fornita un'attaccaglia a muro più lunga per aumentare i punti di fissaggio.  
CAUTION: Plasterboard walls are provided on request with a longer wall bracket to increase the fastening points.

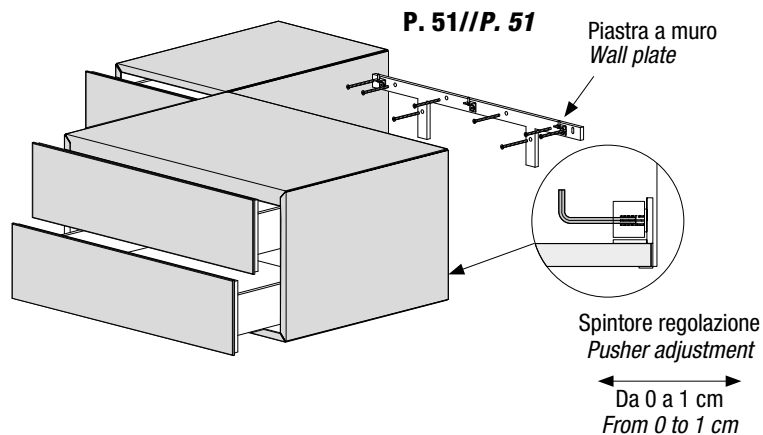

## GIUNZIONE TRA CONTENITORI//STORAGE UNIT FIXING SYSTEM

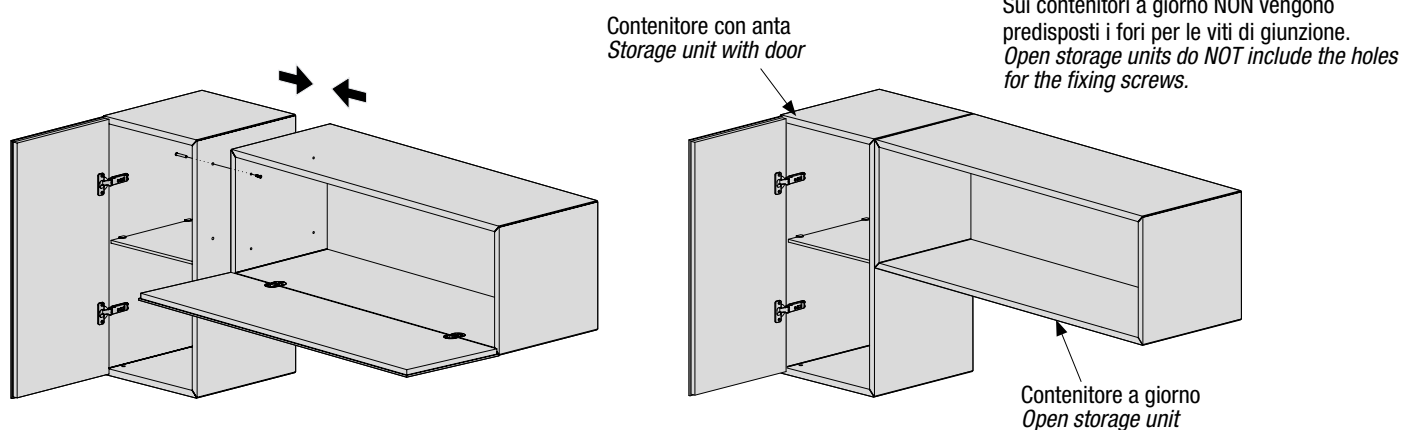

## GIUNZIONE CONTENITORI ANGOLARI//FIXING CORNER CONTAINERS

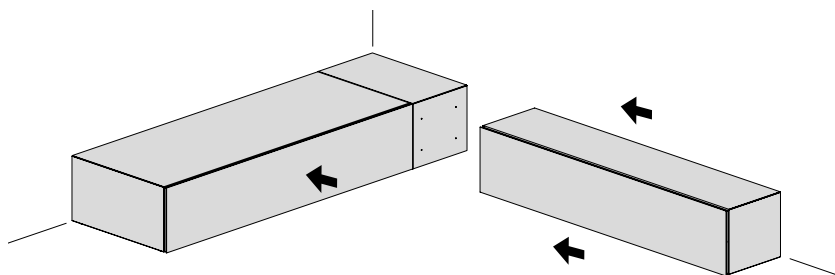

## SOVRAPPOSIZIONE CONTENITORI//OVERLAPPING STORAGE UNITS

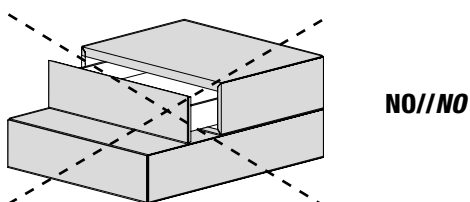

Non sovrapporre contenitori a cassetti con profondità minore.  
Do not place storage units with drawers above deeper storage units.

# P. 40,6 SPAZI UTILI INTERNI SU CASSETTIERE//D. 40.6 USEFUL INTERNAL SPACES-DRAWER UNITS

Sezioni//Sections

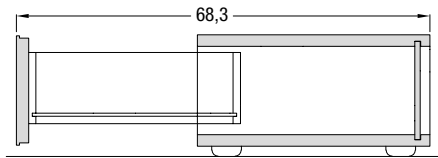

1 cassetto  
1 drawer

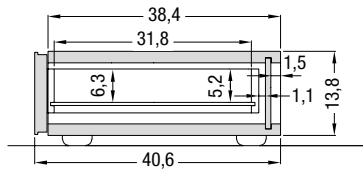

2 cassetti  
2 drawers

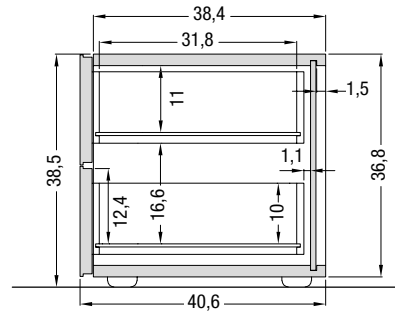

1 cassetto  
1 drawer

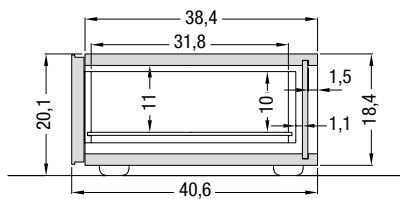

1 cestone  
1 deep drawer

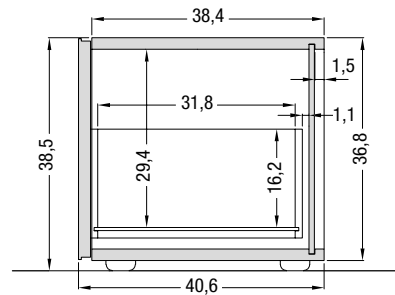

1 cestone  
1 deep drawer

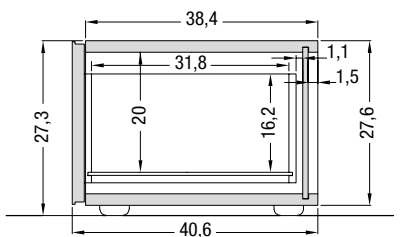

1 cassetto + vano  
a giorno  
1 drawer + open  
compartment

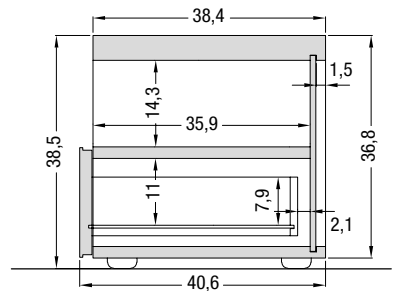

## LARGHEZZA UTILE INTERNA//USABLE INTERNAL WIDTH

LARGHEZZA WIDTH	1 CASSETTO 1 DRAWER	2 CASSETTI 2 DRAWERS	1 CESTONE 1 DEEP DRAWER	1 CASSETTO + VANO A GIORNO 1 DRAWER + OPEN COMPARTMENT
36,8	28,8	28,8	28,8	28,8
73,6	65,6	65,6	65,6	65,6
110,4	28,8 - 65,6	102,4	102,4	102,4
147,2	65,6 - 65,6	65,6 - 65,6	65,6 - 65,6	65,6 - 65,6
184	65,6 - 28,8 - 65,6	65,6 - 102,4	65,6 - 102,4	-

# P. 51 SPAZI UTILI INTERNI SU CASSETTIERE//D. 51.0 USEFUL INTERNAL SPACES-DRAWER UNITS

Sezioni//Sections

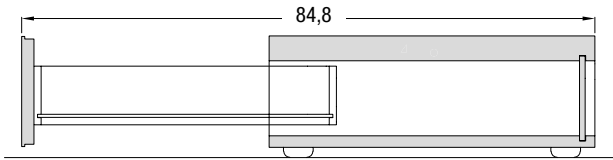

1 cassetto  
1 drawer

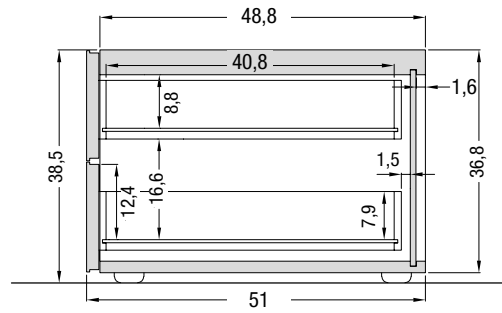
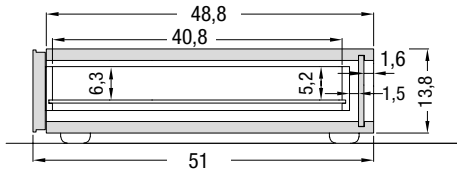

2 cassetti  
2 drawers

1 cassetto  
1 drawer

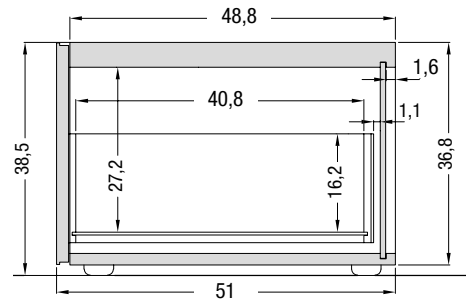
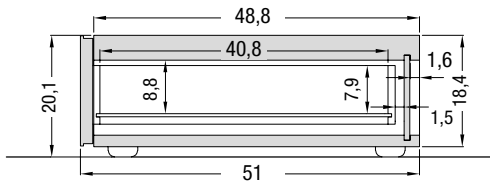

1 cestone  
1 deep drawer

1 cestone  
1 deep drawer

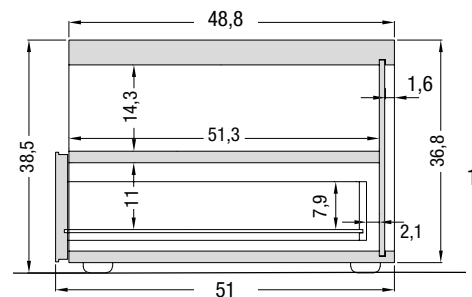
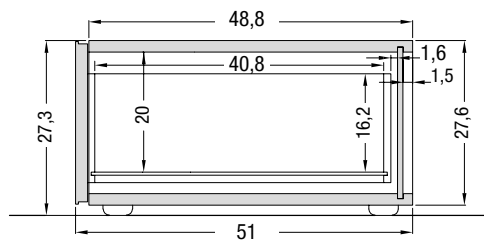

1 cassetto + vano  
a giorno  
1 drawer + open  
compartment

## LARGHEZZA UTILE INTERNA//USABLE INTERNAL WIDTH

LARGHEZZA WIDTH	1 CASSETTO 1 DRAWER	2 CASSETTI 2 DRAWERS	1 CESTONE 1 DEEP DRAWER	1 CASSETTO + VANO A GIORNO 1 DRAWER + OPEN COMPARTMENT
36,8	28,8	28,8	28,8	28,8
73,6	65,6	65,6	65,6	65,6
110,4	28,8 - 65,6	102,4	102,4	102,4
147,2	65,6 - 65,6	65,6 - 65,6	65,6 - 65,6	65,6 - 65,6
184	65,6 - 28,8 - 65,6	65,6 - 102,4	65,6 - 102,4	65,6 - 102,4

**ANTA FISSA PER ELEMENTO BIFACCIALE//FIXED DOOR FOR DOUBLE-SIDED UNIT**

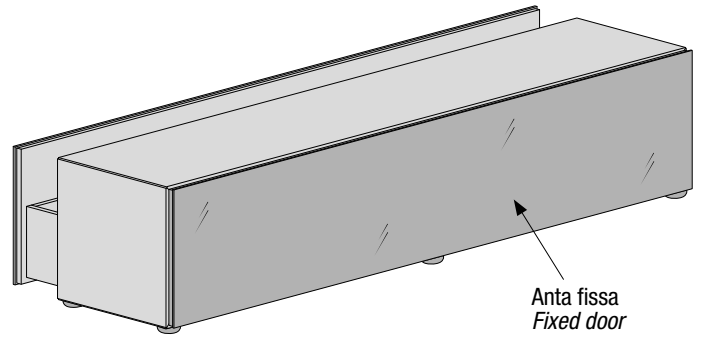
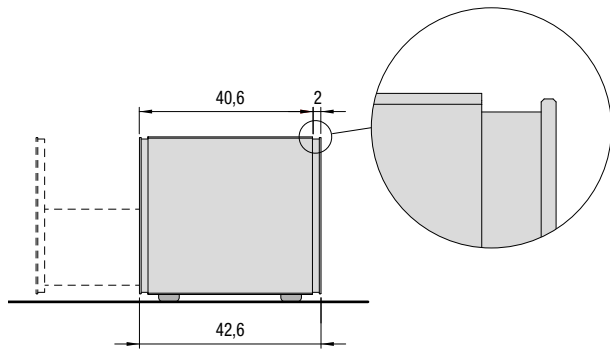

**PANNELLO PER FINITURA RETRO//BACK FINISH PANEL**

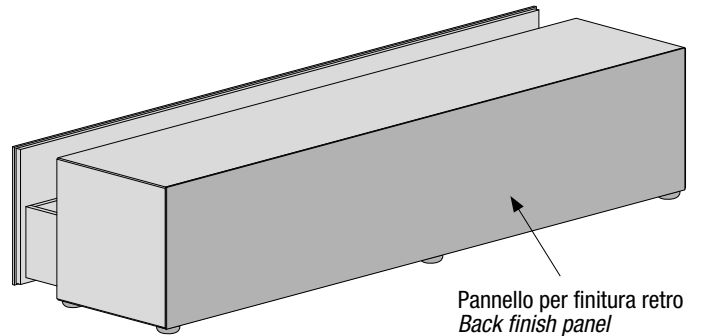
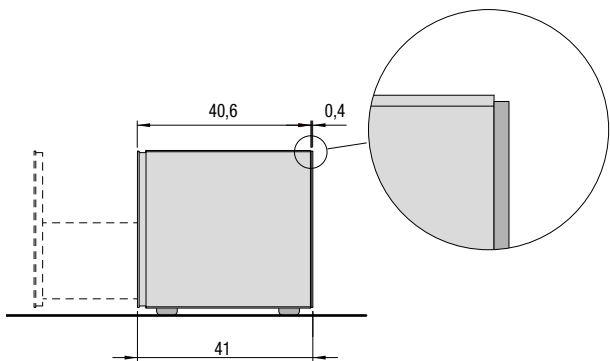

**SOSTEGNI IN VETRO PER CONTENITORE//GLASS SUPPORTS FOR STORAGE UNITS**

ATTENZIONE: tra i due supporti larghezza massima 73,6 cm//IMPORTANT: maximum width between the two supports 73,6 cm

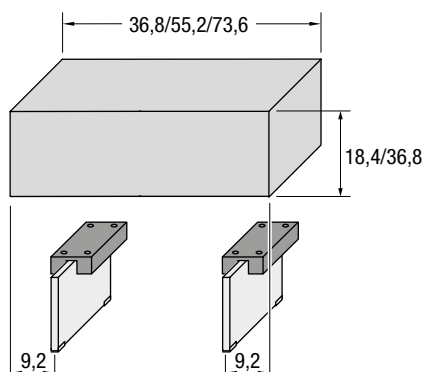
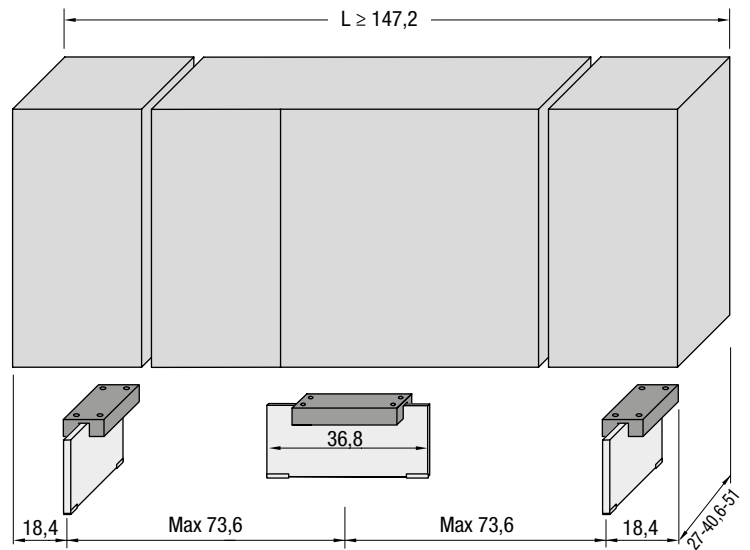
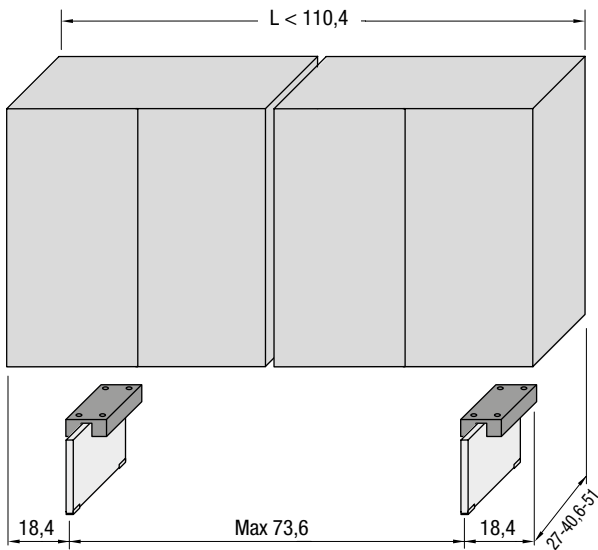

## RIPETITORE IR//IR REPEATER

Il ricevitore e il ripetitore IR (infrarossi) permettono il funzionamento degli apparecchi elettronici (lettore dvd, decoder, impianto hi fi) senza dover tenere aperta l'anta del contenitore.  
 The IR (infrared) receiver and repeater allow the operation of electronic equipment (DVD player, decoder, hi fi) without having to hold the door of the storage unit open.

### Ripetitore IR con supporto in appoggio su top IR repeater with support resting on top

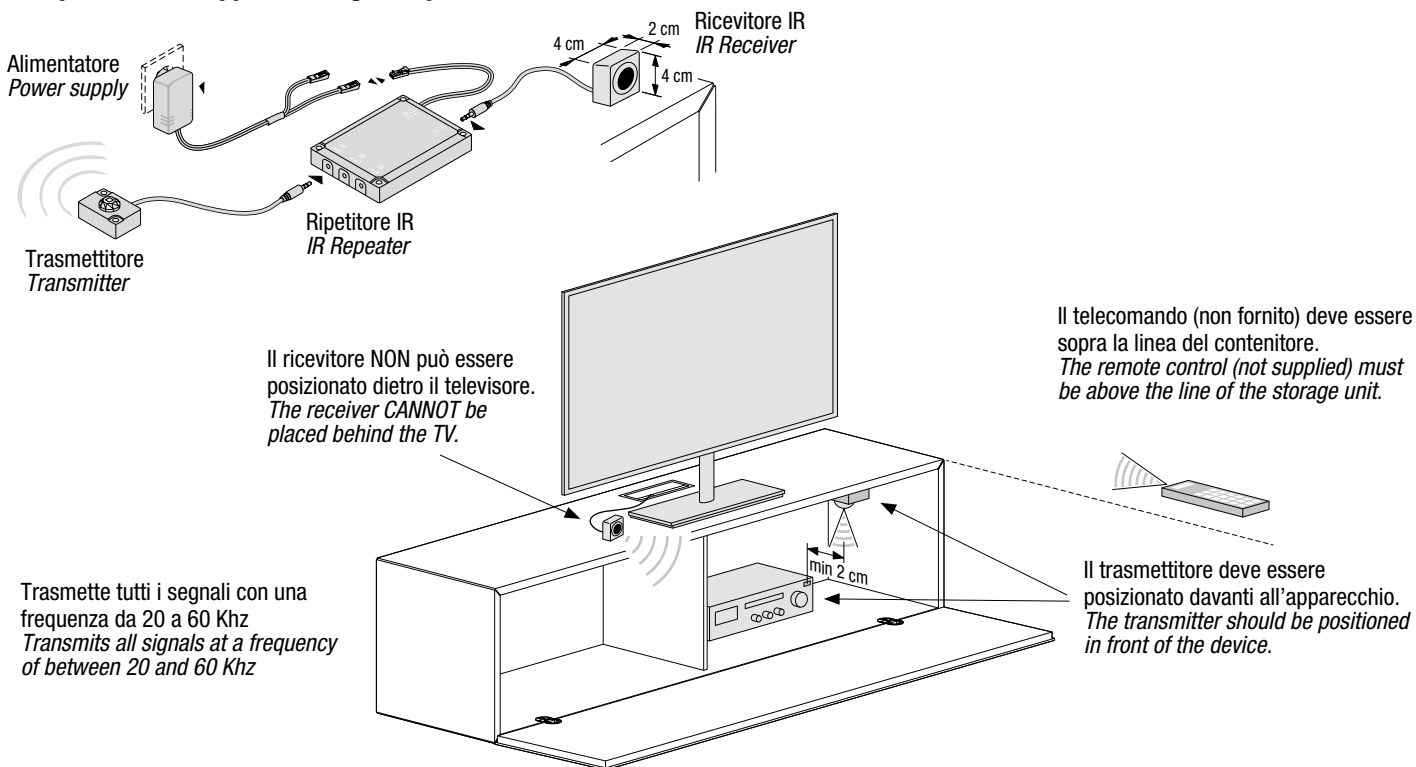

### Ripetitore IR da incassare sul top IR repeater to be recessed into top

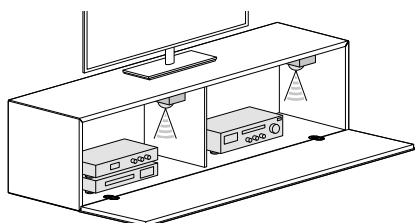
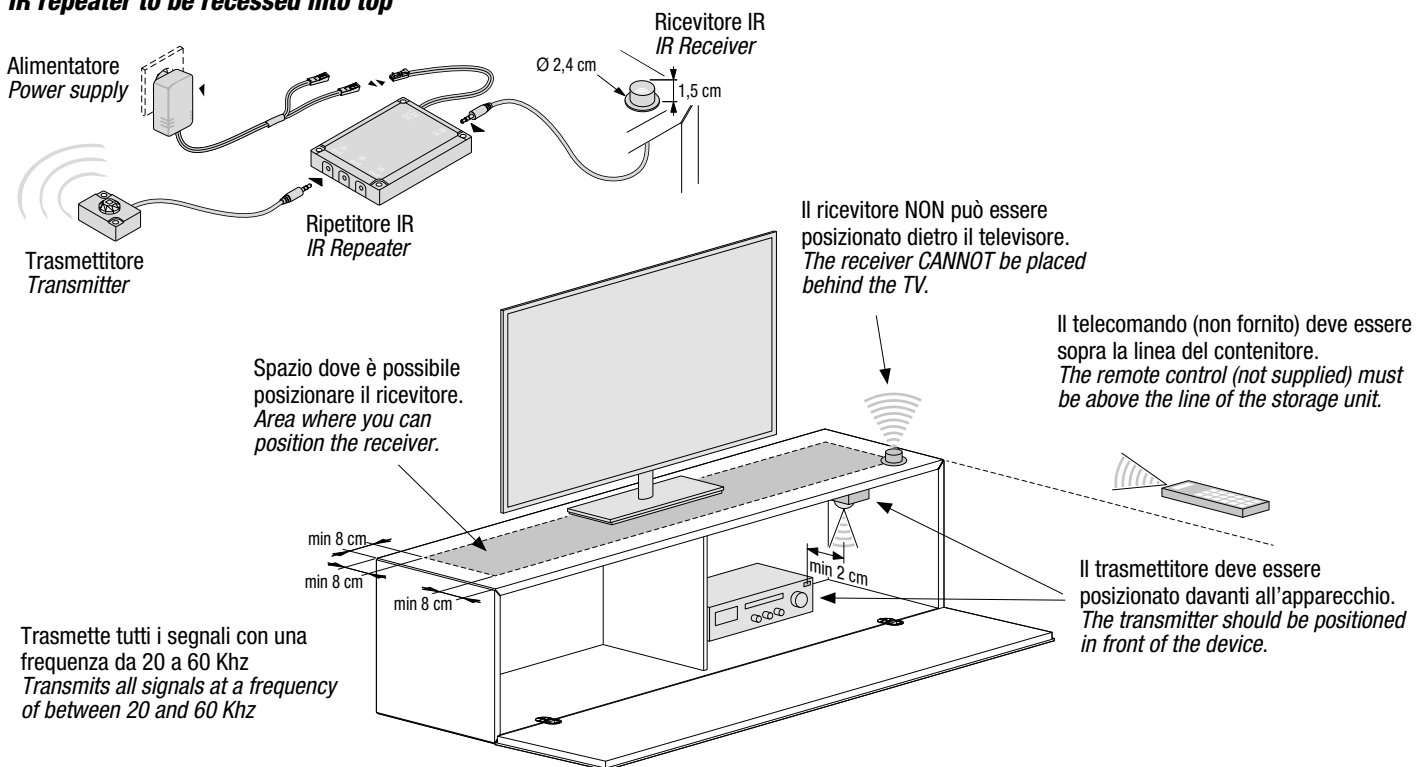

È possibile farlo funzionare anche su due vani con un trasmettitore aggiuntivo da acquistare a parte.  
 Can also be made to work on two compartments using an additional transmitter to be purchased separately.

In alcune composizioni l'apertura standard a tirare non è accessibile. In questi casi è possibile richiedere il meccanismo di apertura "push-pull".  
*For some compositions, the standard pull opening is not accessible. In such cases, it is possible to request the "push-pull" opening mechanism.*

**Cassetti o cestoni tra altri contenitori**  
***Drawers or deep drawers among other storage units***

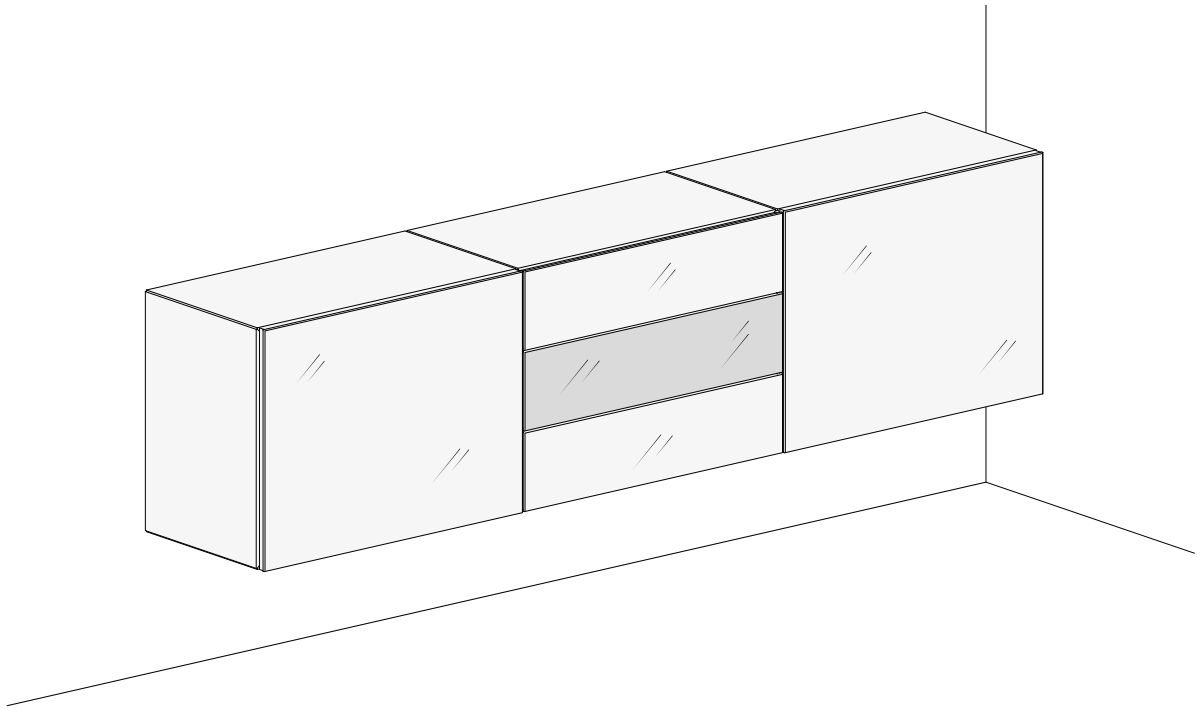

**Cassetti o cestoni in appoggio a terra con top**  
***Drawers or deep drawers resting on the floor with top***

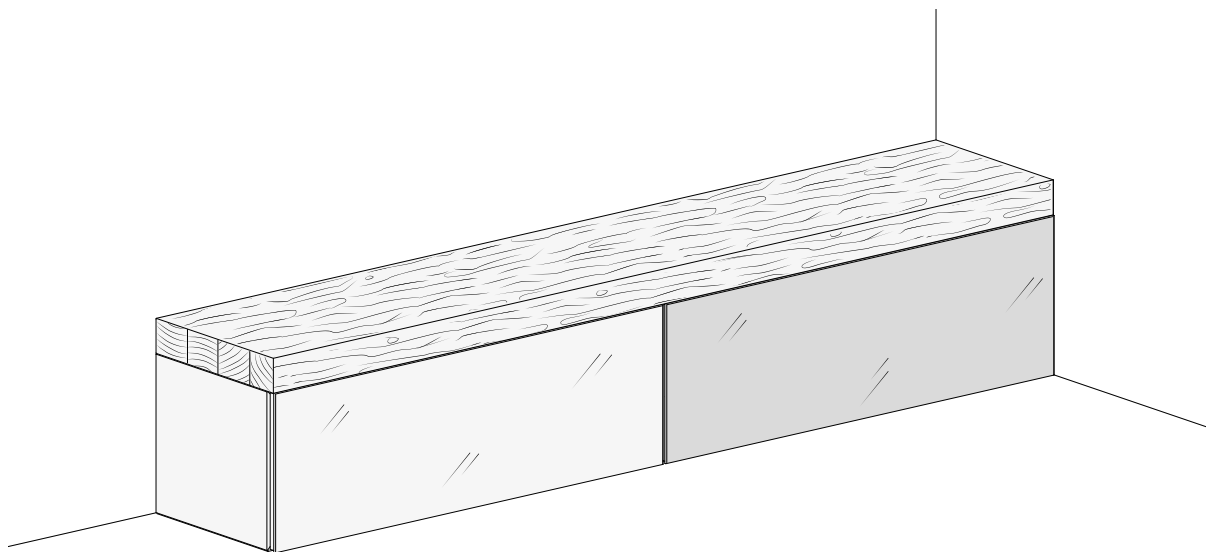

## Funzionamento Operation

⚠ I contenitori affiancati a cassetti o cestoni push-pull dovranno avere a loro volta l'apertura push-pull per avere tutti i frontali allineati tra loro.  
*The storage units paired with push-pull drawers or deep drawers must have a push-pull opening as well, for the alignment of all fronts.*

⚠ Attenzione: non è possibile l'allineamento tra cassetti/cestoni push pull e anta ribalta push pull.  
*Warning: it is not possible to line up push-pull opening drawers/deep drawers with a push-pull opening flap down door.*

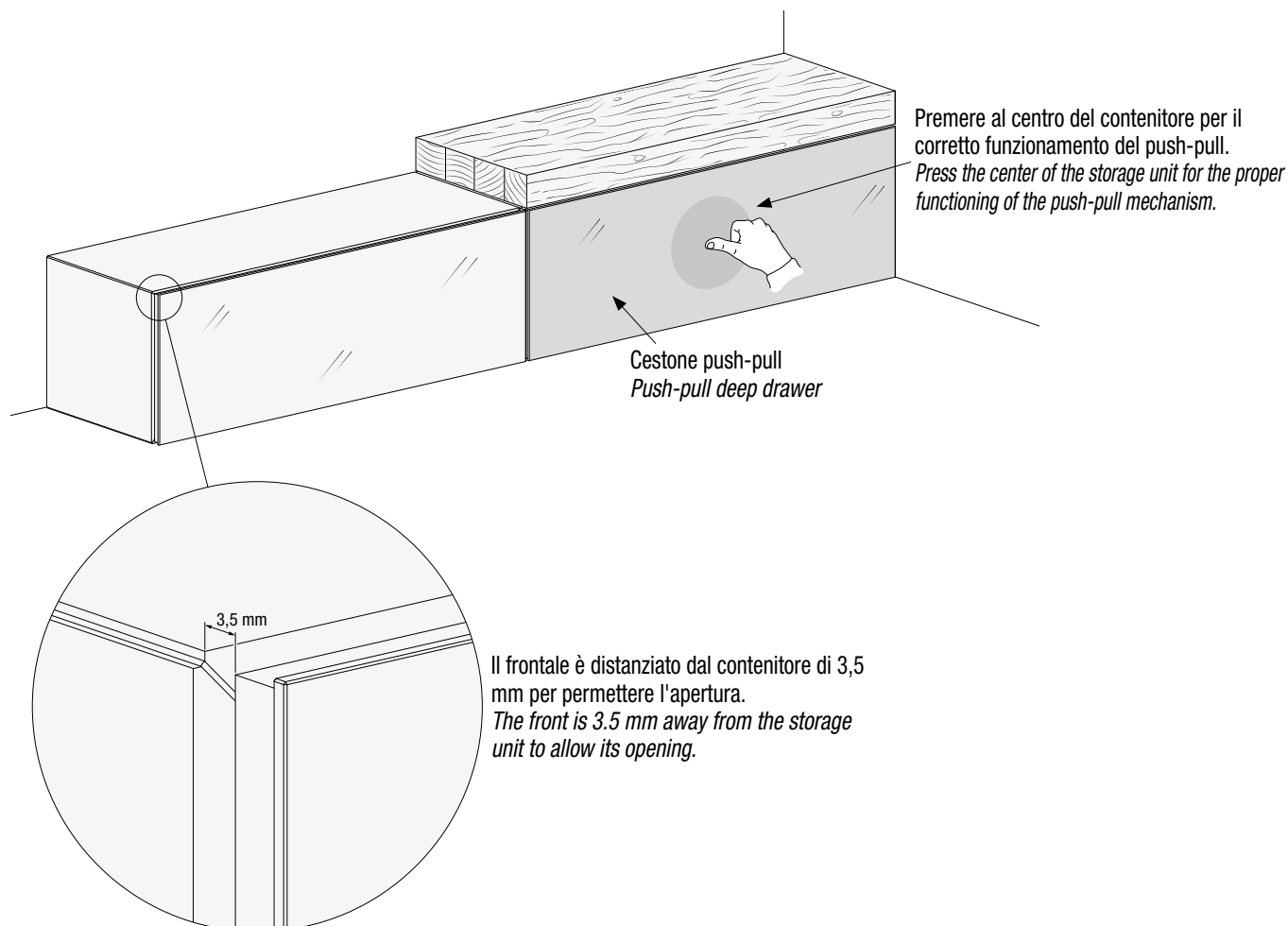

**Cestone L 110,4 H 36,8 P 40,6/51 cm**  
**Deep drawer W 110,4 H 36,8 D 40,6/51 cm**

Solo nei cestoni H 36,8 L 110,4 viene aggiunto un divisorio  
*A partition is added only to H 36.8 W 110.4 deep drawers*

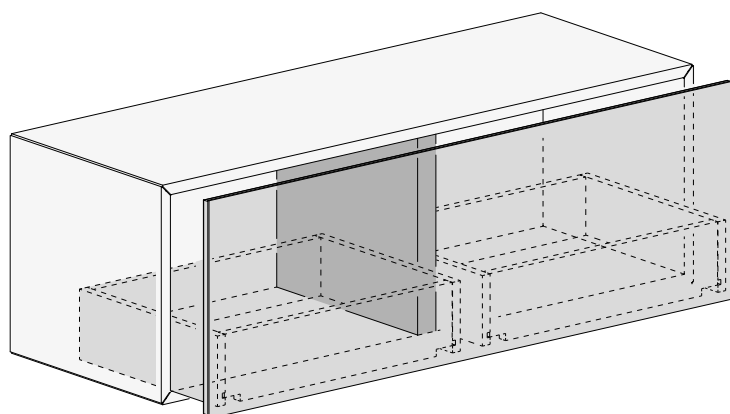

**Schienale laccato (strutturale)//Lacquered back (structural)**

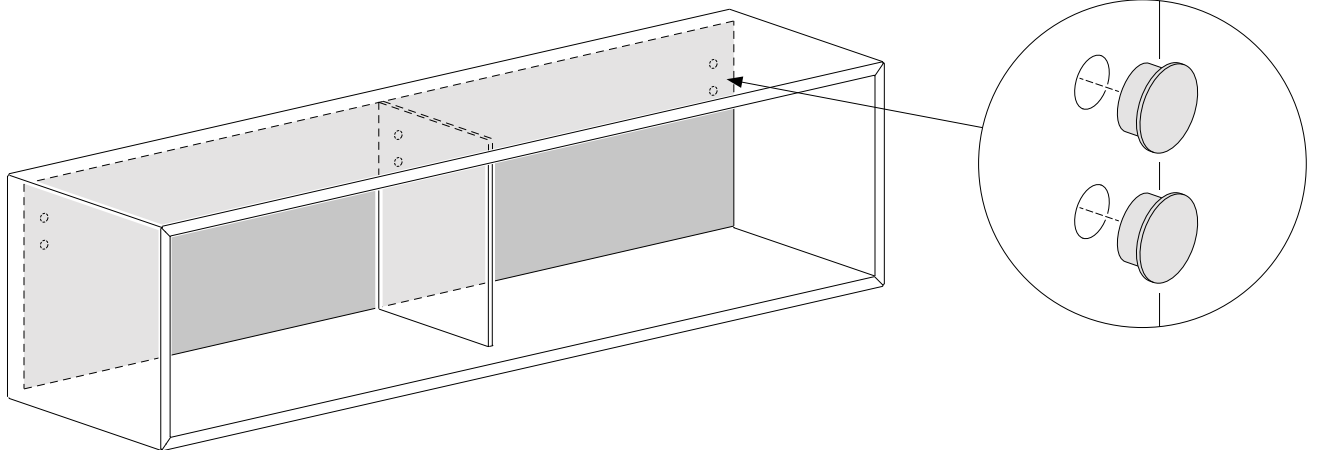

**Schienale in specchio, vetro lucido, vetro opaco o XGlass lucido o opaco (asportabile)  
Back in mirror, polished glass, matt glass, or polished or matt XGlass (removable)**

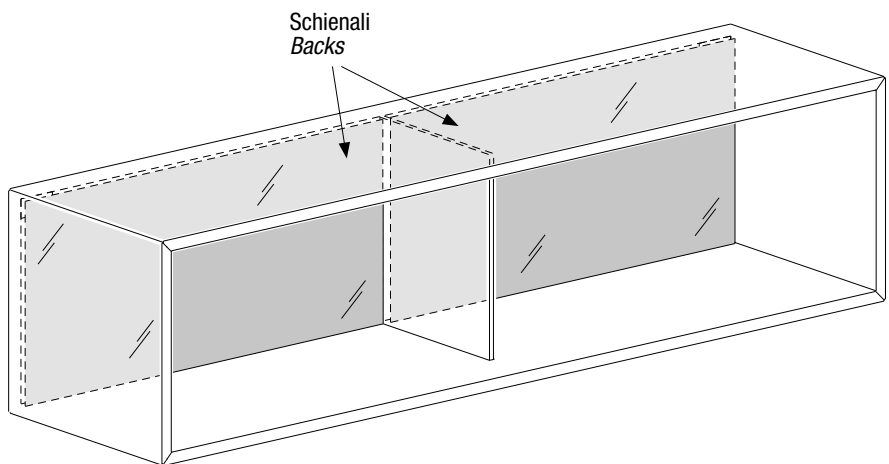

**Fissaggio//Fixing**

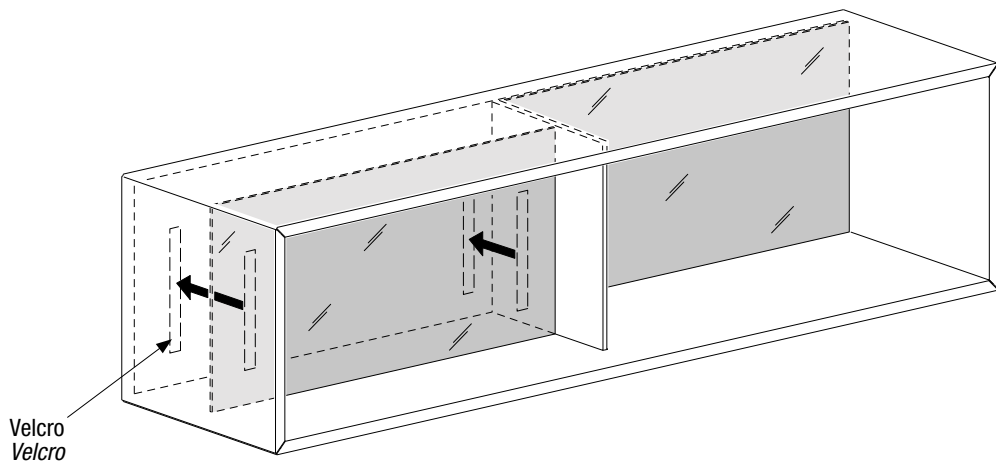

**Rimozione//Removal**

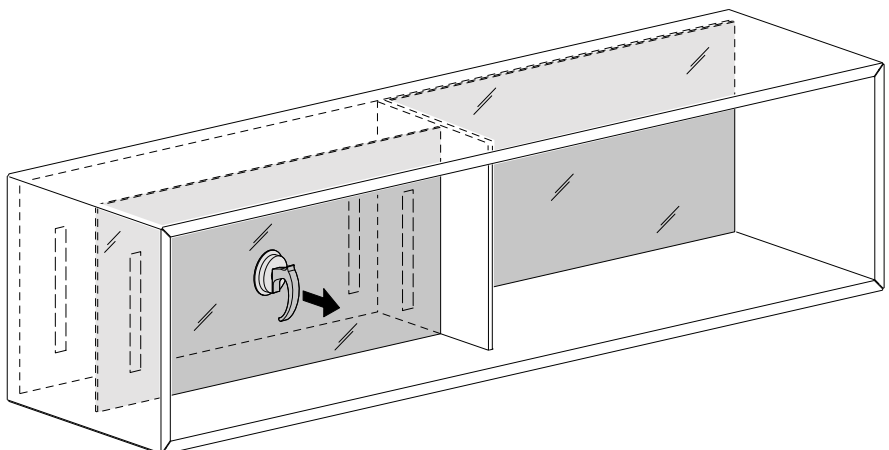



**Contenitori orizzontali//Horizontal storage units**

I contenitori di L 147,2 - 184 - 220,8 cm hanno un divisorio centrale in vetro trasparente, fumè grigio o fumè bronzo non asportabile.  
 È inserito in fresata tra il fondo e il coperchio del contenitore.  
*Storage units W. 147,2 - 184 - 220,8 cm have a central partition in clear, smoked grey or smoked bronze glass which cannot be removed.  
 It is inserted in between the bottom and top of the storage unit.*

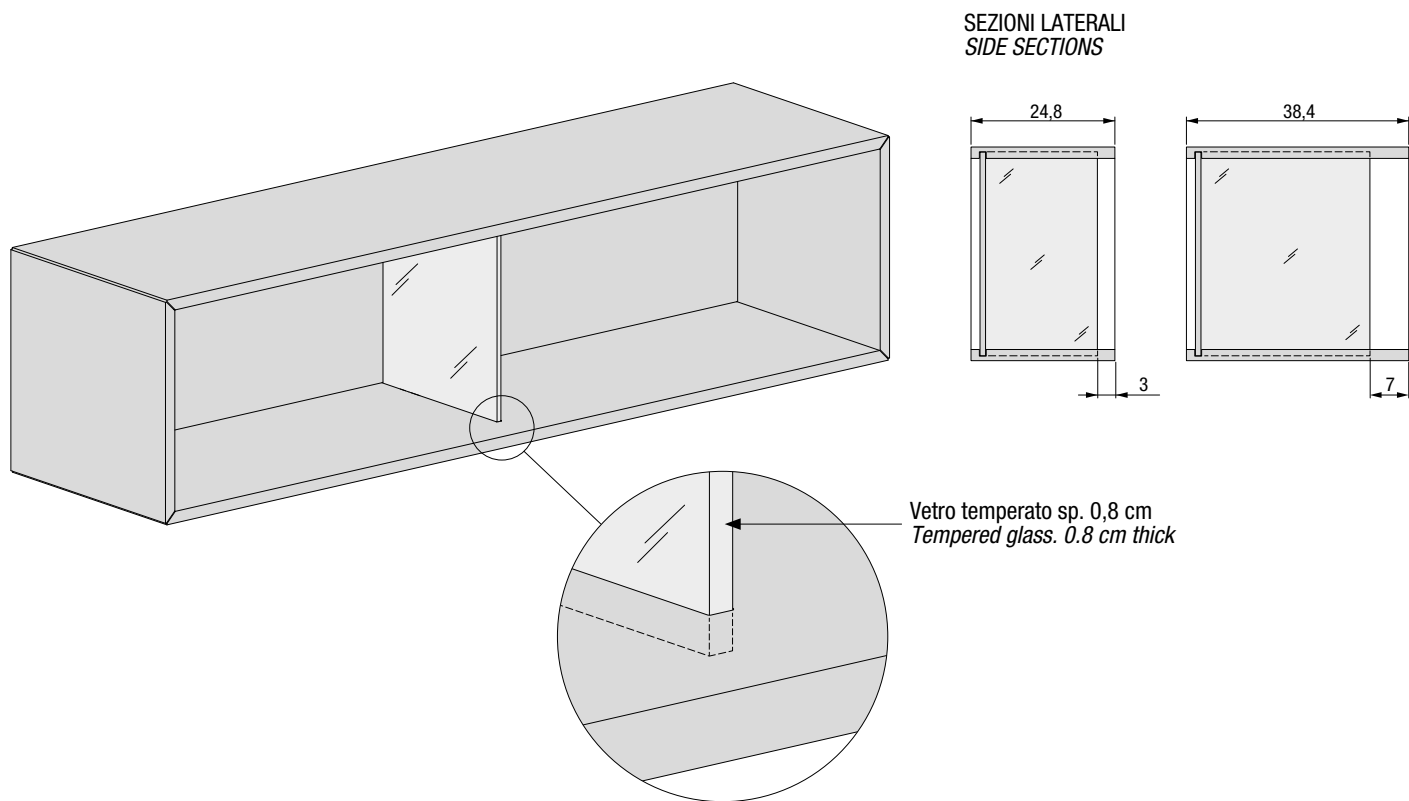

**Contenitori verticali//Vertical storage units**

Tutti i ripiani sono in vetro trasparente, fumè grigio o fumè bronzo e non sono asportabili.  
 Vengono inseriti in fresata tra i fianchi del contenitore.  
*All shelves are in clear, smoked grey or smoked bronze glass and cannot be removed.  
 They are inserted in between the sides of the storage unit.*

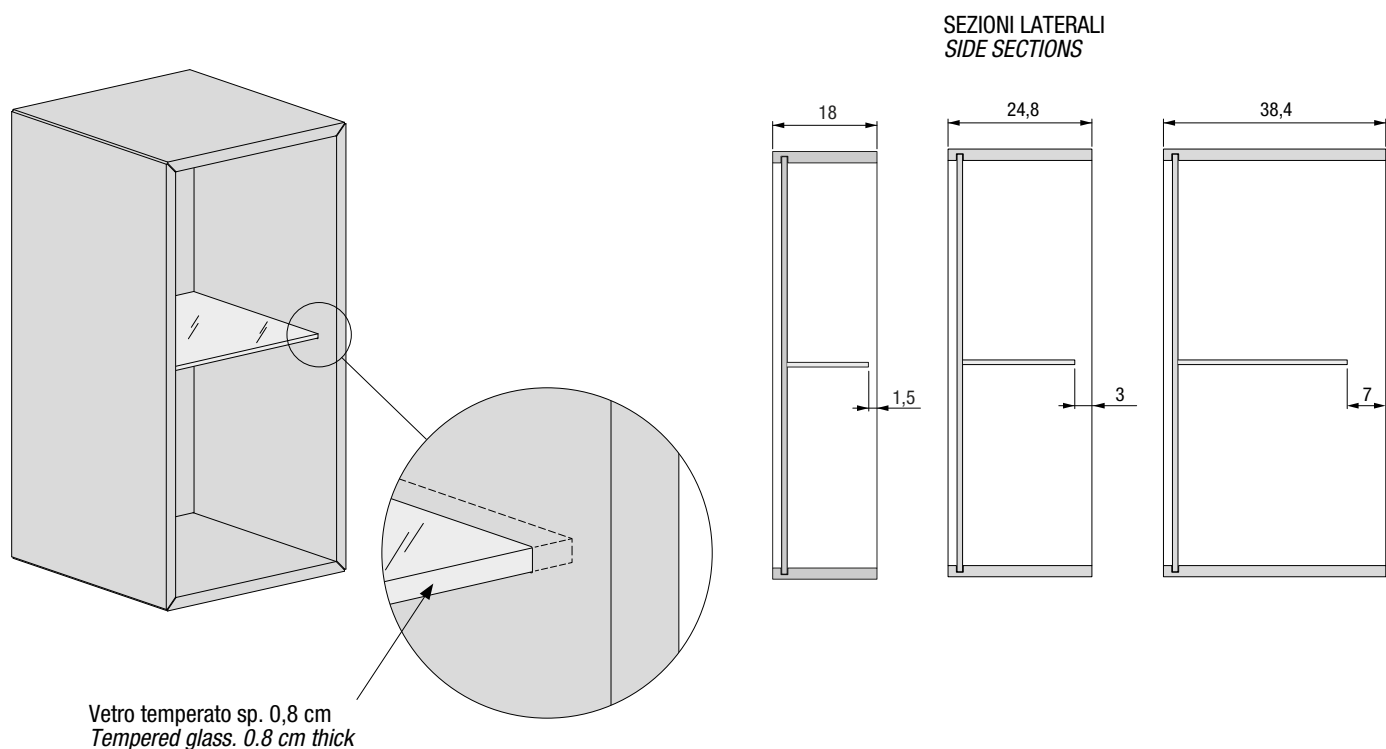

## 36e8 GLASS\_STORAGE

Contenitori a giorno in vetro.  
*Glass open-fronted storage units.*

### Contenitore chiuso 4 lati *Storage unit closed on 4 sides*

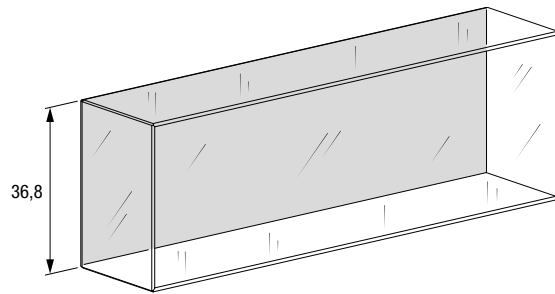

### Contenitore senza 1 angolo 18,4 x 18,4 *Storage unit without 1 corner 18,4 x 18,4*

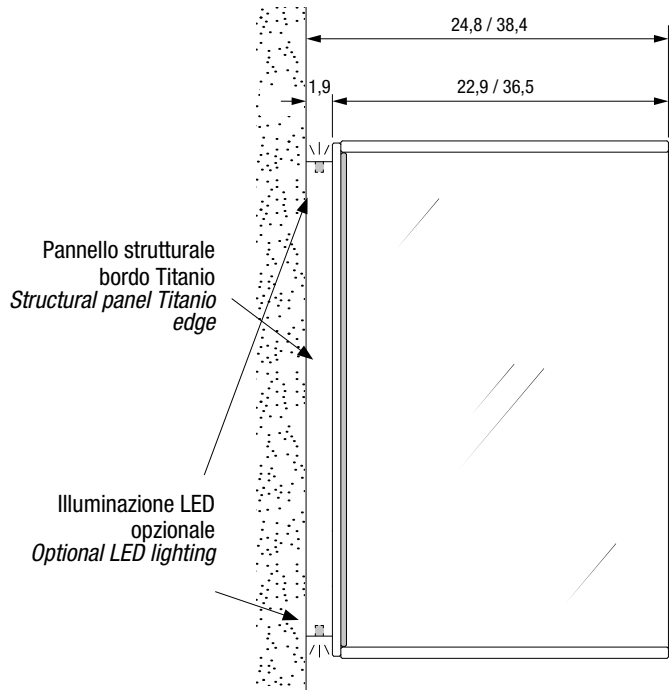
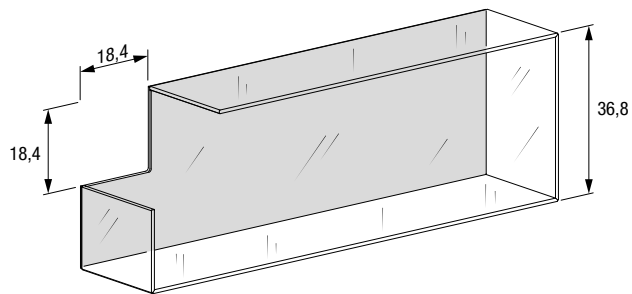

### Componibilità *Modularity*

Da utilizzare sempre affiancato ad un contenitore in legno o vetro (o al 30mm-LagoLinea)  
*To be used in combination with a storage unit in wood or glass (or the 30mm-LagoLinea)*

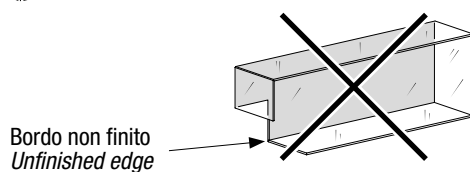
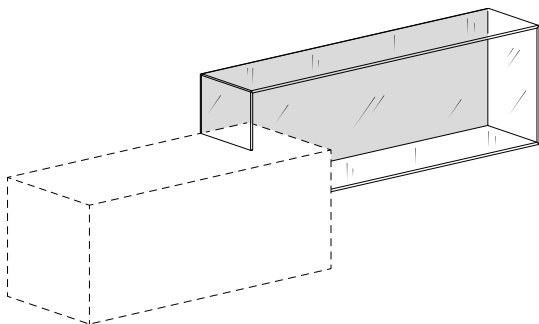
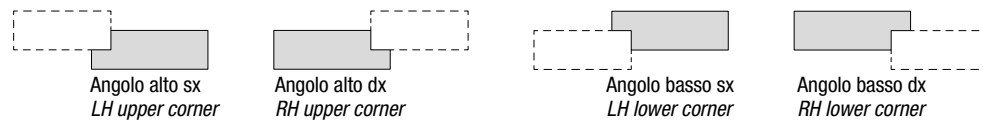

## 36e8 SIDE\_STORAGE

È possibile richiedere che il contenitore abbia un lato laccato in un colore diverso o abbia una finitura diversa rispetto al resto della scocca.  
*Storage units can be requested with one side lacquered in a different colour or in a different finish to the rest of the bodywork.*

**Esempi:**  
**Examples:**

**CON ANTA**  
**WITH DOOR**

**FIANCO SX**  
**LEFT SIDE**

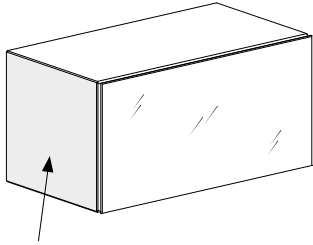

Laccato o Rovere Gentle  
*Lacquered or Gentle oak*

**FIANCO DX**  
**RIGHT SIDE**

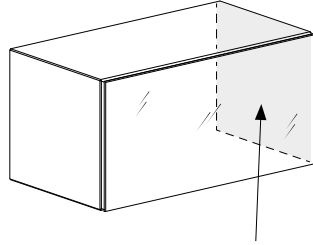

Laccato o Rovere Gentle  
*Lacquered or Gentle oak*

**TOP**  
**TOP**

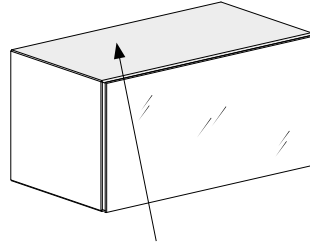

Laccato o Rovere Gentle  
*Lacquered or Gentle oak*

**FONDO**  
**BASE**

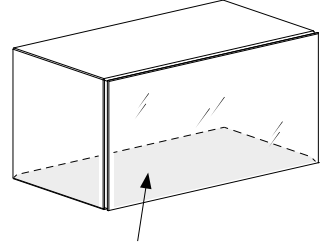

Laccato o Rovere Gentle  
*Lacquered or Gentle oak*

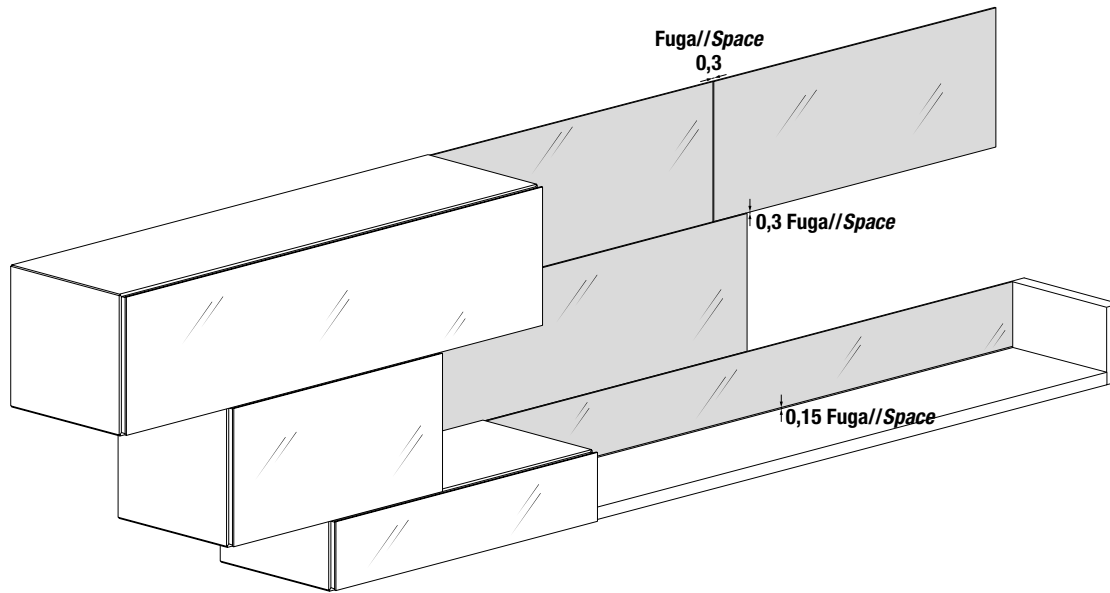

**H 18,4 (H reale 18,1)**  
H 18,4 (Real H 18,1)

**Cassetto 36e8**  
36e8 drawer



**H 18,4 (H reale 15,1)**  
H 18,4 (Real H 15,1)

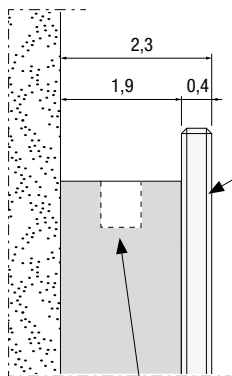
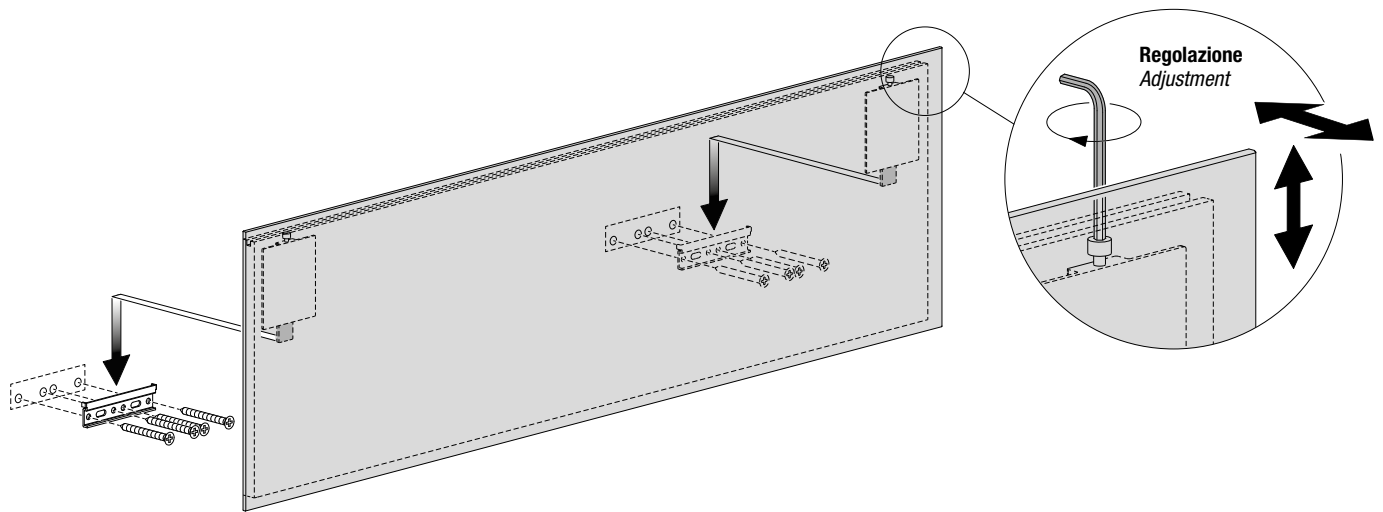

**Vetro, XGlass, Specchio**  
Glass, XGlass, Mirror

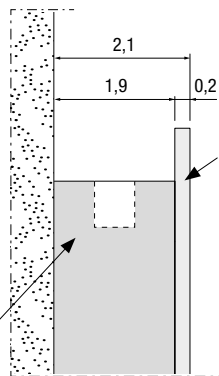

**Metallo**  
Metal

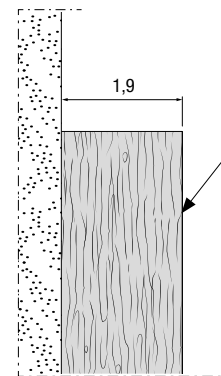

**Rovere Gentile**  
Gentle Oak

illuminazione LED opzionale  
Optional LED lighting

Non è possibile applicare l'illuminazione LED ai 36e8 Wall Panel nella finitura Rovere Gentile.  
LED lighting cannot be applied to 36e8 Wall Panels in the Gentle oak finish.

# Laccato

EN Lacquered / ES Lacado / FR Laqué / DE Lackiert

Solidità, rigore, rassicurante perfezione formale e accessibilità: il laccato è una tavolozza creativa in cui funzionalità e colori realizzano la superficie visiva del design. La laccatura è realizzata con prodotti all'acqua privi di solventi evitando così l'emissione di sostanze organiche volatili nocive nell'ambiente.

Solidity, rigour, reassuring formal perfection and accessibility: lacquer is a creative palette where functionality and colour create visual surfaces with a design sensibility. LAGO lacquer is made with solvent-free, water-based products, thus avoiding the emission of noxious, volatile organic substances in the environment.

Solidez, rigor, tranquilizadora perfección formal y accesibilidad: el lacado es una paleta creativa en donde la funcionalidad y los colores hacen realidad la superficie visual del diseño. El proceso de lacado se realiza con productos acuosos que no contienen solventes, evitando así la emisión al medio ambiente de sustancias orgánicas volátiles nocivas.

Solidité, rigueur, rassurante perfection formelle et accessibilité: le laqué est une palette créative dans laquelle fonctionnalités et couleurs créent la surface visuelle du design. La finition laquée est réalisée avec des produits hydriques sans solvants qui évitent l'émission de composés organiques volatils nocifs pour l'environnement.

Haltbarkeit, Geradlinigkeit, formelle beruhigende Perfektion: Die Farblacke sind Teil einer kreativen Farbpalette, in der Funktionalität und Farben die visuelle Oberfläche des Designs verwirklichen. Der Lackanstrich wird mit Produkten durchgeführt, die Wasser enthalten und lösungsmittelfrei sind, um so das Entweichen von schädlichen, organischen Stoffen in die Umwelt zu vermeiden.



La rappresentazione dei colori ha valore indicativo / The colour representation is indicative / La representación de los colores tiene valor indicativo / La représentation des couleurs est indicative / Die abgebildeten Farben können vom Original abweichen.

# Vetro lucido

EN Polished glass / ES Cristal brillante / FR Verre brillant / DE Glas poliert

Il vetro LAGO cattura lo sguardo con una nuova esperienza del colore, reso vivo, profondo e mutevole al variare delle condizioni della luce. Rigorosamente perfetto, mantiene inalterata attraverso il tempo la propria bellezza. Il vetro ha doti intrinseche di igienicità, facile da pulire in quanto non assorbe lo sporco e le macchie e temperato, ovvero trattato termicamente per ottenere una elevata resistenza all'urto, al graffio e al calore. Viene verniciato all'acqua ed è un materiale riciclabile al 100%.

LAGO glass captures the eye with a new experience of colour, made brilliant, deep and changeable according to light conditions. Rigorously perfect, it preserves its beauty unaltered over time. LAGO glass has intrinsic hygienic properties, it is easy to clean since it does not absorb dirt or stains and it is tempered, that is to say temperature-treated in order to obtain higher resistance to shocks, scratches and heat. It is painted with water-based colour and is a 100% recyclable material.

El vidrio LAGO cautiva la mirada con una nueva forma de vivir el color, vuelto vivo, profundo y cambiante al variar las condiciones de luz. Rigorosamente perfecto, mantiene inalterada en el tiempo su belleza. El vidrio tiene características intrínsecas que lo hacen un material limpio: es fácil de lavar ya que no absorbe la suciedad ni las manchas, y con el templado es tratado térmicamente para obtener una alta resistencia a los golpes, las ralladuras y el calor. Está barnizado al agua y es un material 100% reciclable.

Le verre LAGO accroche le regard avec une nouvelle expérience de la couleur, rendue vive, profonde et changeante en fonction des variations lumineuses. Rigoureusement parfait, il conserve une beauté inaltérée à travers le temps. Le verre a des qualités hygiéniques intrinsèques: il est facile à nettoyer, car il n'absorbe ni la saleté ni les taches, et est trempé, c'est-à-dire traité thermiquement pour renforcer sa résistance aux chocs, aux rayures et à la chaleur. Verni à l'eau, ce matériau est 100 % recyclable.

Das LAGO-Glas lenkt den Blick mit einem neuen Farberlebnis auf sich, das sich Stunde um Stunde mit den Verhältnissen des Lichts als lebendig, tiefgründig und veränderbar erweist. Auf perfekte Art und Weise behält es strengstens seine Schönheit, die sich im Laufe der Zeit kein bisschen verändert. Das Glas verfügt über die einmalige Gabe der Reinheit. Es ist leicht zu reinigen, da es keinen Schmutz und keine Flecken aufnimmt; es ist für eine höhere Resistenz Stößen, Kratzern und Hitze gegenüber temperiert bzw. wärmebehandelt. Es wird mit Farben auf Wasserbasis gestrichen und ist ein 100%ig recyclefähiges Material.



La rappresentazione dei colori ha valore indicativo / The colour representation is indicative / La representación de los colores tiene valor indicativo / La représentation des couleurs est indicative / Die abgebildeten Farben können vom Original abweichen.

# Vetro opaco

EN Matt glass / ES Cristal mate / FR Verre mat / DE Glas satiniert

Grazie a un processo di acidatura delle lastre, il vetro opaco LAGO crea nuovi linguaggi compositivi mescolando la perfezione tattile e formale di questo materiale con un effetto visivo sorprendente. Più delicato del vetro lucido ha doti di igienicità ed è temperato, ovvero trattato termicamente per ottenere una elevata resistenza all'urto, al graffio e al calore. Il vetro viene verniciato all'acqua ed è un materiale riciclabile al 100%.

Thanks to an acidizing process, LAGO opaque glass creates new compositional languages, mixing the tactile and formal perfection of this material with a surprising visual effect. More delicate than shiny glass, it has hygienic properties and is tempered, that is to say temperature-treated in order to obtain higher resistance to shocks, scratches and heat. LAGO opaque glass is painted with water-based colour and is a 100% recyclable material.

Gracias a un proceso de acidificación de las láminas, el vidrio opaco LAGO crea nuevos lenguajes compositivos mezclando la perfección táctil y formal de este material con un efecto visual sorprendente. Más delicado que el vidrio brillante, tiene cualidades higiénicas y está templado, es decir tratado térmicamente para obtener una alta resistencia a los golpes, las ralladuras y el calor. El vidrio está barnizado al agua y es un material 100% reciclable.

Grâce à un procédé de traitement à l'acide des plaques, le verre opaque LAGO crée de nouveaux langages de composition, en mêlant la perfection tactile et formelle de ce matériau avec un effet visuel saisissant. Plus délicat que le verre poli, il est hygiénique et trempé, c'est-à-dire traité thermiquement pour une meilleure résistance au chocs, aux rayures et à la chaleur. Ce verre verni à l'eau est un matériau 100 % recyclable.

Dank einer Säurebehandlung der Scheiben, erfindet das Mattglas von LAGO eine neue Kompositionssprache, indem es die tastbare und formale Perfektion dieses Materials mit einem offensichtlichen, erstaunlichen Effekt vereint. Es ist delikater als transparentes Glas und verfügt über hygienische Eigenschaften; ist für eine höhere Resistenz Stößen, Kratzern und Hitze gegenüber temperiert bzw. wärmebehandelt. Es wird mit Farben auf Wasserbasis gestrichen und ist ein 100%ig recyclefähiges Material.



La rappresentazione dei colori ha valore indicativo / The colour representation is indicative / La representación de los colores tiene valor indicativo / La représentation des couleurs est indicative / Die abgebildeten Farben können vom Original abweichen.

# Vetro Metal lucido e opaco

<sup>EN</sup> Polished and matt Metal Glass / <sup>ES</sup> Cristal Metal brillante es mate / <sup>FR</sup> Verre Métal brillant et mat / <sup>DE</sup> Glas Metal poliert und satiniert

Tre colorazioni dai riflessi metallici caldi e cangianti avvolgono le superfici in modo uniforme, donando dinamismo e luminosità al prodotto nelle diverse finiture, lucida e opaca. Colori vivi che producono eleganti effetti visivi al variare della luce naturale e domestica. Realizzati con prodotti all'acqua privi di solventi, garantiscono igienicità e resistenza nel tempo grazie alle proprietà intrinseche del vetro.

Three shimmering metallic colours dominate the surface evenly, creating a bright, warm and dynamic look, available in a range of matt and polished finishes. Vivid colours create elegant visuals as the light changes both indoors and outdoors. Produced using solvent-free, water-based products, your furniture is hygienic and durable over time, thanks to the intrinsic qualities of glass.

Tres coloraciones de reflejos metálicos cálidos y cambiantes envuelven las superficies de manera uniforme, dando dinamismo y luminosidad al producto en los diferentes acabados brillo y mate. Colores vivos que producen elegantes efectos visuales al variar la luz natural y doméstica. Realizados con productos al agua sin disolventes, garantizan higiene y resistencia a lo largo del tiempo gracias a las propiedades intrínsecas del cristal.

Trois coloris aux reflets métalliques chauds et chatoyants enveloppent les surfaces de manière uniforme, tout en donnant dynamisme et luminosité au produit dans les différentes finitions, brillantes et mates. Des couleurs vives qui produisent d'élégants effets visuels selon la variation de la lumière naturelle et domestique. Réalisés avec des produits à l'eau sans solvants, ils garantissent hygiène et résistance dans le temps grâce aux propriétés intrinsèques du verre.

Drei Farben mit warmen, changierenden Metallic-Reflexen umhüllen die Oberflächen gleichmäßig und verleihen dem Produkt in den verschiedenen Ausführungen – glänzend und matt – Dynamik und Helligkeit. Lebendige Farben, die bei wechselndem natürlichem und häuslichem Licht elegante visuelle Effekte erzeugen. Sie werden mit lösungsmittelfreien Produkten auf Wasserbasis hergestellt und garantieren dank der charakteristischen Eigenschaften von Glas Hygiene und Haltbarkeit.

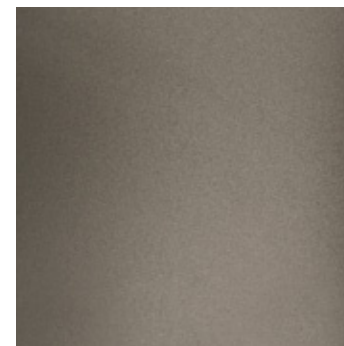

CHAMPAGNE METAL

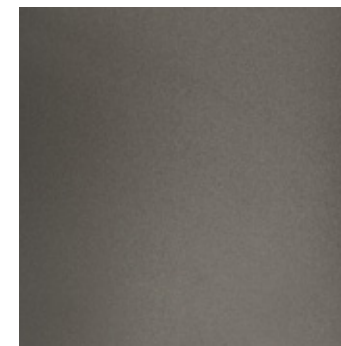

PIOMBO METAL

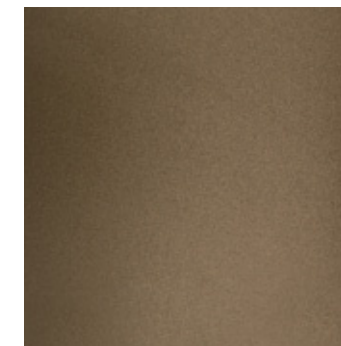

TUNDRA METAL



# XGlass lucido e opaco

EN Polished and matt XGlass / ES XGlass brillante es mate / FR XGlass brillant et mat / DE XGlass poliert und satiniert

La rivoluzione tecnologica sta accelerando i processi di innovazione anche nel campo dei materiali, offrendo opportunità incredibili. Grazie alla digital print XGlass coniuga le qualità di un materiale nobile e prezioso come il vetro alle emozioni di molteplici materiali. Le diverse finiture, lucida e opaca, aumentano poi l'empatia con il materiale stesso. Una raffinata continuità di pattern connota le superfici dei prodotti. XGlass è una strategia innovativa anche per poter ridurre in più casi l'impatto ambientale e migliorare quello sociale.

The technological revolution is speeding up innovation and offering incredible opportunities, including in the field of materials. Using digital printing technology, XGlass combines the fine qualities of glass with the emotion of a whole range of other materials. The different finishes, available in glossy and mat, increase empathy with the material itself and a refined continuous pattern defines the surface of each piece. XGlass is also an innovative solution for reducing environmental impact in many cases and improving the social one.

La révolution technologique accélère les processus d'innovation même dans le domaine des matériaux et ouvre la voie à d'incroyables opportunités. Grâce à l'impression numérique, XGlass combine les qualités d'un matériau noble et précieux comme le verre aux émotions de plusieurs matériaux. Les diverses finitions, brillante et opaque, intensifient l'empathie avec le matériau lui-même. Cette continuité raffinée de motifs caractérise les surfaces des produits. XGlass est également une stratégie innovante qui permet de réduire, dans de nombreux cas, l'incidence environnementale et d'améliorer l'impact social.

La revolución tecnológica está acelerando los procesos de innovación en el campo de los materiales, ofreciendo oportunidades increíbles. Gracias a la impresión digital, XGlass conjuga las cualidades de un material noble y preciado como el cristal con las emociones de múltiples materiales. Los diferentes acabados, brillo y mate, aumentan también la empatía con el material mismo. Una elegante continuidad de estampados distinguen las superficies de los productos. XGlass es una estrategia innovadora también para poder reducir en más casos el impacto ambiental y mejorar el social.

Die technologische Revolution beschleunigt Innovationsprozesse auch im Bereich der Materialien und bietet unglaubliche Möglichkeiten. Dank des Digitaldrucks verbindet XGlass die Eigenschaften eines edlen und kostbaren Materials wie Glas mit den Emotionen vieler Materialien. Die verschiedenen Ausführungen, die glänzend und matt erhältlich sind, sorgen für noch mehr Begeisterung. Ein raffinierter Übergang der Muster auf der Oberflächen gibt den Produkte ihren besonderen Charakter. XGlass ist ein innovative Instrument zur Verringerung der Umweltbelastung und zur Verbesserung der sozialen Auswirkungen.

## MARBLE XGLASS

Gamma completa - Complete range - Amplia gama - Gamme complète - Umfassende Palette

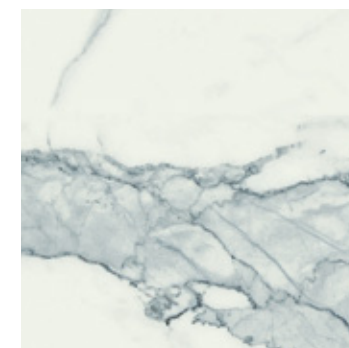

STATUARIO



PAONAZZO



CALACATTA GOLD



ONICE GRIGIO

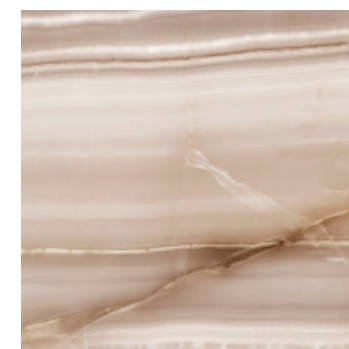

ONICE

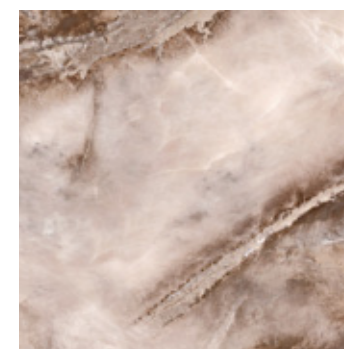

ALABASTRO

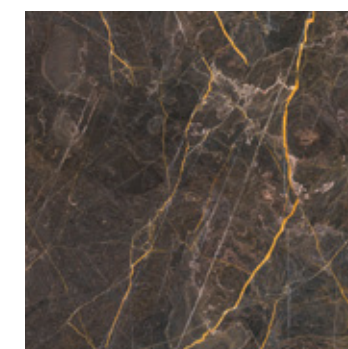

PORT SAINT LAURENT

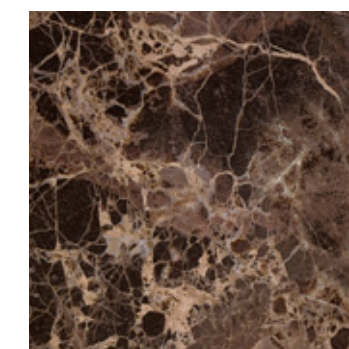

EMPERADOR

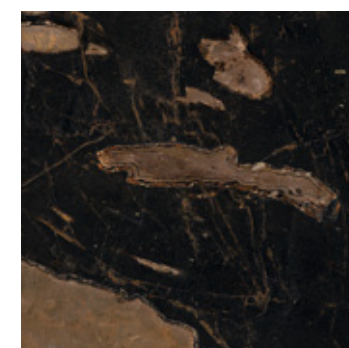

GEODE

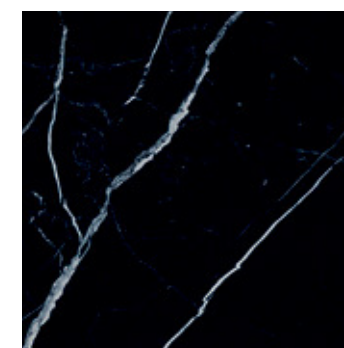

MARQUINA

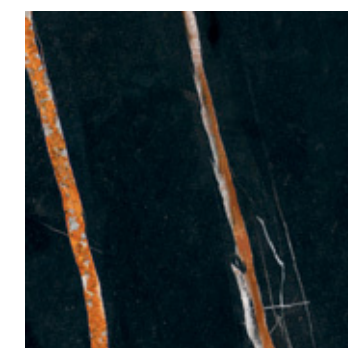

SAHARA NOIR

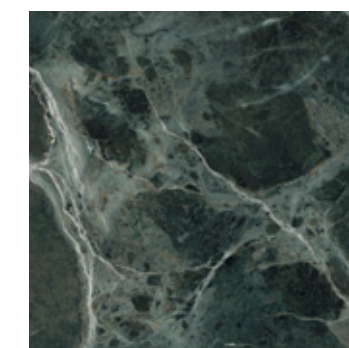

VERDE ALPI

**MARBLE XGLASS**

Scala 1:3 - Scale 1:3 - Escala 1:3 - Échelle 1:3 - Maßstab 1:3

3 m

2 m

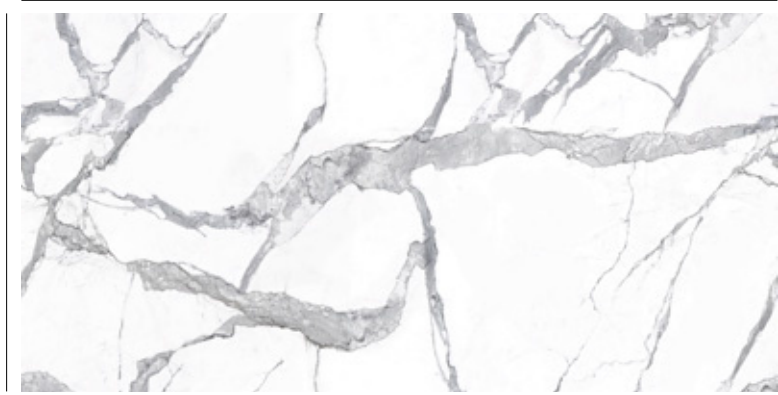

STATUARIO



PAONAZZO



CALACATTA GOLD



ONICE GRIGIO

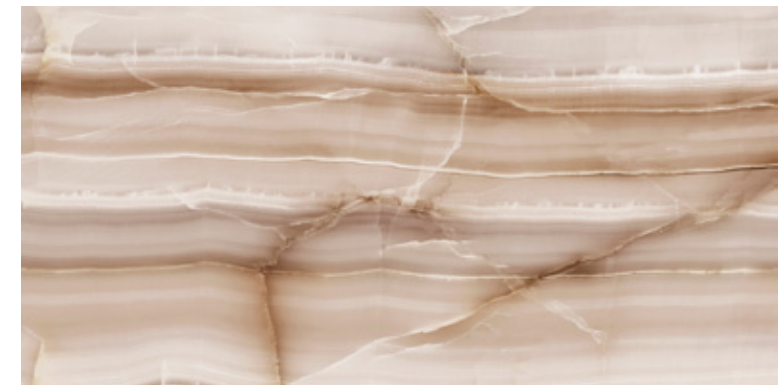

ONICE



ALABASTRO

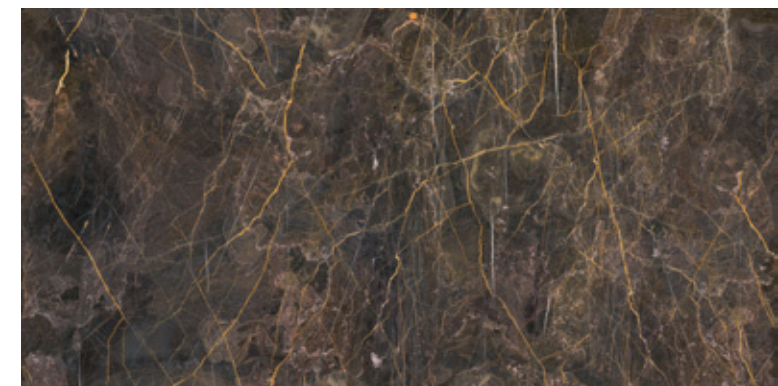

PORT SAINT LAURENT



EMPERADOR

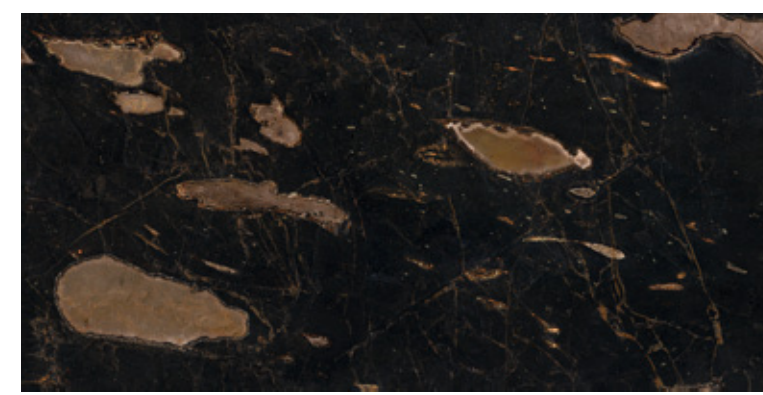

GEODE



MARQUINA

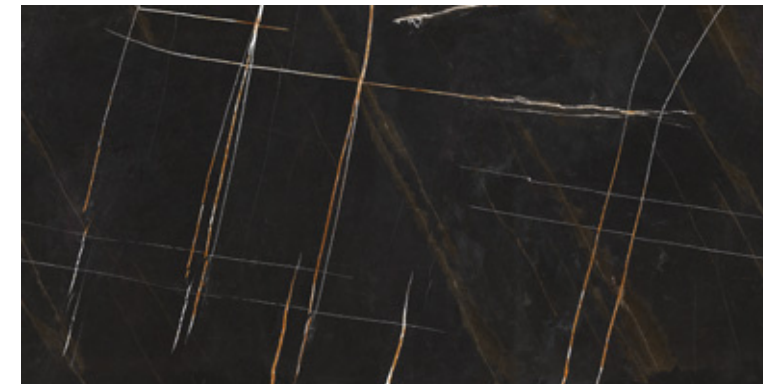

SAHARA NOIR

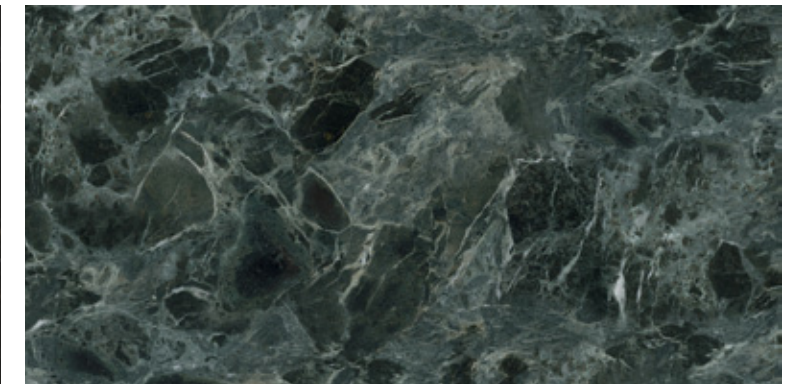

VERDE ALPI

## METAL XGLASS



TITANIO

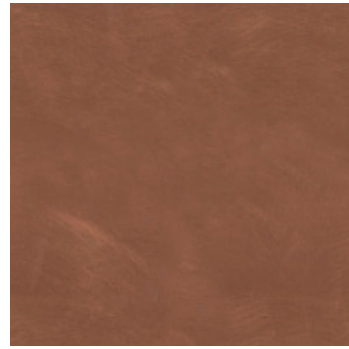

RAME



ORO



BRONZO



PELTRO

## HOME COUTURE XGLASS

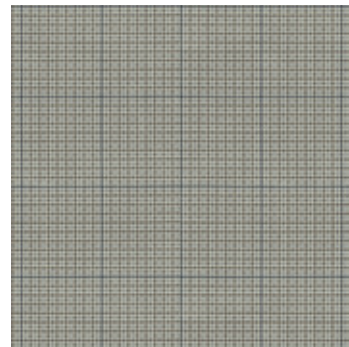

KISS WOOL

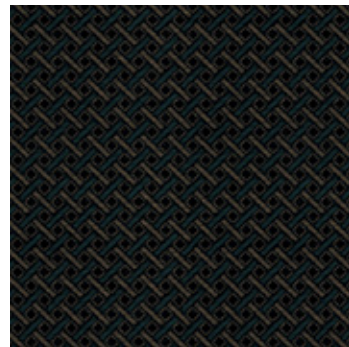

POP PANTS

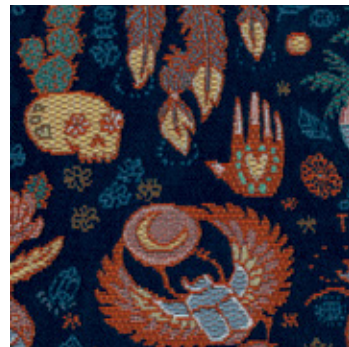

ART & CRAFT

## ANIMAL ZERO XGLASS\*

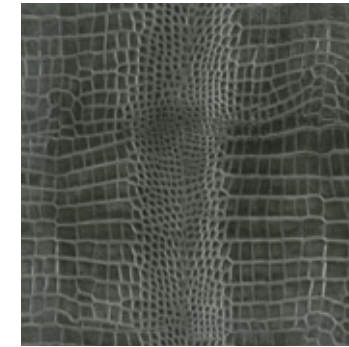

COCCODRILLO VERDE

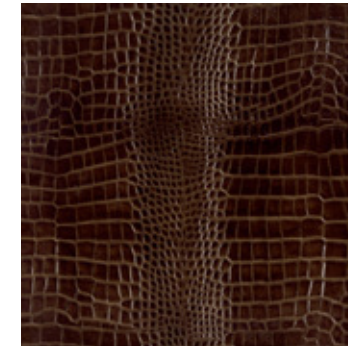

COCCODRILLO MARRONE

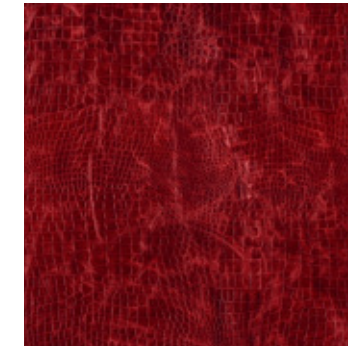

COBRA ROSSO



PITONE

*\*Disponibile solo nella versione lucida. / Available only in the polished version. / Disponible sólo en la versión brillante. / Disponible uniquement en version brillant. / Nur in der poliert Version erhältlich.*

## WOOD XGLASS

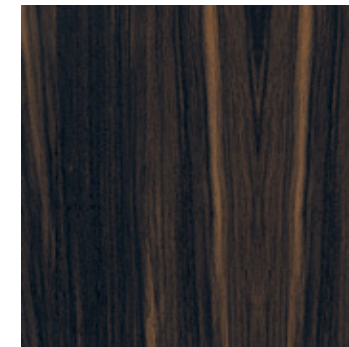

EBANO MACASSAR

# Aqua

L'eleganza intrinseca del vetro opaco combinata alla sua raffinata lavorazione tridimensionale, dà vita a un materiale dalla piacevole sensazione tattile. Grazie a questa particolare tecnica decorativa del vetro, le luci trasformano le superfici, modificando anche la percezione visiva delle finiture, che spaziano dal laccato all'XGlass.

Intrinsically elegant matt glass combined with a sophisticated three-dimensional processing technique creates a pleasantly tactile material. With this special glass decoration technique, the surfaces transform in the light, altering the look of the finishes ranging from lacquer to XGlass.

L'élégance intrinsèque du verre mat, alliée à son usinage raffiné en trois dimensions, donne vie à un matériau offrant une agréable sensation tactile. Grâce à cette technique spécifique de décoration du verre, les lumières transforment les surfaces et modifient également la perception visuelle des finitions qui vont du laqué au XGlass.

La elegancia intrínseca del cristal mate combinada con su refinada elaboración tridimensional da vida a un material de agradable sensación táctil. Gracias a esta singular técnica decorativa del cristal las luces transforman las superficies, modificando también la percepción visual de los acabados, que van del lacado al XGlass.

Die inhärente Eleganz von opakem Glas schafft ein Material mit einer angenehmen Haptik. Dank dieser speziellen Glasdekorationstechnik verwandeln Lichter die Oberflächen und verändern auch die visuelle Wahrnehmung der Ausführungen, die von lackiert bis XGlass reichen.

## Aqua Vetro Opaco

Aqua Matt glass / Aqua Cristal mate / Aqua Verre mat / Aqua Glas satiniert

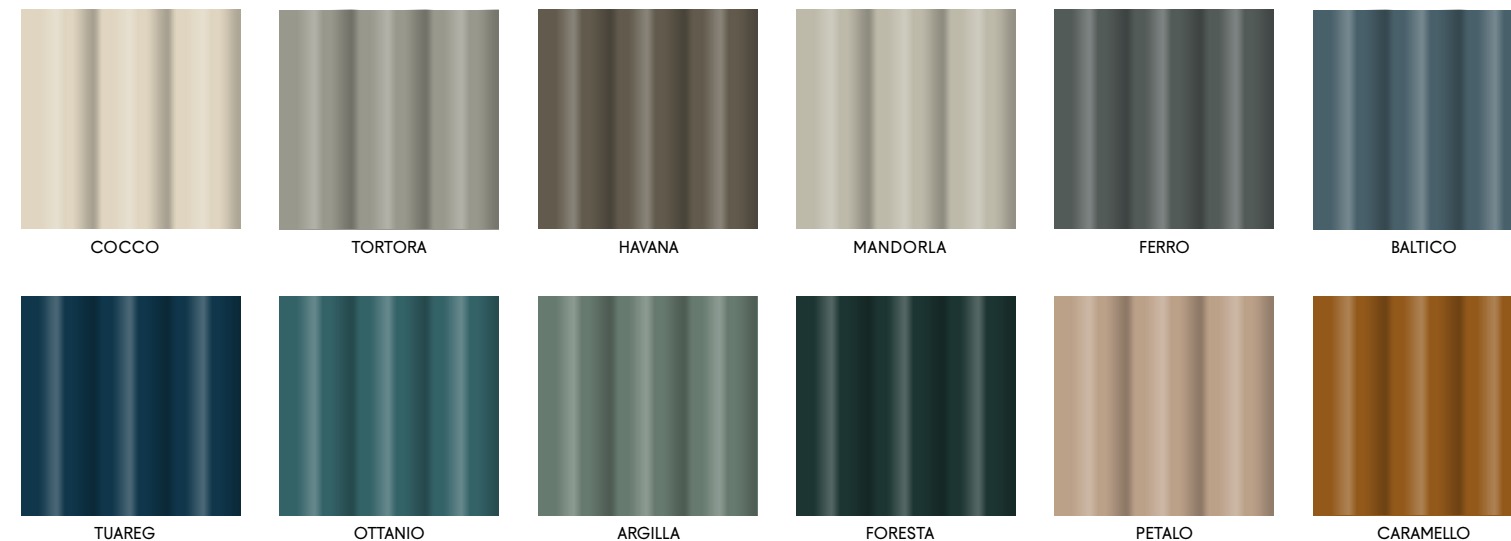

## Aqua XGlass opaco

Aqua matt XGlass / Aqua XGlass mate / Aqua XGlass mat / Aqua XGlass satiniert

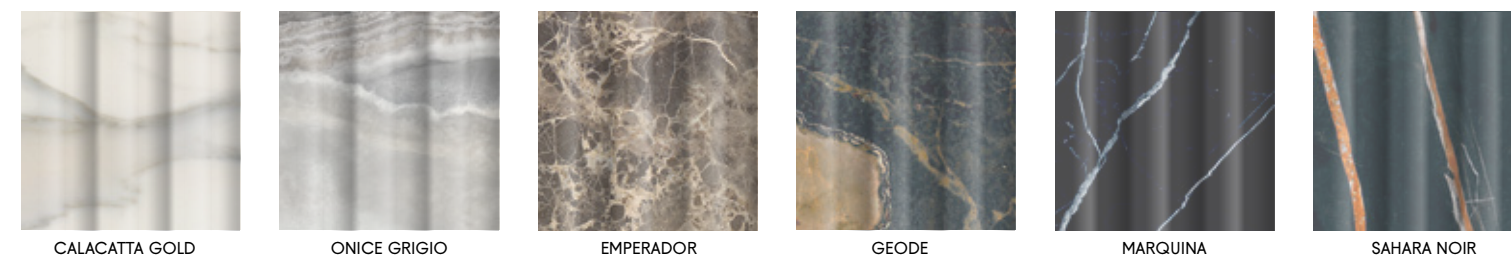

La rappresentazione dei colori ha valore indicativo / The colour representation is indicative / La representación de los colores tiene valor indicativo / La représentation des couleurs est indicative / Die abgebildeten Farben können vom Original abweichen.

# Wildwood

Calore, ospitalità, senso del tempo, il legno sa essere primordiale ambasciatore di verità e, allo stesso tempo, di un lusso raffinato e tattile. Realizzato a partire da legno di rovere piallato a mano, il Wildwood è sottoposto a una lavorazione artigianale che ne esalta le naturali imperfezioni. I nodi e le fessure sono stuccati con prodotti speciali ad alta resistenza e una verniciatura protettiva limita la permeabilità della superficie ai liquidi e alle macchie.

Warmth, hospitality, a sense of time: wood is a primordial ambassador of truth and, at the same time, a refined, tactile luxury. Made with hand-planed oak, is artisanally processed to enhance its natural imperfections. The knots and fissures are stuccoed with special highly resistant products and a protective varnish increases the water and stain resistance of the surfaces.

Calor, hospitalidad, sentido del tiempo; la madera sabe ser primordial embajadora de la verdad y, al mismo tiempo, de un lujo refinado y táctil. Realizada a partir de madera de roble cepillada a mano, la madera Wildwood es trabajada artesanalmente resaltando sus imperfecciones naturales. Los nudos y las hendiduras son enmasilladas con productos especiales de alta resistencia y un barnizado protector reduce la permeabilidad de la superficie a los líquidos y las manchas.

Chaleur, hospitalité, sens du temps, le bois sait être le principal ambassadeur de la vérité et, parallèlement, d'un luxe raffiné et tactile. Fabriqué à partir de bois de chêne raboté à la main, Wildwood est un bois travaillé artisanalement: ses imperfections naturelles sont donc exaltées. Les nœuds et les fissures sont stuqués avec des produits spéciaux à haute résistance et la perméabilité de sa surface aux liquides et aux taches est limitée par un vernis protecteur.

Wärme, Gastfreundlichkeit, Zeitgefühl. Holz kann wirklich als der Ur-Botschafter der Wahrheit angesehen und zugleich als ausgearbeiteter und tastbarer Luxus eingesetzt werden. Es entsteht aus Eichenholz, das per Hand gehobelt wird. Das Wildwood wird einer traditionellen Bearbeitung per Hand unterworfen, die die natürliche Unvollkommenheit dieses Holzes rühmt und hervorhebt. Die Baumknoten und -ritzen sind mit speziellen Produkten für eine hohe Festigkeit gekittet. Ein Schutzlack versiegelt die Oberfläche, wodurch diese für Flüssigkeiten und Flecken undurchlässig werden.



CHIARO



NATURALE



TABACCO

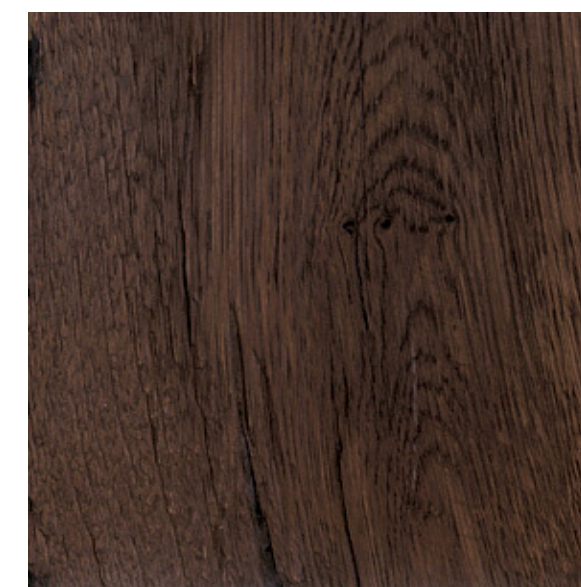

SCURO

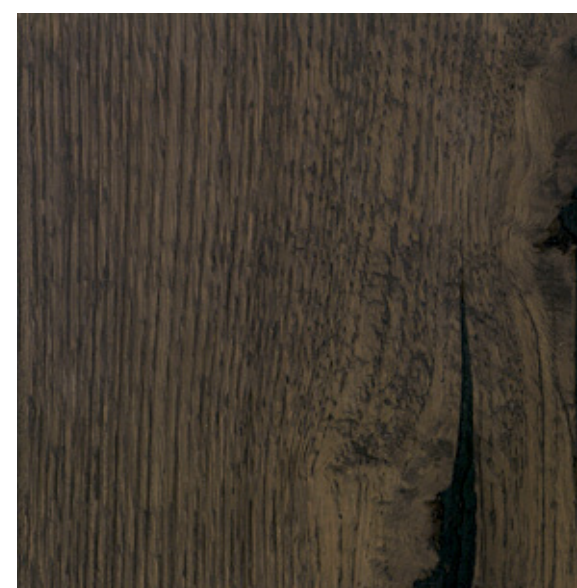

GRIGIO

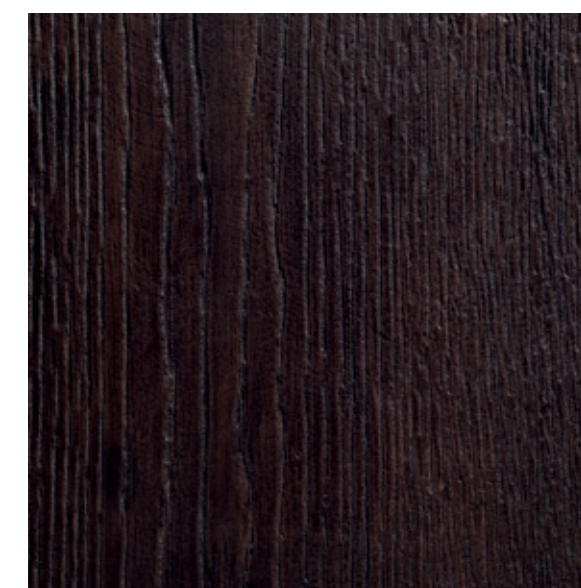

NERO